

***TM 10-8340-243-13&P**

**TECHNICAL MANUAL
OPERATOR'S, UNIT, AND DIRECT SUPPORT MAINTENANCE MANUAL,
INCLUDING REPAIR PARTS AND SPECIAL TOOLS LIST (RPSTL)
FOR
MODULAR COMMAND POST SYSTEM (MCPS), SMALL
TYPE I, GREEN, 5-4-6340-1
NSN: 8340-01-323-2454
TYPE I, TAN, 5-4-6340-2
NSN: 8340-01-334-7529
TYPE III, GREEN, 5-4-9690-1
NSN: 8340-01-528-4188
TYPE III, TAN, 5-4-9690-2
NSN: 8340-01-528-8210**



Type I



Type III

*TM 10-8340-243-13&P dated 1 April 2006 supercedes TM 10-5410-229-13&P dated 27 December 1991, including all changes.

DISTRIBUTION STATEMENT A. – Approved for public release; distribution is unlimited.

HEADQUARTERS, DEPARTMENT OF THE ARMY

30 APRIL 2006

WARNING SUMMARY

This warning summary contains general safety warnings and hazardous material warnings that must be understood and applied during operation of this equipment. Failure to observe these precautions could result in serious injury or death to personnel. Also included are explanations of the safety and hazardous materials icons used within this technical manual. For First Aid information refer to FM 4-25.11.



ELECTRICAL - electrical wire to arm with electricity symbol running through human body shows that shock hazard is present.



ENEMY HAZARD – missile impact to body shows that a precautions must be observed to prevent injury or death from enemy fire.



FIRE - flame shows that a material may ignite and cause burns.



HEAVY OBJECT - human figure stooping over heavy object shows physical injury potential from improper lifting technique.



HEAVY PARTS - heavy object on human figure shows that heavy parts present a danger to life or limb.



MOVING PARTS - hand with fingers caught between rollers shows that the moving parts of the equipment present a danger to life or limb.



SHARP OBJECT - pointed object in hand shows that a sharp object presents a danger to limb.



VAPOR - human figure in a cloud shows that material vapors present a danger to life or health.

WARNING

Refer to FM 4-25.11, FIRST AID, for First Aid information **BEFORE** proceeding with any task that is accompanied by a WARNING. Looking for first aid information after an injury can waste precious minutes and may mean the difference between life and death. Address first aid questions to trained medical personnel whenever possible.

GENERAL SAFETY WARNINGS DESCRIPTION

WARNING



DO NOT work with cables or lights unless the electrical power is disconnected from the power source. Possible fire or electrical hazard to personnel may occur. Lethal voltage is present when light sets are connected to a power source. Disconnect from power source before inspecting or repairing any electrical component. Ensure light set is properly grounded before applying power. Voltage is present when light set is connected to power source. Be careful not to contact electrical connections while performing tasks with power applied. Electrical shock and death may result from failure to heed this warning.

In the event of electrical shock, disconnect power from the source, administer Cardiopulmonary Resuscitation (CPR) if necessary, and seek immediate medical attention.

WARNING



KEEP ALL flammable objects away from tent to prevent fire damage and injury to personnel. Always use the spark arrestor provided with your heater when operating it inside the tent. Failure to do so can result in personal injury and damage to equipment.

In the event of fire, evacuate the MCPS and fight the fire from the outside. Seek immediate medical and firefighting assistance.

WARNING



MAKE SURE that all heater exhaust is vented to the outside. Carbon monoxide poisoning may result without proper venting. **CARBON MONOXIDE GAS CAN BE FATAL.** Carbon monoxide gas is not visible and has no smell, but it can be fatal. Breathing air with carbon monoxide produces symptoms of headache, dizziness, loss of muscular control, a sleepy feeling, and coma. Carbon monoxide occurs in exhaust fumes of fuel burning equipment such as internal combustion engines and heaters. Carbon monoxide can reach dangerous concentrations under conditions of no air movement. Failure to observe safety precautions may result in serious brain injury or death to personnel.

In the event of carbon monoxide poisoning, move the victim to a well ventilated area, administer Cardiopulmonary Resuscitation (CPR) if necessary, and seek immediate medical attention.

WARNING



The weight of the packed transport bags exceeds the recommended lifting limits for one person. Two persons should be used to lift bags to avoid personnel injury.

In the event of back injury, safely immobilize the victim and seek immediate medical attention.

WARNING



Failure to follow tie down and staking instructions may result in injury to personnel and damage to equipment. Stake the frame feet down with the steel tent pins. All of the frame feet must be staked down to avoid injury to personnel and damage to equipment. All tie downs must always be staked down. Failure to do so can result in personnel injury and damage to equipment.

In the event of back injury, safely immobilize the victim and seek immediate medical attention.

WARNING



Do not smoke or use seam sealer near open flame. Be sure to observe all warnings and instructions that come with the seam sealer. Use seam sealer in an open, well-ventilated area, away from sources of combustion. Avoid direct sunlight if possible. Failure to observe safety precautions may result in serious injury or death to personnel.

In the event of fire, evacuate the MCPS and fight the fire from the outside. Seek immediate medical and firefighting assistance.

In the event of vapor poisoning, remove the victim to a well ventilated area, administer Cardiopulmonary Resuscitation (CPR) if necessary, and seek immediate medical attention.

When handling the tent frame, do not grasp the frame near the frame joints. Failure to do so can result in personnel injury to hands and fingers.

In the event of amputation, contain bleeding, treat for shock, and seek immediate medical attention.

END OF WORK PACKAGE

LIST OF EFFECTIVE PAGES / WORK PACKAGES

NOTE: This manual supercedes TM 10-5410-229-13&P dated 27 December 1991. Zero in the "Change No." column indicates original page or work package.

Date of issue for revision is:

Original 30 April 2006

TOTAL NUMBER OF PAGES FOR FRONT AND REAR MATTER IS 30 AND TOTAL NUMBER OF WORK PACKAGES IS 50 CONSISTING OF THE FOLLOWING:

Page / WP No.	Change No.	Page / WP No.	Change No.
Title	0	WP 0022 (4 pgs)	0
a-d	0	WP 0023 (4 pgs)	0
i – viii	0	WP 0024 (4 pgs)	0
Chapter 1 Title Page	0	WP 0025 (4 pgs)	0
WP 0001 (4 pgs)	0	WP 0026 (4 pgs)	0
WP 0002 (22 pgs)	0	WP 0027 (4 pgs)	0
WP 0003 (6 pgs)	0	WP 0028 (4 pgs)	0
Chapter 2 Title Page	0	WP 0029 (4 pgs)	0
WP 0004 (2 pgs)	0	WP 0030 (4 pgs)	0
WP 0005 (34 pgs)	0	WP 0031 (4 pgs)	0
WP 0006 (4 pgs)	0	WP 0032 (4 pgs)	0
Chapter 3 Title Page	0	WP 0033 (4 pgs)	0
WP 0007 (2 pgs)	0	WP 0034 (4 pgs)	0
Chapter 4 Title Page	0	WP 0035 (4 pgs)	0
WP 0008 (6 pgs)	0	WP 0036 (4 pgs)	0
Chapter 5 Title Page	0	WP 0037 (4 pgs)	0
WP 0009 (2 pgs)	0	WP 0038 (4 pgs)	0
WP 0010 (8 pgs)	0	WP 0039 (4 pgs)	0
Chapter 6 Title Page	0	WP 0040 (2 pgs)	0
WP 0011 (2 pgs)	0	WP 0041 (4 pgs)	0
WP 0012 (8 pgs)	0	WP 0042 (2 pgs)	0
WP 0013 (4 pgs)	0	WP 0043 (2 pgs)	0
Chapter 7 Title Page	0	Chapter 10 Title Page	0
WP 0014 (6 pgs)	0	WP 0044 (2 pgs)	0
WP 0015 (4 pgs)	0	WP 0045 (4 pgs)	0
WP 0016 (2 pgs)	0	WP 0046 (4 pgs)	0
Chapter 8 Title Page	0	WP 0047 (10 pgs)	0
WP 0017 (2 pgs)	0	WP 0048 (2 pgs)	0
Chapter 9 Title Page	0	WP 0049 (2 pgs)	0
WP 0018 (6 pgs)	0	WP 0050 (2 pgs)	0
WP 0019 (6 pgs)	0	INDEX-1 – INDEX-8	0
WP 0020 (4 pgs)	0	Back Cover	0
WP 0021 (4 pgs)	0		

HEADQUARTERS
DEPARTMENT OF THE ARMY
WASHINGTON, D.C., 30 APRIL 2006

TECHNICAL MANUAL

OPERATOR'S, UNIT, AND DIRECT SUPPORT MAINTENANCE MANUAL, INCLUDING REPAIR PARTS AND SPECIAL TOOLS LIST (RPSTL)

For

MODULAR COMMAND POST SYSTEM (MCPS), SMALL

TYPE I, GREEN, 5-4-6340-1

NSN: 8340-01-323-2454

TYPE I, TAN, 5-4-6340-2

NSN: 8340-01-334-7529

TYPE III, GREEN, 5-4-9690-1

NSN: 8340-01-528-4188

TYPE III, TAN, 5-4-9690-2

NSN: 8340-01-528-8210

REPORTING ERRORS AND RECOMMENDING IMPROVEMENTS

You can help improve this manual. If you find any mistakes or if you know of a way to improve the procedures, please let us know. Mail your letter or DA Form 2028 (Recommended Changes to Publications and Blank Forms), located in the back of this manual directly to: Commander, U.S. Army Tank-automotive & Armament Command, ATTN: AMSTA-LC-CECT, Kansas St., Natick, MA 01760-5052. You may also send in your recommended changes via electronic mail or by fax. Our fax number is DSN 256-5205 or Commercial 508-233-5205. Our e-mail address is amssbriml@natick.army.mil. A reply will be furnished to you.

*TM 10-8340-243-13&P dated 1 April 2006 supercedes TM 10-5410-229-13&P dated 27 December 1991, including all changes.

DISTRIBUTION STATEMENT A. – Approved for public release; distribution is unlimited.

TABLE OF CONTENTS

	<u>WP Sequence No.</u>
	<u>Page No.</u>
Warning Summary	
How To Use This Manual	
Chapter 1 – General Information, Equipment Description, and Theory Of Operation	
General Information.....	WP 0001
Equipment Description and Data	WP 0002
Figure 1. Tent Frame Assembly.....	WP 0002-3
Figure 2. Plain Wall Assembly (Type I Shown).....	WP 0002-4
Figure 3. Window Wall Assembly (Type I Shown).....	WP 0002-5
Figure 4. Horizontal ECU/Window Wall Assembly.....	WP 0002-6
Figure 5. Entrance Way Assembly (Type I Shown).....	WP 0002-7
Figure 6. Roof Cap Assembly (Type I Shown).....	WP 0002-8
Figure 7. Rain Gutter Assembly.....	WP 0002-9
Figure 8. Floor Assembly (Type I Shown).....	WP 0002-10
Figure 9. Plain Wall Liner.....	WP 0002-11
Figure 10. Entrance Way/Window Wall Liner.....	WP 0002-12
Figure 11. ECU/Window Wall Insulated Liner.....	WP 0002-13
Figure 12. Entrance Way Insulated Liner	WP 0002-14
Figure 13. Boot Wall Assembly Insulated Liner.....	WP 0002-15
Figure 14. Roof Cap Assembly Insulated Liner.....	WP 0002-16
Figure 15. Rain Gutter Assembly Insulated Liner.....	WP 0002-17
Figure 16. Table and Mapboard.....	WP 0002-18
Figure 17. Light Set.....	WP 0002-19
Figure 18. Transport Bags and Tent Pin Container.....	WP 0002-20
Table 1. Equipment Data.....	WP 0002-22
Theory of Operation	WP 0003
Figure 1. Frame Assembly	WP 0003-1
Figure 2. Fabric Sections (Type I Shown).....	WP 0003-2
Figure 3. Light Assembly.....	WP 0003-3
Figure 4. Mapboard Assembly.....	WP 0003-4
Figure 5. Bootwalls	WP 0003-5
Figure 6. Complexing	WP 0003-6
Chapter 2 – Operator Instructions	
Description and Use of Operator Controls and Indicators	WP 0004
Figure 1. Frame Controls.....	WP 0004-1
Figure 2. Light Controls.....	WP 0004-2
Operation Under Usual Conditions	WP 0005
Figure 1. Modular Command Post System (MCPS), Small (Type I Shown)	
.....	WP 0005-1
Figure 2. Unpack the Three Frame Pieces	WP 0005-2
Figure 3. Assemble the Rafters.....	WP 0005-3
Figure 4. Connecting the Frame Sections.....	WP 0005-4
Figure 5. Install the Light Support Straps.....	WP 0005-5
Figure 6. Install the Roof Cap Liner.....	WP 0005-6
Figure 7. Secure the Roof Cap Liner.....	WP 0005-7
Figure 8. Roof Cap Installation.....	WP 0005-8
Figure 9. Unfolding the Frame Legs.....	WP 0005-9

	<u>Page No.</u>	<u>WP Sequence No.</u>
Operation Under Usual Conditions - Continued.....		WP 0005
Figure 10. Staking Tent lines.....	WP 0005-10	
Figure 11. Anchoring the Roof Cap.....	WP 0005-11	
Figure 12. Light Set Installation.....	WP 0005-12	
Figure 13. Extending the Frame to its Full Height.....	WP 0005-13	
Figure 14. Complexing the Tents.....	WP 0005-14	
Figure 15. Fabric Wall Assemblies Installation (Type I Shown)	WP 0005-15	
Figure 16. Wall Assembly Setup (Type I Shown).....	WP 0005-16	
Figure 17. Connecting Wall Sections (Type I Shown).....	WP 0005-17	
Figure 18. Entrance Way Set-Up.....	WP 0005-18	
Figure 19. Wall Liner Installation (Type I Shown).....	WP 0005-20	
Figure 20. Equipment Straps and Mapboard.....	WP 0005-21	
Figure 21. Folding Table.....	WP 0005-22	
Figure 22. Operation of Windows and Doors (Type I Shown)	WP 0005-23	
Figure 23. MCPS Setup Label on Frame Transport Bag.....	WP 0005-24	
Figure 24. Identification Labels.....	WP 0005-25	
Figure 25. Prepare Tables and Mapboards for Movement.....	WP 0005-26	
Figure 26. Disconnect Power from the Lights.....	WP 0005-27	
Figure 27. Prepare MCPS Fabric Sections for Movement (Type I Shown)	WP 0005-29	
Figure 28. Roof Cap Fabric.....	WP 0005-31	
Figure 29. Preparing Frame Sections for Movement.....	WP 0005-33	
Operation Under Unusual Conditions.....		WP 0006
Chapter 3 – Troubleshooting Master Index		
Troubleshooting Index.....		WP 0007
Chapter 4 – Troubleshooting Procedures		
Troubleshooting Procedures.....		WP 0008
Figure 1. Frame Assembly Troubleshooting.....	WP 0008-1	
Figure 2. Tent Leaking Troubleshooting (Type I Shown).....	WP 0008-2	
Figure 3. MCPS Will Not Stay Taut (Type I Shown).....	WP 0008-3	
Figure 4. Tent Lights Do Not Light.....	WP 0008-4	
Figure 5. Field Table Not Steady.....	WP 0008-5	
Chapter 5 – PMCS Maintenance Instructions		
Preventative Maintenance Checks and Services (PMCS) Introduction.....		WP 0009
Preventative Maintenance Checks and Services (PMCS).....		WP 0010
Table 1. Preventative Maintenance Checks and Services (PMCS)	WP 0010-1	
Figure 1. Frame Assembly PMCS.....	WP 0010-2	
Figure 2. Fabric Assemblies PMCS.....	WP 0010-4	
Figure 3. Table and Mapboard PMCS.....	WP 0010-5	
Figure 4. Light Set PMCS.....	WP 0010-7	
Figure 5. Transport Bags PMCS.....	WP 0010-8	

	<u>Page No.</u>	<u>WP Sequence No.</u>
Chapter 6 – Operator Maintenance Instructions		
Service Upon Receipt.....		WP 0011
Tent Fabric Assemblies.....		WP 0012
Figure 1. Repair Tent Fabric Assemblies with Adhesive Patch Application	WP 0012-3	
Figure 2. Repair Tent Fabric Assemblies with Hand Stitched Patch Application	WP 0012-4	
Figure 3. Hand Stitches.....	WP 0012-5	
Figure 4. Replace a Die-Inserted Grommet	WP 0012-6	
Figure 5. Repair Webbing and Buckles.....	WP 0012-7	
Light Set		WP 0013
Figure 1. Remove Light Assembly	WP 0013-1	
Figure 2. Replace Lamp	WP 0013-3	
Chapter 7 – Unit Maintenance Instructions		
Frame Assembly		WP 0014
Figure 1. Repair Handle, Rafter Assembly, Upper Leg Assembly, or Purlin....	WP 0014-3	
Figure 2. Replace Frame Lower Leg Assemblies	WP 0014-4	
Figure 3. Replace Detent Assembly.....	WP 0014-5	
Figure 4. Replace Cable Assemblies	WP 0014-6	
Mapboard Assembly.....		WP 0015
Figure 1. Repair Mapboard Assembly.....	WP 0015-2	
Illustrated List of Manufactured Items		WP 0016
Figure 1. Elastic Cord Fabrication	WP 0016-2	
Chapter 8 – Direct Support Maintenance Instructions		
Tent Fabric Assemblies.....		WP 0017
Figure 1. Type 301 Lock Stitch.....	WP 0017-2	
Figure 2. Type 401 Chain Stitch.....	WP 0017-2	
Chapter 9 – Parts Information		
Repair Parts and Special Tools Lists (RPSTL) Introduction		WP 0018
Group 01 Frame Assembly.....		WP 0019
Group 0201 Plain Wall Assembly		WP 0020
Group 0202 Window Wall Assembly		WP 0021
Group 0203 Horizontal ECU/Window Wall Assembly		WP 0022
Group 0204 Entrance Way Assembly		WP 0023
Group 0205 Roof Cap Assembly.....		WP 0024
Group 0206 Rain Gutter Assembly.....		WP 0025
Group 0207 Floor Assembly.....		WP 0026
Group 0208 Plain Wall Liner.....		WP 0027

	<u>Page No.</u>	<u>WP Sequence No.</u>
Group 0209 Entrance Way/Window Wall Liner		WP 0028
Group 0301 Insulated Liner, ECU / Window Wall		WP 0029
Group 0302 Insulated Liner, Entrance Way		WP 0030
Group 0303 Insulated Liner, Boot Wall Assembly		WP 0031
Group 0304 Insulated Liner, Roof Cap Assembly		WP 0032
Group 0305 Insulated Liner, Rain Gutter Assembly		WP 0033
Group 04 Table, Field, Folding Legs, Metal		WP 0034
Group 05 Complexing Map Board		WP 0035
Group 06 Light Assembly		WP 0036
Group 07 Transport Bag Assembly –Frame		WP 0037
Group 08 Transport Bag Assembly – Fabric		WP 0038
Group 09 Vestibule/Pin Container		WP 0039
Repair Parts For Special Tools		WP 0040
Group Bulk Material		WP 0041
National Stock Number Index		WP 0042
Part Number Index		WP 0043

Chapter 10 – Supporting Information

References		WP 0044
Maintenance Allocation Chart (MAC) Introduction		WP 0045
Maintenance Allocation Chart (MAC)		WP 0046
Table 1. MAC for Modular Command Post System	WP 0046-1	
Table 2. Tools and Test Equipment for Modular Command Post System	WP 0046-4	
Table 3. Remarks for Modular Command Post System	WP 0046-4	
Components Of End Item (COEI) and Basic Issue Items (BII) Lists		WP 0047
Table 1. Components Of End Item (COEI)	WP 0047-2	
Table 2. Basic Issue Items (BII)	WP 0047-9	
Additional Authorization List (AAL)		WP 0048
Table 1. Additional Authorization List (AAL)	WP 0048-2	
Expendable and Durable Items List		WP 0049
Table 1. Expendable and Durable Items List	WP 0049-2	
Mandatory Replacement Parts		WP 0050
Table 1. Mandatory Replacement Parts List	WP 0050-1	

ALPHABETICAL INDEX

HOW TO USE THIS MANUAL

In this manual, primary chapters appear in upper case/capital letter; work packages are presented in numeric sequence, e.g., 0001; paragraphs within a work package are not numbered and are presented in a titles format. For a first level paragraph, title all upper case/capital letters, e.g., FRONT MATTER subordinate paragraph title will have the first letter of the first word of each principle word all upper case/capital letters, e.g., Manual Organization and Page Numbering System. The location of additional material that must be referenced is clearly marked. Illustrations supporting maintenance procedures/text are located underneath, or as close as possible to, their referenced paragraph.

This manual contains General Information, Operator Instructions, Operator Preventive Maintenance Checks and Services (PMCS) for the Modular Command Post System (MCPS), Small.

Front Matter

Front matter consists of front cover, warning summary, title block, table of contents, and how to use this manual page.

Chapter 1 – General Information, Equipment Description, And Theory Of Operation

Chapter 1 contains introductory information on the Modular Command Post System (MCPS), Small and its associated equipment as well as a Theory of Operation.

Chapter 2 – Operator Instructions

Chapter 2 includes operating instructions under usual and unusual conditions.

Chapter 3 – Master Troubleshooting Index

Chapter 3 contains a master index to help locate specific troubleshooting procedures.

Chapter 4 – Troubleshooting Procedures

Chapter 4 contains operator-level troubleshooting.

Chapter 5 – PMCS Maintenance Instructions

Chapter 5 contains operator PMCS maintenance instructions.

Chapter 6 – Operator Maintenance Instructions

Chapter 6 contains operator maintenance instructions and service procedures.

Chapter 7 – Unit Maintenance Instructions

Chapter 7 contains service upon receipt, maintenance and service procedures authorized at the unit level.

Chapter 8 – Direct Support Maintenance Instructions

Chapter 8 contains maintenance instructions and service procedures authorized at the direct/general support level.

Chapter 9 – Parts Information

Chapter 9 contains information for ordering spare parts.

Chapter 10 – Supporting Information

Chapter 10 contains references and other supporting information.

Manual Organization and Page Numbering System

The manual is divided into eight major chapters that detail the topics mentioned above. Within each chapter are work packages covering a wide range of topics. Each work package is numbered sequentially starting at page 1. The work package has its own page numbering scheme and is independent of the page numbering used by other work packages. Each page of a work package has a page number of the form **XXXX-ZZ** where XXXX is the work package number (e.g. 0010 is work package 10) and ZZ represents the number of the page within that work package. A page number such as **0010-1/(2 Blank)** means that page 1 contains information but page 2 of that work package has been intentionally left blank. A page number in the form of **XXXX.X-ZZ** indicates that a revision has been made and a work package has been inserted.

Finding Information

The table of contents permits the reader to find information in the manual quickly. The reader should start here first when looking for a specific topic. The table of contents lists the topics contained within each chapter and the work package sequence number where it can be found.

Example: If the reader were looking for instructions on “Preventive Maintenance Checks and Services”, which is an operator maintenance topic, the table of contents indicates that operator maintenance information can be found in Chapter 5. Scanning down the listings for Chapter 5, “Preventive Maintenance Checks and Services” information can be found in WP 0009 and 0010 (i.e. Work Package 9 and 10).

An alphabetical index can be found at the back of the manual. It lists specific topics with the corresponding work package and page numbers.

Using the Repair Parts and Special Tools List (RPSTL)

Chapter 8 provides information to order the replacement parts and special tools necessary to perform all maintenance procedures given in this TM. A detailed explanation on how to use the RPSTL is provided in WP 0018, “Repair Parts and Special Tools Lists (RPSTL) Introduction”.

END OF WORK PACKAGE

CHAPTER 1
GENERAL INFORMATION, EQUIPMENT DESCRIPTION
AND THEORY OF OPERATION
FOR
MODULAR COMMAND POST SYSTEM (MCPS), SMALL

**OPERATOR, UNIT, AND DIRECT SUPPORT MAINTENANCE
MODULAR COMMAND POST SYSTEM (MCPS), SMALL
GENERAL INFORMATION**

SCOPE**Type of Manual**

Operator's, Unit, and Direct Support Maintenance Manual, including Repair Parts and Special Tools List (RPSTL) provides instructions for the set-up, operation, take down, maintenance, and repair procedures for all components of the Modular Command Post System (MCPS).

Purpose of Equipment

The MCPS is part of the Standard Integrated Command Post System (SICPS). It provides environmental protection to support command, control, communications and intelligence operations.

Special Feature

Lightweight frame assembly consisting of three separate collapsible sections can be quickly and easily set up by two soldiers.

Model Number and Equipment Name

No model number has been assigned at this time for the MCPS.

MAINTENANCE FORMS, RECORDS AND REPORTS

Department of the Army forms and procedures used for equipment maintenance will be those prescribed by (as applicable) DA PAM 750-8, Functional Users Manual for the Army Maintenance Management System (TAMMS); DA PAM 738-751, Functional Users Manual for the Army Maintenance Management Systems – Aviation (TAMMS-A); or AR 700-138, Army Logistics Readiness and Sustainability.

REPORTING EQUIPMENT IMPROVEMENT RECOMMENDATIONS (EIR)

If your MCPS needs improvement, let us know. Send us an EIR. You, the user, are the only one who can tell us what you don't like about your equipment. Let us know why you don't like the design or performance.

If you have Internet access, the easiest and fastest way to report problems or suggestions is to go to <https://aeps.ria.army.mil/aepspublic.cfm> (scroll down and choose the "Submit Quality Deficiency Report" bar). The Internet form lets you choose to submit an Equipment Improvement Recommendation (EIR), a Product Quality Deficiency Report (PQDR) or a Warranty Claim Action (WCA).

You may also submit your information using an SF 368 (Product Quality Deficiency Report). You can send your SF 368 via e-mail, regular mail, or facsimile using the addresses/facsimile numbers specified in DA PAM 750-8, Functional Users Manual for the Army Maintenance Management System (TAMMS). We will send you a reply.

CORROSION PREVENTION AND CONTROL (CPC)

Corrosion Prevention and Control (CPC) of Army materiel is a continuing concern. It is important that any corrosion problems with this item be reported so that the problem can be corrected and improvements can be made to prevent the problem in future items. Corrosion specifically occurs with metals. It is an electrochemical process that causes the degradation of metals. It is commonly caused by exposure to moisture, acids, bases, or salts. An example is the rusting of iron. Corrosion damage in metals can be seen, depending on the metal, as tarnishing, pitting, fogging, surface residue, and/or cracking. Plastics, composites, and rubbers can also degrade. Degradation is caused by thermal (heat), oxidation (oxygen), solvation (solvents), or photolytic (light, typically UV) processes. The most common exposures are excessive heat or light. Damage from these processes will appear as cracking, softening, swelling, and/or breaking. SF Form 368, Product Quality Deficiency Report should be submitted to the address specified in DA PAM 750-8, Functional Users Manual for the Army Maintenance Management System (TAMMS).

DESTRUCTION OF ARMY MATERIEL TO PREVENT ENEMY USE

Destruction procedures for MCPS components covered in this manual are described in TM 750-244-3.

PREPARATION FOR STORAGE OR SHIPMENT

Before placing the MCPS in administrative storage or preparing the system for shipment, current maintenance services must be applied; defects and failures corrected; and Modification Work Orders (MWOs) applied.

Preparation for Storage

To prepare the MCPS equipment for storage, clean and dry the fabric sections and other components as described in WP 0009. Perform operator PMCS as specified in WP 0010. Pack the fabric and frame assemblies into the transport bags as described in WP 0005. Place bags onto a wooden pallet and store in a building, shed, or other dry place. Store the light set in its storage container. The mapboard and field table should be packed in a wooden crate of suitable size and stored in a dry place.

Preparation for Shipment

Prepare the MCPS for shipment by packing components into the wooden crate, using the original packing material, in which they were received. Strap crates onto wooden pallet. If the MCPS components are to be stored without regular PMCS being performed, consult FM 38-701 for preservation requirements.

WARRANTY INFORMATION

The MCPS is warranted by the manufacturer. The warranty starts on the date found in block 23 of DA Form 2408-9, Equipment Control Record. Report all defects to your supervisor, who will take appropriate action.

NOMENCLATURE CROSS-REFERENCE LIST

COMMON NAME	OFFICIAL NAME
7-inch Spacer	Bracket, Tent Frame
Detent	Pin, Quick Release
Light	Luminaire
Light Set	Light Set, General Illumination
Mapboard	Board, Map, Complexing
MCPS	Modular Command Post System, Small
Table	Table Field, Folding Legs, Metal

LIST OF ABBREVIATIONS/ACRONYMS

⁰ C	Degree(s) Celsius (Centigrade)	LAR	Logistics Assistance Representative
⁰ F	Degree(s) Fahrenheit	Lb	Pound(s)
AAL	Additional Authorization List	Lt	Liter(s)
AC	Alternating Current	M	Meter(s)
AMP, A	Ampere(s)	MAC	Maintenance Allocation Chart
AR	Army Regulation	MC	Male Connection
ASH	Army Space Heater	MSDS	Material Safety Data Sheet
AVIM	Aviation Intermediate Maintenance	MTD	Munitions Technologies Division
AVUM	Aviation Unit Maintenance	MTOE	Modified Table of Organization and Equipment
BII	Basic Issue Item	MWO	Modification Work Order
BOI	Basis of Issue	N/A	Not Applicable
CAGEC	Commercial And Government Entity Code	NBC	Nuclear, Biological, and Chemical
CARC	Chemical Agent Resistant Coating	NIIN	National Item Identification Number
CB	Circuit Breaker	NSN	National Stock Number
CCW	Counterclockwise	ORD	Operational Requirements Document
cm	Centimeter(s)	oz.	Ounce
COEI	Components of End Item	P/N	Part Number
CPC	Corrosion Prevention and Control	PAM	Pamphlet
CPVC	Chlorinated Polyvinyl Chloride	PDISE	Power Distribution Illumination System, Electrical
CTA	Common Table of Allowances	PLC	Programmable Logic Controller
Cu Ft	Cubic Foot/Feet	PMCS	Preventive Maintenance Checks and Services
CW	Clockwise	POL	Petroleum, Oil and Lubricant
DA	Department of the Army	PPCIE	Personal Protection Clothing and Individual Equipment
DISE	Distribution Illumination Systems, Electrical	PR	Pair
DMWR	Depot Maintenance Work Requirement	Psi	Pound(s) per Square Inch
DS	Direct Support	QDC	Quick Disconnect
DS2	Decontaminating Solution	qt(s)	Quart
ea	Each	Qty	Quantity
ECU	Environmental Control Unit	RPSTL	Repair Parts and Special Tools List
EIR	Equipment Improvement Recommendation	RTV	Room Temperature Vulcanized
EMP	Electromagnetic Pulse	RWS	Rigid Wall Shelter
ESD	Electrostatic Discharge	SF	Standard Form
FC	Female Connection	SHC	Space Heater, Convective
FDECU	Field Deployable Environmental Control Unit	SICPS	Standardize Command Post System
FM	Field Manual	SMR	Source, Maintenance and Recoverability
ft	Foot, feet	SOP	Standard Operating Procedure
GFCI	Ground Fault Circuit Interrupt	Sq Ft	Square Foot/Feet
GPH	Gallons Per Hour	SRA	Specialized Repair Activity
GPM	Gallons per Minute	STB	Standard Tropical Bleach
HCI	Hardness Critical Item	TAMMS	The Army Maintenance Management System
hp	Horsepower	TAMMS-A	The Army Maintenance Management System - Aviation
hr	Hour	TDA	Table Of Distribution and Allowances
Hz	Hertz	TEMPER	Tent, Extendable, Modular, Personnel
IAW	In Accordance With	TM	Technical Manual
in	Inch(es)	TMDE	Test, Measurement, and Diagnostic Equipment
ISO	International Organization for Standardization	TOE	Table of Organization and Equipment
JTA	Joint Table of Allowance	U/M	Unit of Measure
Kg	Kilogram(s)	WCA	Warranty Claims Action
kPa	Kilopascal(s)		
kw	Kilowatt(s)		

QUALITY OF MATERIAL

Material used for replacement, repair, or modification must meet the requirements of this TM. If quality of material requirements are not stated in this TM, the material must meet the requirements of the drawings, standards, specifications, or approved engineering change proposals applicable to the subject equipment.

SAFETY, CARE, AND HANDLING

Be alert and note **WARNINGS, CAUTIONS, and NOTES**. These provide for safe operation of the equipment, and protect you and your equipment from injury and damage.

No precautions regarding radioactive components or electrostatic discharge (ESD) are advised.

END OF WORK PACKAGE

**OPERATOR, UNIT AND DIRECT SUPPORT MAINTENANCE
MODULAR COMMAND POST SYSTEM (MCPS), SMALL
EQUIPMENT DESCRIPTION AND DATA**

EQUIPMENT CHARACTERISTICS, CAPABILITIES AND FEATURES

The MCPS is available in green or tan color for use in different types of terrain. Except for color, the characteristics, capabilities and features of both versions are identical. Separate bootwalls are available to connect the MCPS to the M577, the Rigid Wall Shelter (RWS), and the TEMPER tent system.

Characteristics

- Usable in a variety of climates.
- Constructed of lightweight materials.
- Deployed in forward battle areas.
- Provides blackout protection.

Capabilities and Features

- MCPS may be utilized as a stand-alone structure, complexed with any number of MCPSs, or connected to a variety of tactical vehicles.
- Can be set-up quickly by two soldiers under normal operating conditions.
- MCPS sidewalls are interchangeable to form different configurations.
- Frame assembly consists of three collapsible sections made of aluminum tube that unfold and connect to form a single frame.
- MCPS uses quick release fasteners throughout.
- MCPS is made of water resistant, mildew resistant, polyester duck fabric.
- MCPS frame can be adjusted to offset sloping ground.

LOCATION AND DESCRIPTION OF MAJOR COMPONENTS

Tent Frame Assembly

End Wall Frame Assembly. The end wall frame assembly (**Figure 1, Item 1**) is constructed of extruded aluminum tubing and supports the front or rear of the MCPS. It consists of two upper (**Figure 1, Item 2**) and two lower (**Figure 1, Item 3**) leg assemblies, two rafter assemblies (**Figure 1, Item 4**), two end wall fitting assemblies (**Figure 1, Item 5**), an end peak fitting assembly (**Figure 1, Item 6**), a left hand purlin (**Figure 1, Item 7**), a cable assembly (**Figure 1, Item 8**), and a cord (**Figure 1, Item 9**). Two end wall frame assemblies are required to set up the MCPS.

Center Wall Frame Assembly. The center wall frame assembly (**Figure 1, Item 10**) is constructed of extruded aluminum tubing and supports the center portion of the MCPS. It consists of two upper (**Figure 1, Item 11**) and two lower (**Figure 1, Item 12**) leg assemblies, two midwall fitting assemblies (**Figure 1, Item 13**), two rafter assemblies (**Figure 1, Item 14**), a peak center joint (**Figure 1, Item 15**), two right hand (**Figure 1, Item 16**) and two left hand (**Figure 1, Item 17**) purlins, a cable assembly (**Figure 1, Item 18**), and a cord (**Figure 1, Item 19**). One center wall frame assembly is required to set up the MCPS.

Telescopic Pole Assemblies. The telescopic pole assemblies (**Figure 1, Item 20**) are constructed of aluminum alloy tubing. They support the covered entrance way. The upper part fits through grommets located in the entrance way roof assembly. The poles also fit through two pole holders on the left and right blackout door assemblies. Two telescopic pole assemblies are provided with each MCPS frame assembly.

Tent Frame Bracket. 7-inch tent frame brackets (**Figure 1, Item 21**) are used to ensure the correct spacing of adjacent leg assemblies when tents are complexed.

Tent Pins. Eight 12-inch steel tent pins (**Figure 1, Item 22**) are issued for staking down the tent frame leg assemblies, and eight 24-inch wooden tent pins (**Figure 1, Item 23**) are issued for staking down the tent lines.

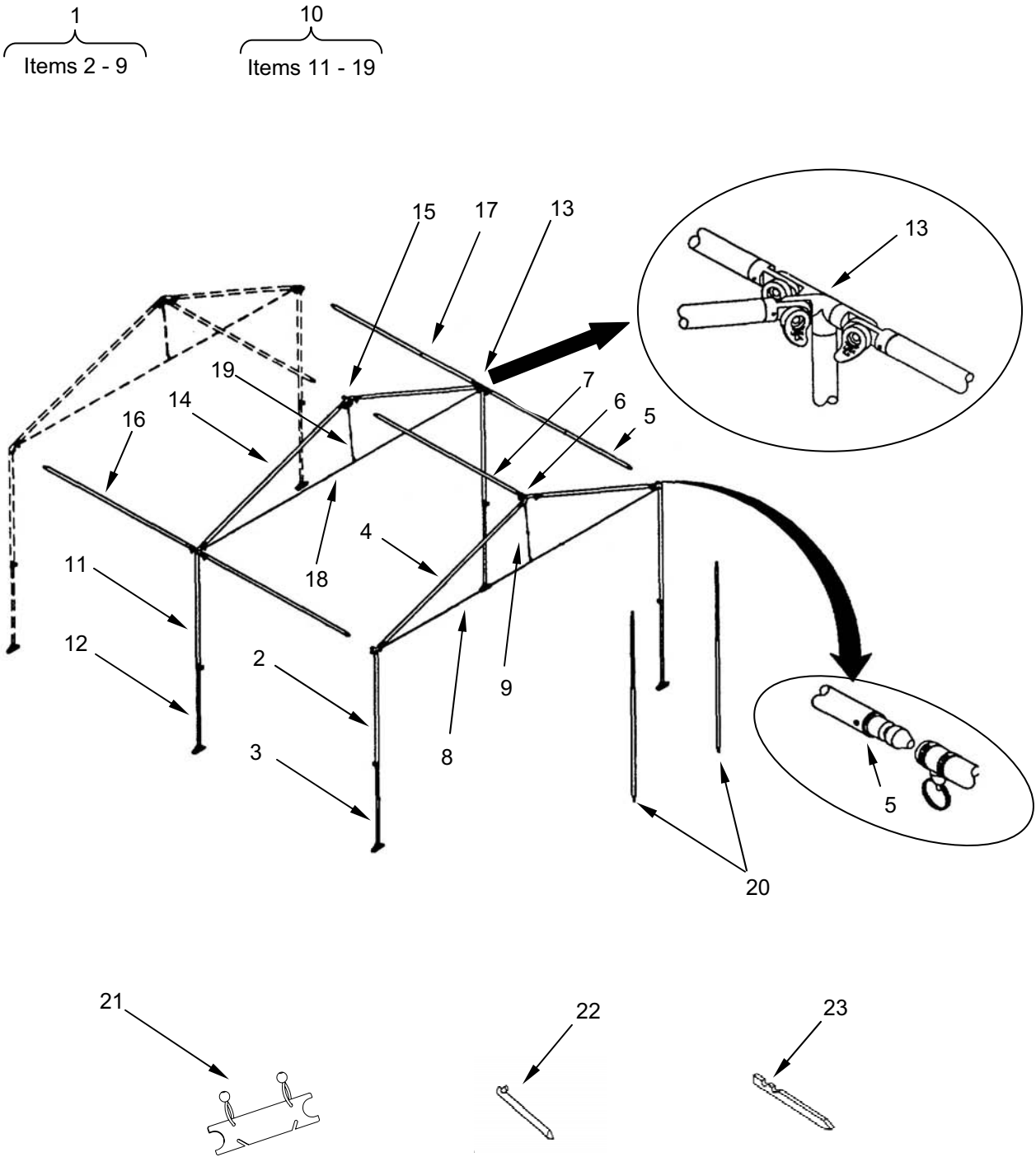

Figure 1. Tent Frame Assembly.

Tent Fabric Assemblies

Plain Wall Assembly. The plain wall (**Figure 2, Item 1**) is constructed of mildew and flame resistant polyester duck cloth and is approximately 12 feet, 6 inches wide by 8 feet high. On the inside, eight quick release male fasteners are located approximately 18 inches apart along the top edge. Four female quick release fasteners are also located along the top, spaced about 40 inches apart. Seven buckle assemblies with quick release female fasteners are located approximately 12 inches apart and 22 inches from the edge along each side, with three more approximately 5 feet apart and 24 inches above the bottom edge. A 2-inch wide hook fastener strip is located along the top, the upper corners, and the outer edge of the right side. An identification label is sewn to the inside of the wall. On the outside, four roll-up straps are located approximately 40 inches apart along the top, and seven small buckle assemblies with quick release female fasteners are located approximately 12 inches apart and 22 inches from the edge along the right side. In addition, seven side straps with quick release male fasteners are located about 12 inches apart along the outer edge of each side. A 2-inch wide pile fastener strip is located along the top, the upper corners, and the fold line of the right side. One plain wall is issued with each MCPS.

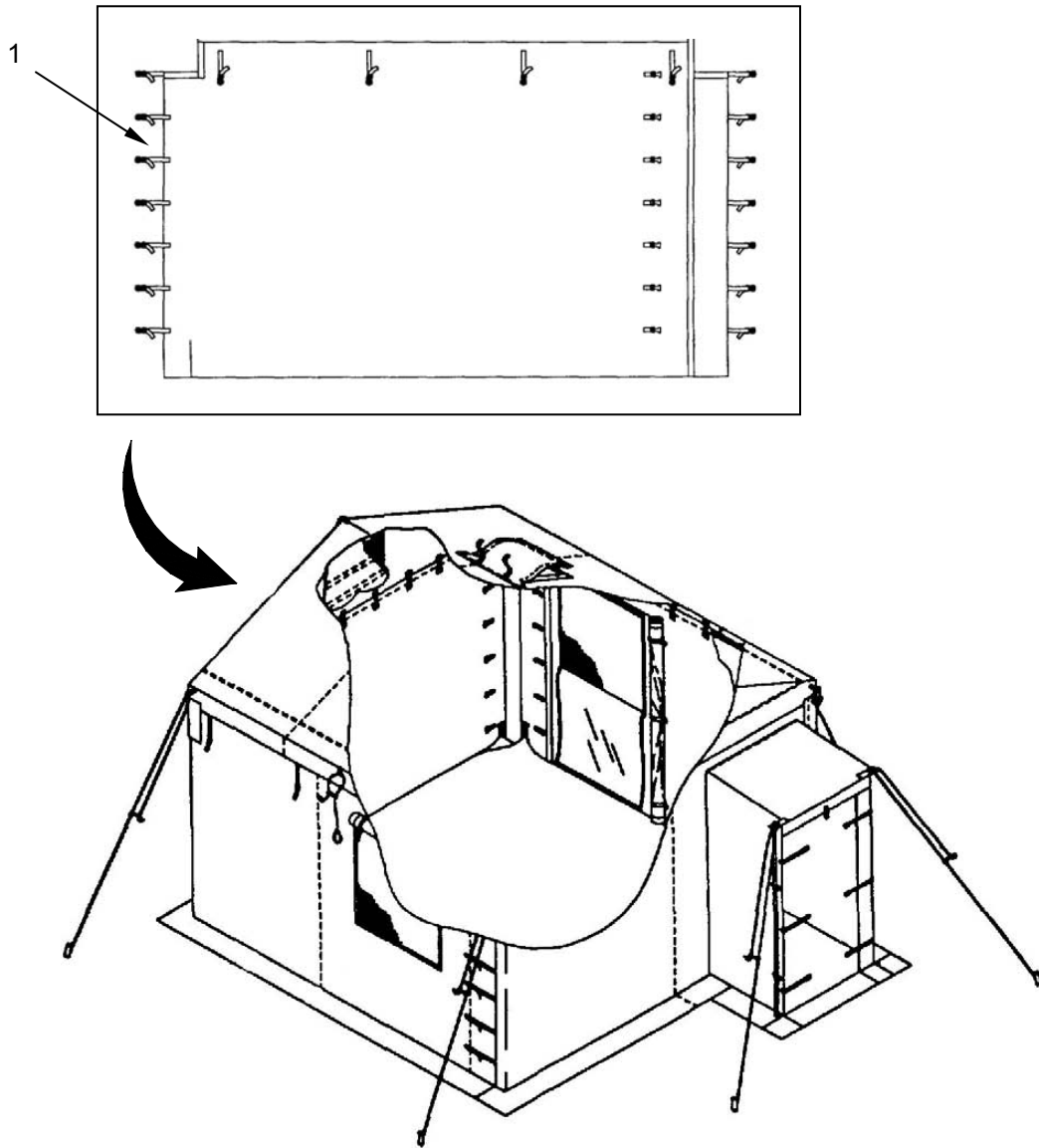

Figure 2. Plain Wall Assembly (Type I Shown).

Window Wall Assembly. The window wall (**Figure 3, Item 1**) is similar to the plain wall except that it contains a 38-inch by 38-inch clear plastic window, a nylon webbing screen, and a window flap. The screen is sewn into the window opening. The window is sewn to the bottom seam of the window opening and 1-inch wide pile fastener strips are located around its outer edges. A 1-inch wide hook fastener strip is located around the inside seams of the window opening. On the outside, a window flap with 1-inch wide pile fastener strips along its inside edge is sewn to the upper window seam. Two, $\frac{3}{4}$ -inch wide roll up straps are located just above the window flap. A 1-inch wide hook fastener strip is located around the outside seam of the window opening. Two window walls are issued with each MCPS.

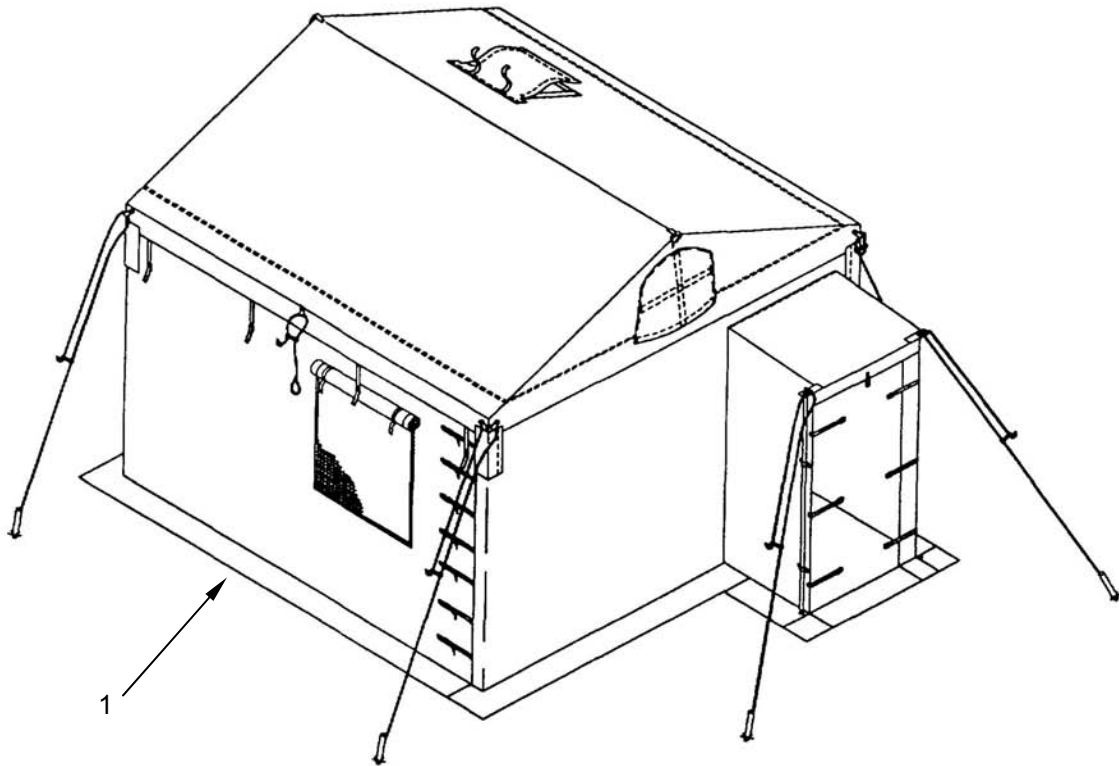

Figure 3. Window Wall Assembly (Type I Shown).

Horizontal ECU/Window Wall Assembly. The horizontal ECU/window wall (**Figure 4, Item 1**) is similar to the window wall assembly with the exception that two 18-inch ECU duct openings have been fitted. One horizontal ECU/window wall assembly is issued with each Type III MCPS.

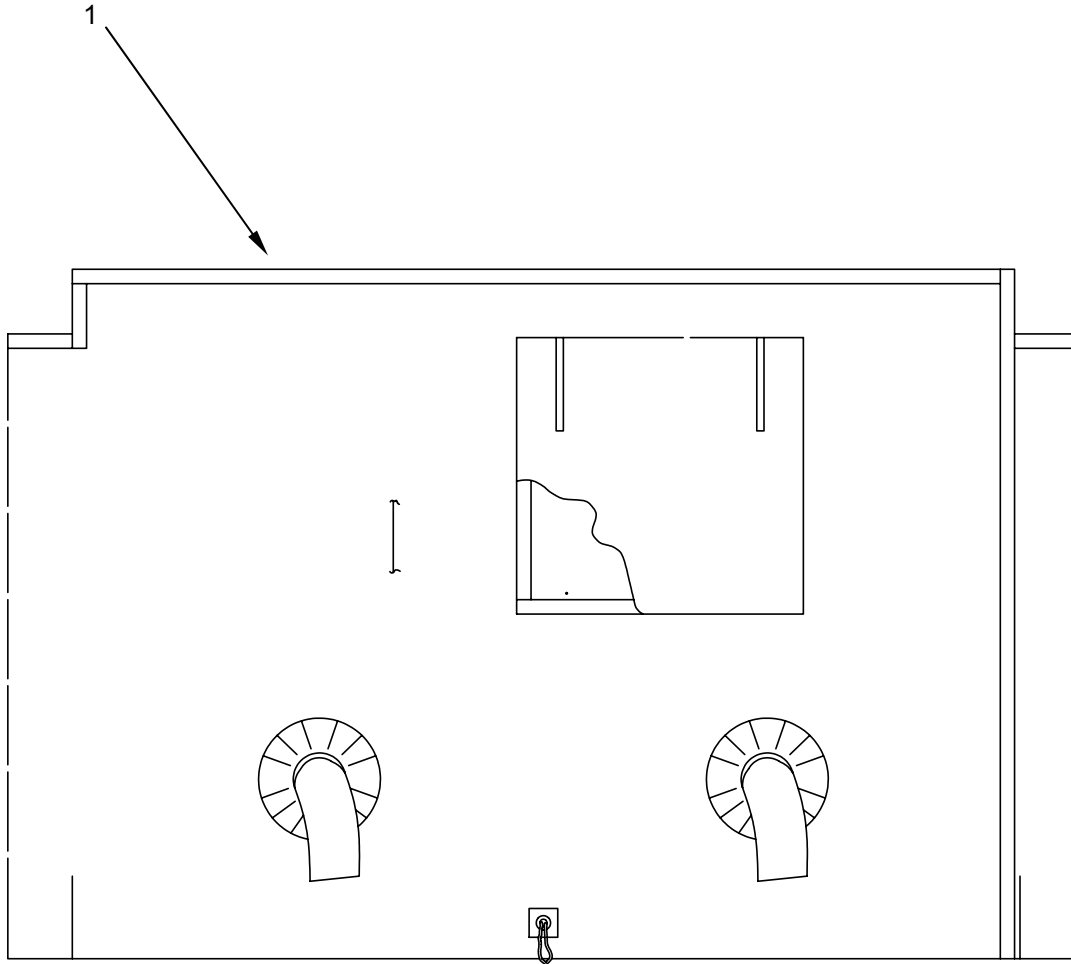

Figure 4. Horizontal ECU/Window Wall Assembly.

Entrance Way Assembly. The entrance way wall (**Figure 5, Item 1**) is constructed similar to the plain wall except that there are no quick release female fasteners located along the inside top. Additionally, this wall incorporates a 36-inch wide covered entrance way. Inner blackout doors cover the entrance way opening in the wall. A 1-inch wide pile fastener strip is sewn along its top edge. A 1-inch wide hook fastener strip is located along the top of the entrance way wall opening. Left and right blackout door assemblies are sewn to the outer seams of the entrance way wall opening. Both have two pole holders located on the outside approximately 35 inches apart, and three buckle assemblies with quick disconnect female fasteners on the inside. A grommet is located on each upper and lower corner of the left and right blackout door assemblies. A male quick disconnect fastener is located on the front center of the entrance way roof. An identification label is sewn on the inside of the wall. The covered entrance way allows for entry into and exit from the tent, enhances ventilation and helps maintain light discipline. One entrance way wall is issued with each MCPS.

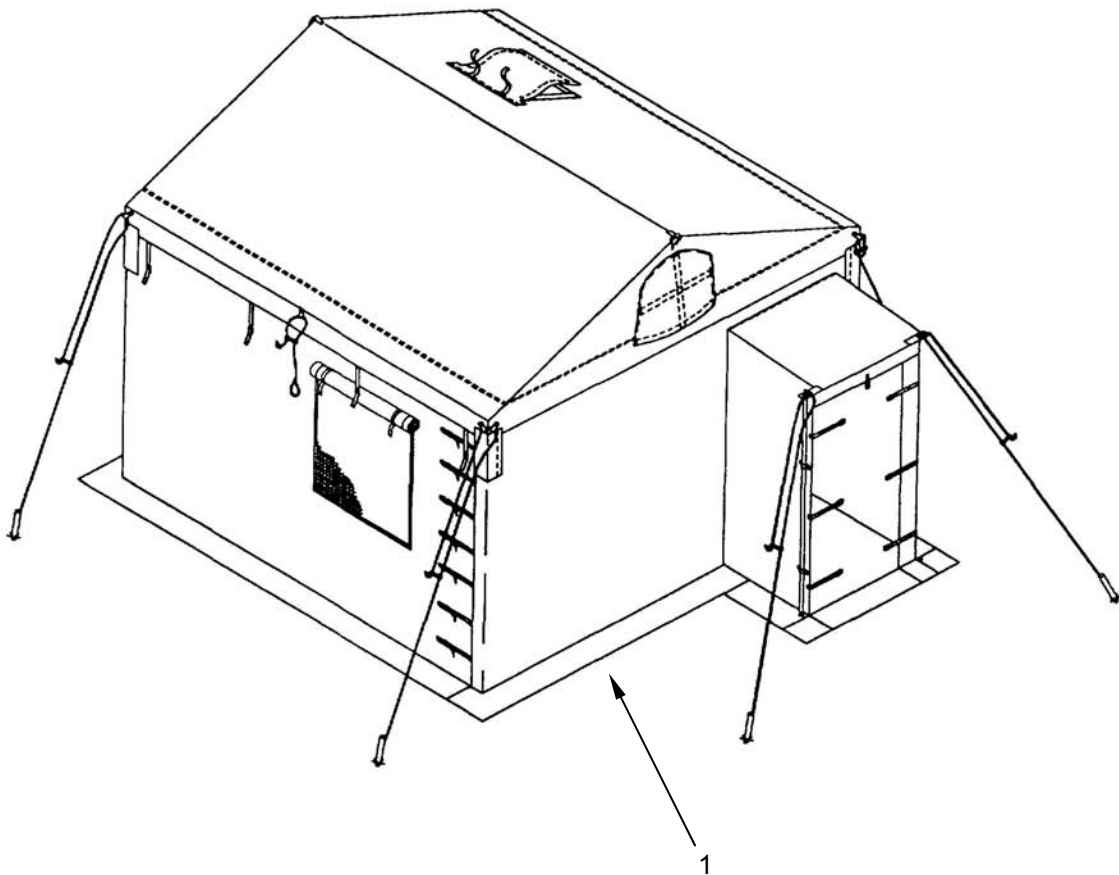

Figure 5. Entrance Way Assembly (Type I Shown).

Roof Cap Assembly. The roof cap (**Figure 6, Item 1**) is constructed of the same material as the walls. On the inside, 8-inch wide reinforcements are located along the front and rear, with quick disconnect female fasteners located approximately 18 inches apart. Two strips of 2-inch wide hook fastener are sewn to the reinforcement. Along the sides, 16 ½ -inch reinforcements are located, with quick disconnect female fasteners spaced approximately 18 inches apart. Two strips of 2-inch wide hook fastener are sewn to the reinforcement below the fasteners. In addition, strap assemblies with quick disconnect fasteners are located on the upper part of the reinforcement. An 11-inch by 24-inch vent flap assembly, consisting of an insect screen covered by inside and outside vent flaps, is located at each end of the roof cap. A 5-inch by 6 ¼ -inch stove pipe opening is located within an 18-inch by 18-inch stove pipe shield. A flap with tie tapes is sewn to the upper seam of the stove pipe shield opening. A strip of 2-inch wide pile fastener is sewn to the inside edges of the flap, and a 2-inch wide hook fastener strip is sewn around the outside edges of the stove pipe shield opening. A corner flap assembly is located at each exterior corner to provide protection from water. Strips of hook fastener are sewn to the underside of the corner flap assembly. Rope chapes are located at the peaks and sides of the roof cap. An identification label is located on the inside. One roof cap is provided with each MCPS.

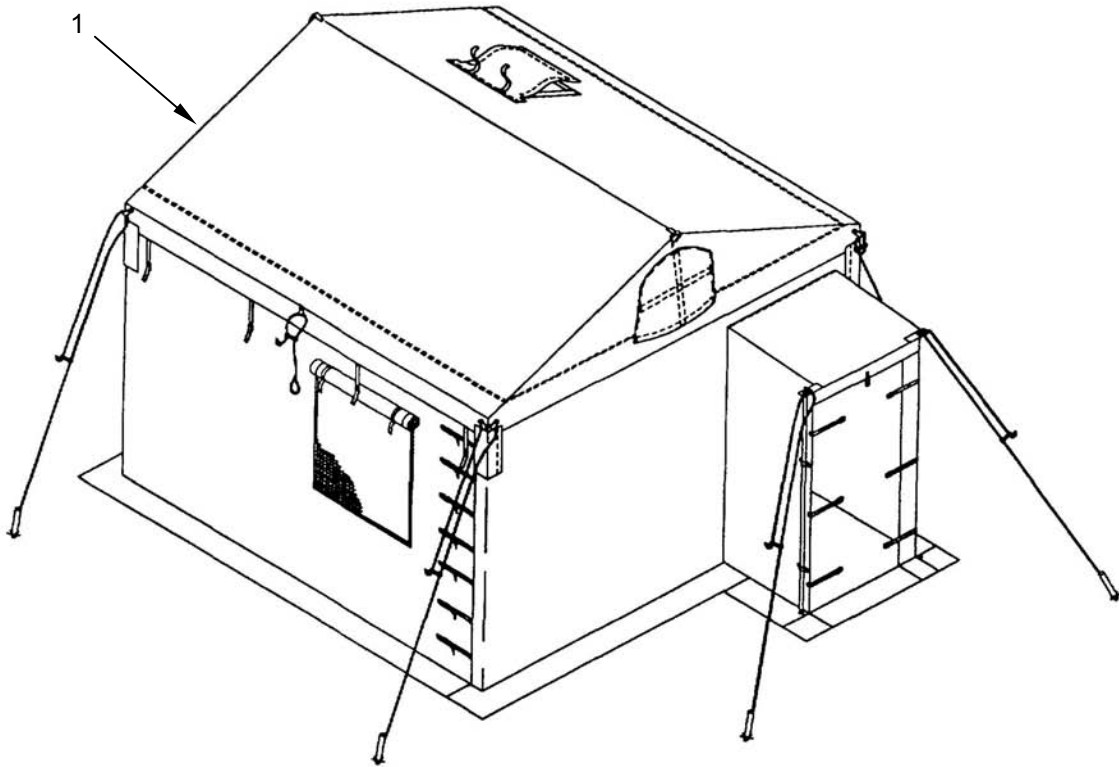

Figure 6. Roof Cap Assembly (Type I Shown).

Rain Gutter Assembly. The rain gutter (**Figure 7, Item 1**) is constructed of the same material as the plain wall. It is approximately 13 feet, 3 inches long and 19 inches wide. Eight quick disconnect male fasteners are located 18 inches apart along each side. A strip of 2-inch hook fastener is sewn to each outside edge, and a strip of 2-inch pile fastener is sewn to each inside edge. Strips of 2-inch wide hook and pile fasteners are located on each end flap. The rain gutter provides the means to complex Modular Command Post Systems together and provide protection from the weather when two or more systems are joined. An identification label is sewn on the side of the gutter. One rain gutter is provided with each MCPS.

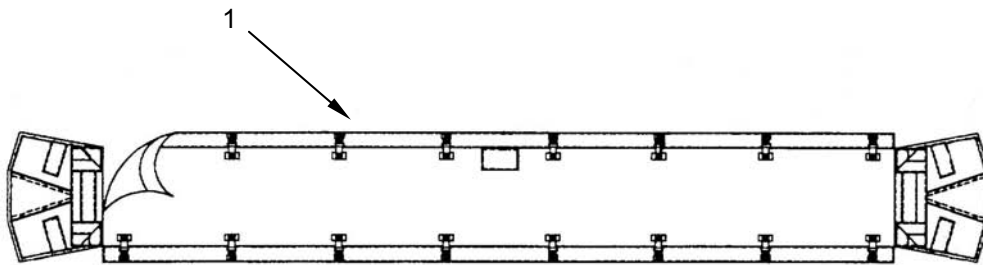

Figure 7. Rain Gutter Assembly.

Floor Assembly. The floor (**Figure 8, Item 1**) is constructed of a coated cloth material and is 12 feet, 8 inches square. Three quick disconnect male fasteners are located along each side of the floor. It covers the entire floor area of the tent and provides protection from dirt, dust, and moisture. An identification label is sewn onto the side of the floor. One floor is issued with each MCPS.

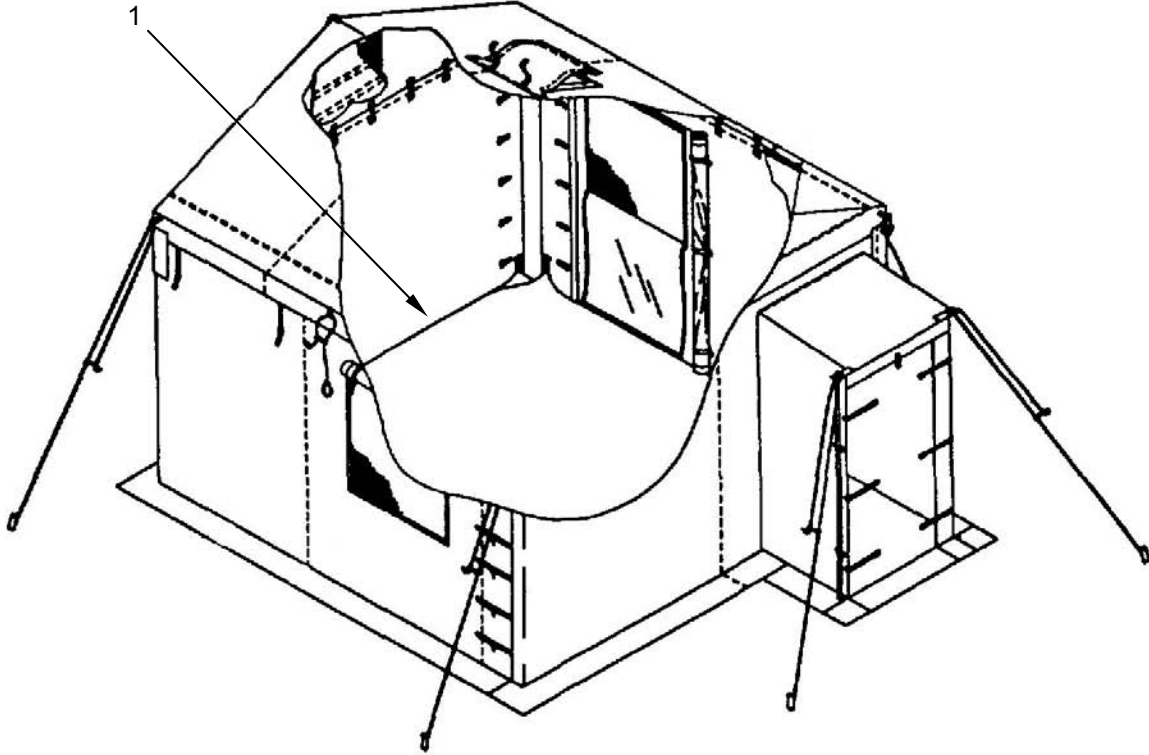

Figure 8. Floor Assembly (Type I Shown).

Plain Wall Liner. The plain wall liner (**Figure 9, Item 1**) is constructed of a lightweight, pajama check weave cloth and is approximately 12 feet wide by 7 feet high. On the inside, eight quick release male fasteners are located approximately 18 inches apart along the top edge. Seven buckle assemblies with quick release female fasteners are located approximately 12 inches apart and 22 inches from the edge along each side, with three more located approximately 5 feet apart and 12 inches above the bottom edge. An identification label is sewn to the inside. In addition, seven side straps with quick release male fasteners are located approximately 12 inches apart along the outer edge of each side. On the outside, a 2-inch strip of pile fastener is sewn along the upper seam of the liner. The plain wall liner provides insulation and can be used as outside wall in hot weather during daylight hours. The liner also assists in providing light discipline. One plain wall liner is issued with each Type I MCPS.

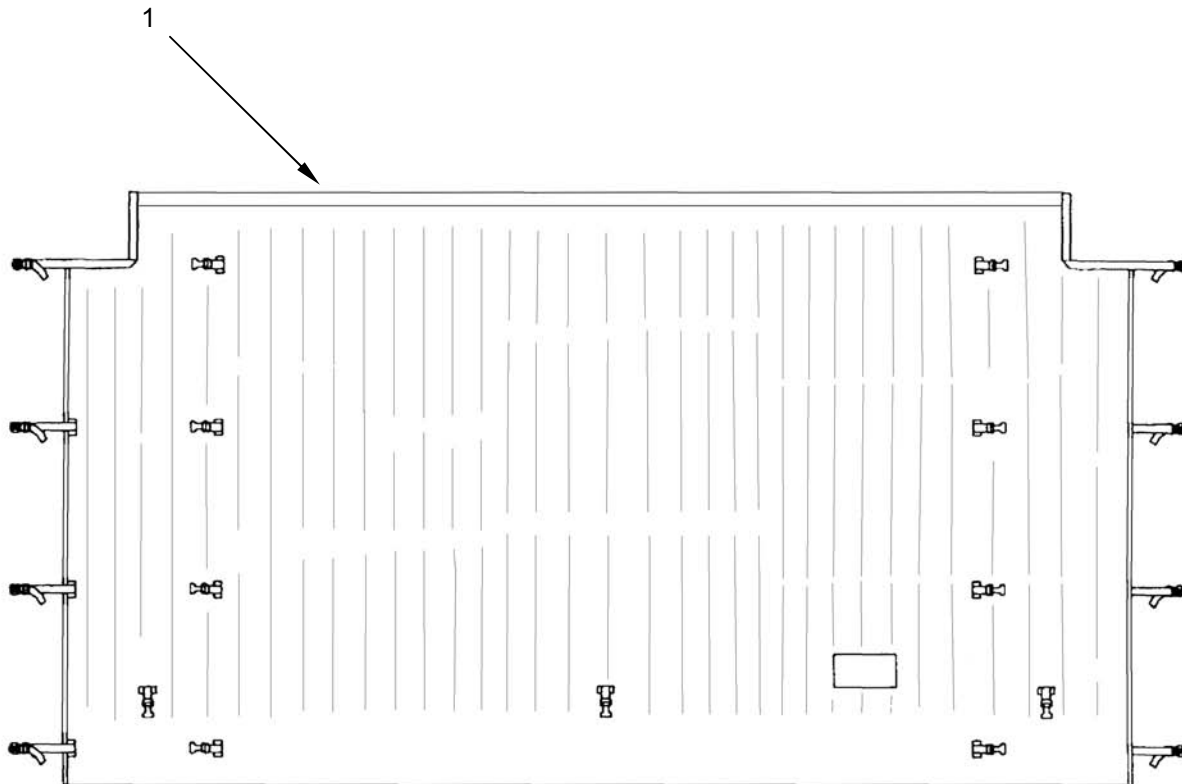

Figure 9. Plain Wall Liner.

Entrance Way/Window Wall Liner. The entrance way/ window wall liner (**Figure 10, Item 1**) is constructed similar to the plain wall liner except that it contains an approximately 6 foot ½-inch high and 3-foot wide door. A quick release male fastener is located on the upper, inside edge of the door and a quick disconnect female fastener in corresponding location on the liner. A strip of 1-inch pile fastener is located along the left side and along the top of the liner door opening. A strip of 1-inch hook fastener is sewn to the outer edge and top of the door. In addition seven quick release female fasteners are located on the outside along the door opening. Three entrance way wall/window wall liners are issued with each Type I MCPS.

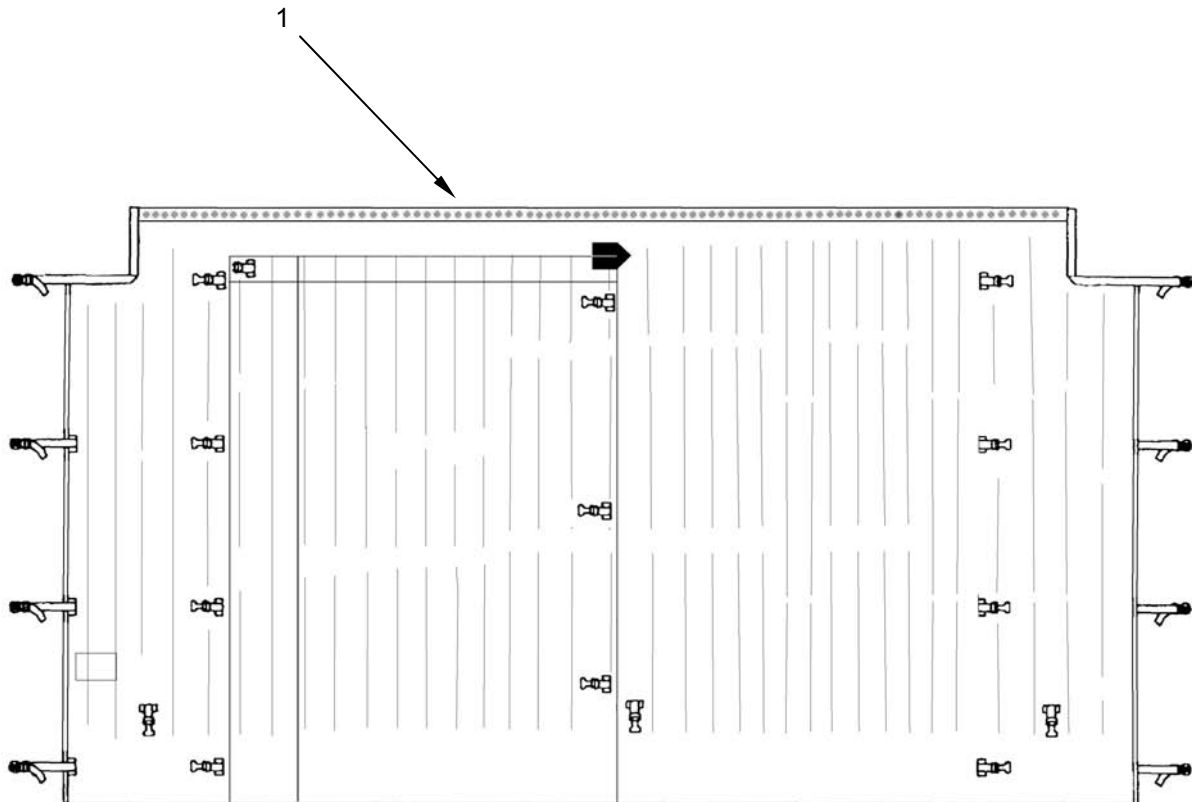

Figure 10. Entrance Way/Window Wall Liner.

Insulated Liners

ECU/Window Wall Insulated Liner. The ECU/Window Wall Insulated Liner (**Figure 11, Item 1**) is constructed similar to the entrance way/ window wall liner in that it contains a 38-inch window flap (**Figure 11, Item 2**). The liner is constructed of an insulating fabric to prevent heat transfer both to and from the outside in extreme cold and extreme heat situations. Two 18-inch heating/air conditioning elastic socks with flaps (**Figure 11, Item 3**) are horizontally positioned below the window closure. Two ECU/Window Wall Insulated Liners are issued with each Type III MCPS.

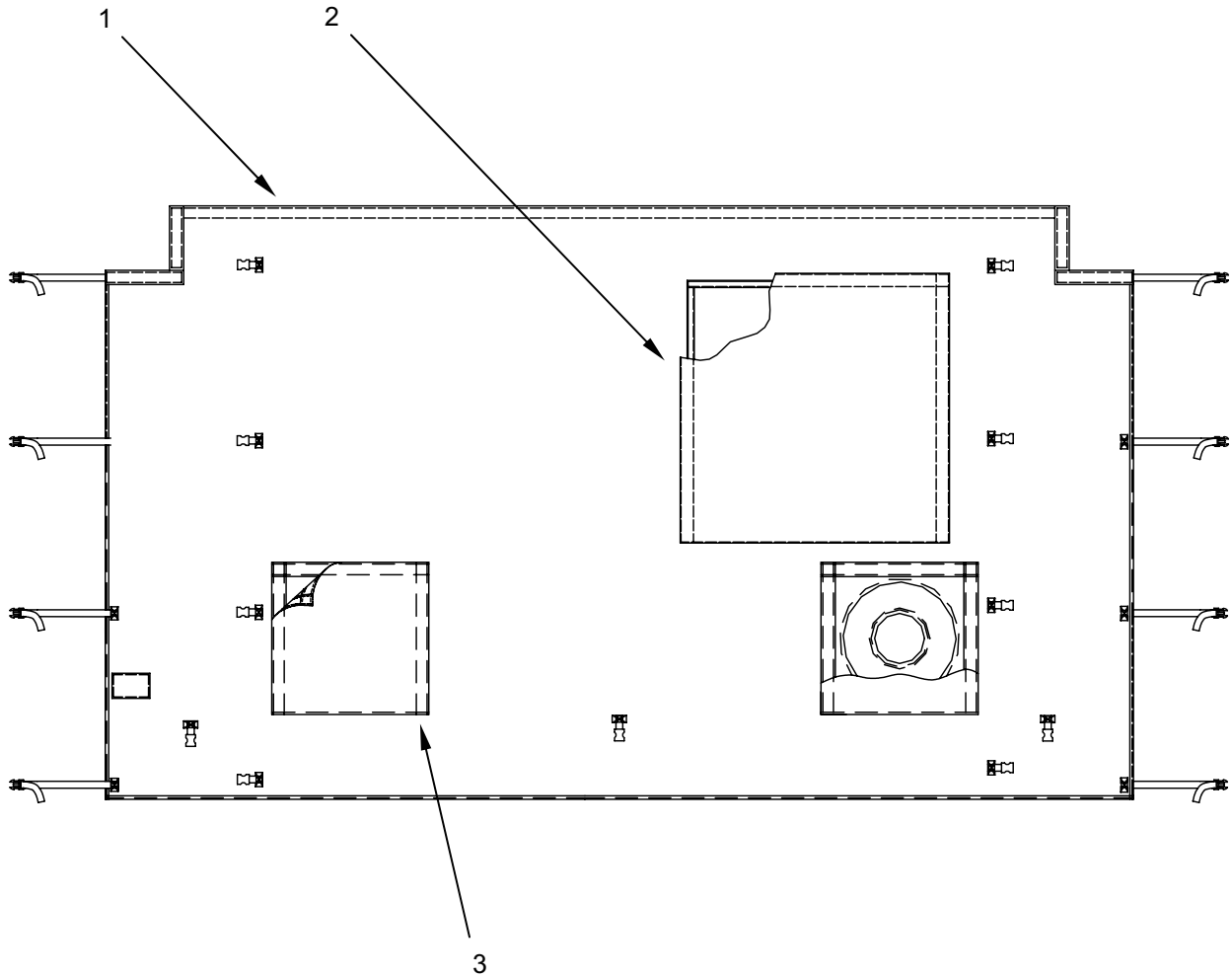

Figure 11. ECU/Window Wall Insulated Liner.

Entrance Way Insulated Liner. The Entrance Way Insulated Liner (**Figure 12, Item 1**) is identical in construction to the ECU/Window Wall Liner, except that no heating/air conditioning elastic socks are fitted.

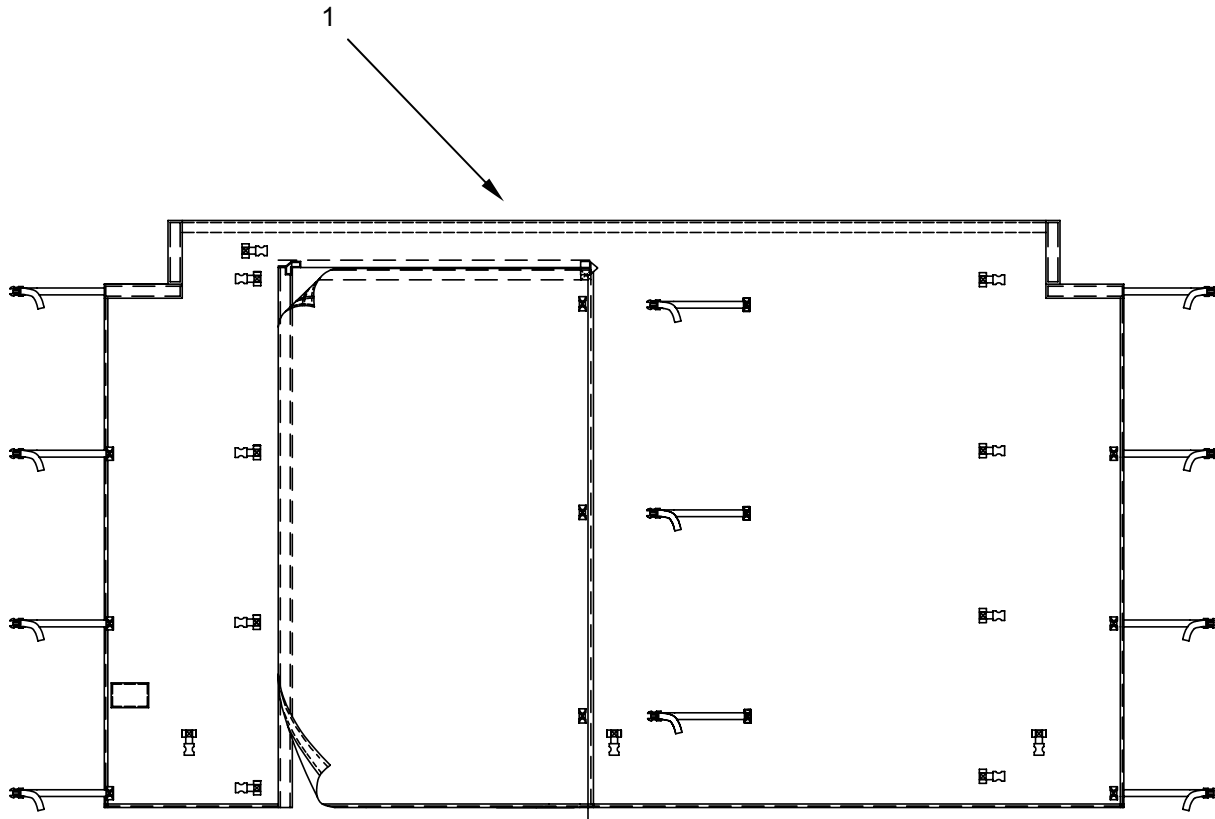

Figure 12. Entrance Way Insulated Liner.

Boot Wall Assembly Insulated Liner. The Boot Wall Assembly Insulated Liner is a two piece assembly fitted to the MCPS when a RWS bootwall interface is used. One piece (**Figure 13, Item 1**) is used in place of a wall liner, and the second piece (**Figure 13, Item 2**) lines the interior of the boot. A 5-foot wide center panel (**Figure 13, Item 3**) may be rolled up to allow access to the RWS.

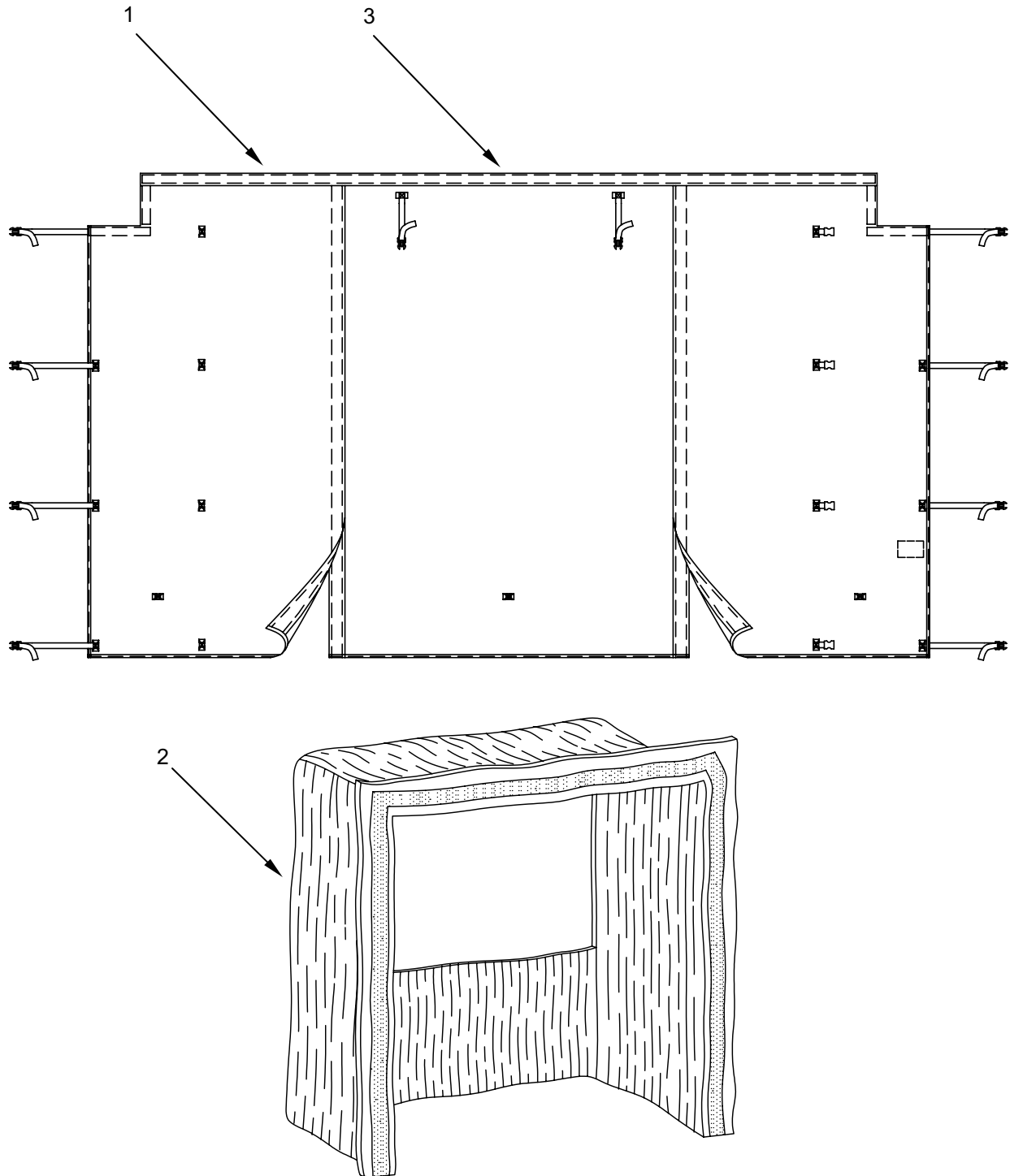

Figure 13. Boot Wall Assembly Insulated Liner.

Roof Cap Assembly Insulated Liner. The Roof Cap Assembly Insulated Liner (**Figure 14, Item 1**) is constructed of insulating fabric and designed to fit under the roof cap, strapped to the underside of the tent frame ridge purlins and retaining in place by hook and pile fasteners (**Figure 14, Item 2**). A 17-inch vent flap opening (**Figure 14, Item 3**) is fitted to allow for an exhaust stacks of an internal heater. The roof cap liner must be fitted to the tent regardless of whether additional wall liners are fitted.

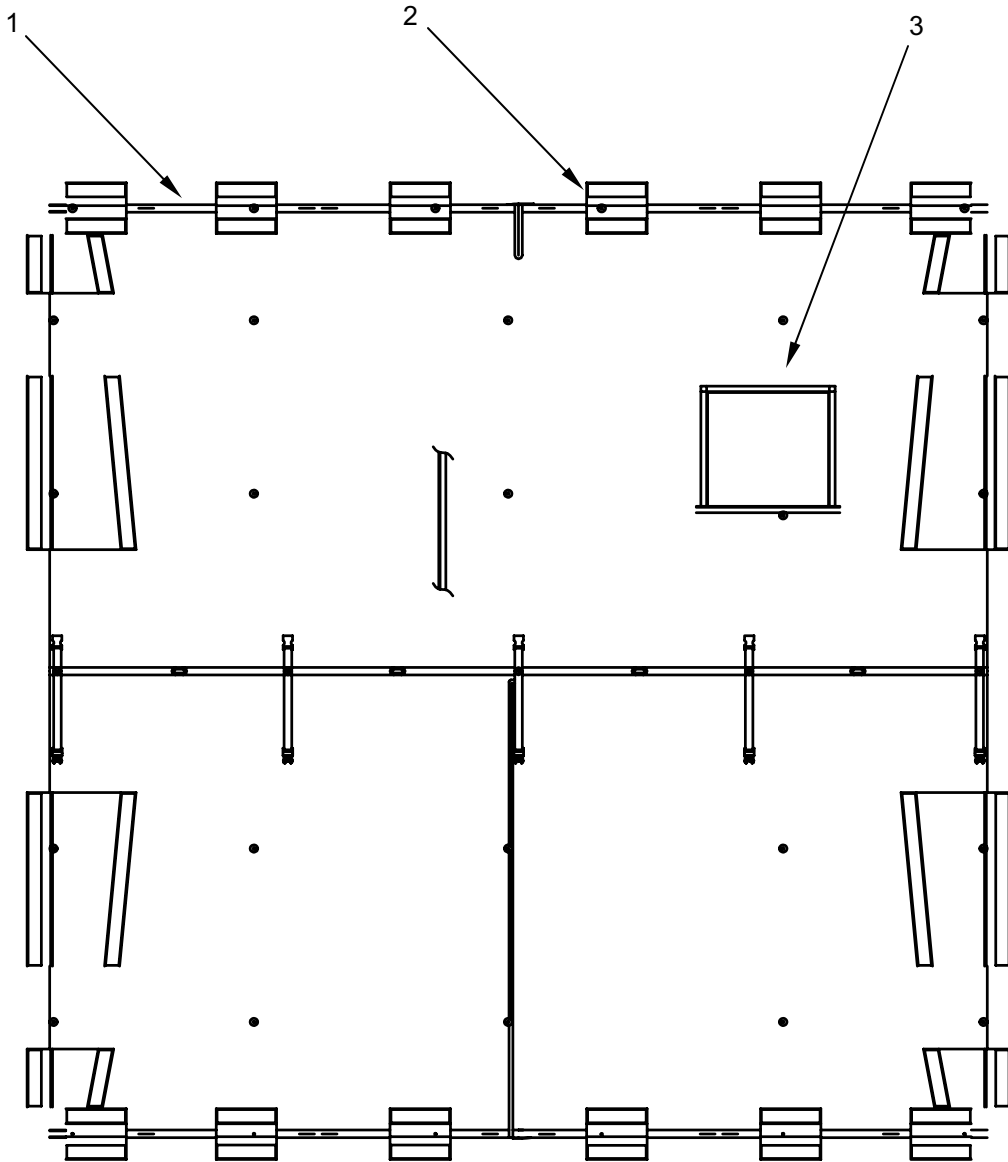

Figure 14. Roof Cap Assembly Insulated Liner.

Rain Gutter Assembly Insulated Liner. The Rain Gutter Insulated Liner (**Figure 15, Item 1**) is a 13-foot insulated fabric assembly designed to be fitted beneath the rain gutters when tents are complexed. The rain gutter liner assembly is retained in place by hook and pile fasteners.

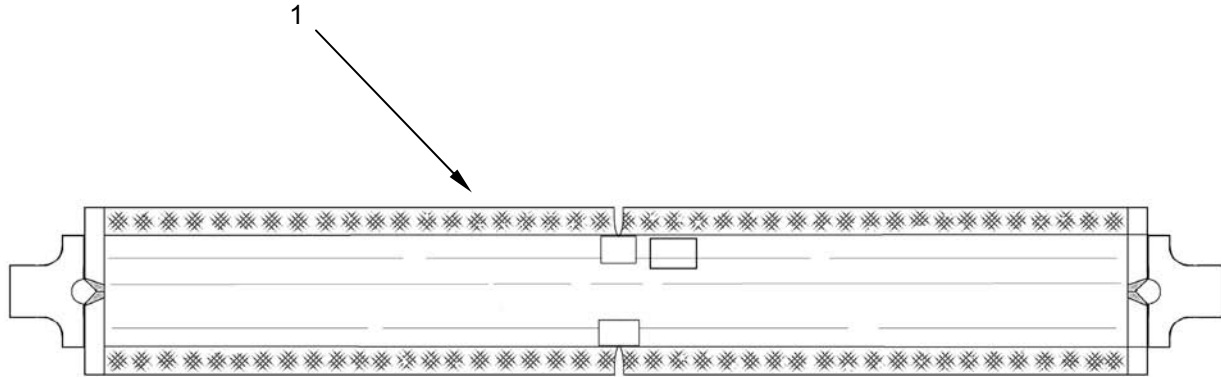

Figure 15. Rain Gutter Assembly Insulated Liner.

Field Table Assembly. Two field table assemblies (**Figure 16, Item 1**) are included with the MCPS. Folding leg assemblies (**Figure 16, Item 2**) allow the field table assemblies to be stored in a minimum amount of space.

Mapboard Assembly. Four mapboard assemblies (**Figure 16, Item 3**) are provided with the Type I MCPS. Each mapboard assembly consists of a rollable overlay (**Figure 16, Item 4**) and a rigid overlay (**Figure 16, Item 5**), fastened to a plywood panel (**Figure 16, Item 6**) by means of locator assemblies (**Figure 16, Item 7**). Complexers (**Figure 16, Item 8**) on the back of the panel allow mapboard assemblies to be joined together. A channel (**Figure 16, Item 9**) at the bottom of the mapboard assembly holds pens or markers.

Support Straps. The support straps (**Figure 16, Item 10**) are constructed of 1-inch wide nylon webbing. The straps are 10 inches long. A grommet is located at one end through which a hook is inserted. Support straps are used to suspend mapboards from the frame. Ten support straps are issued with each MCPS.

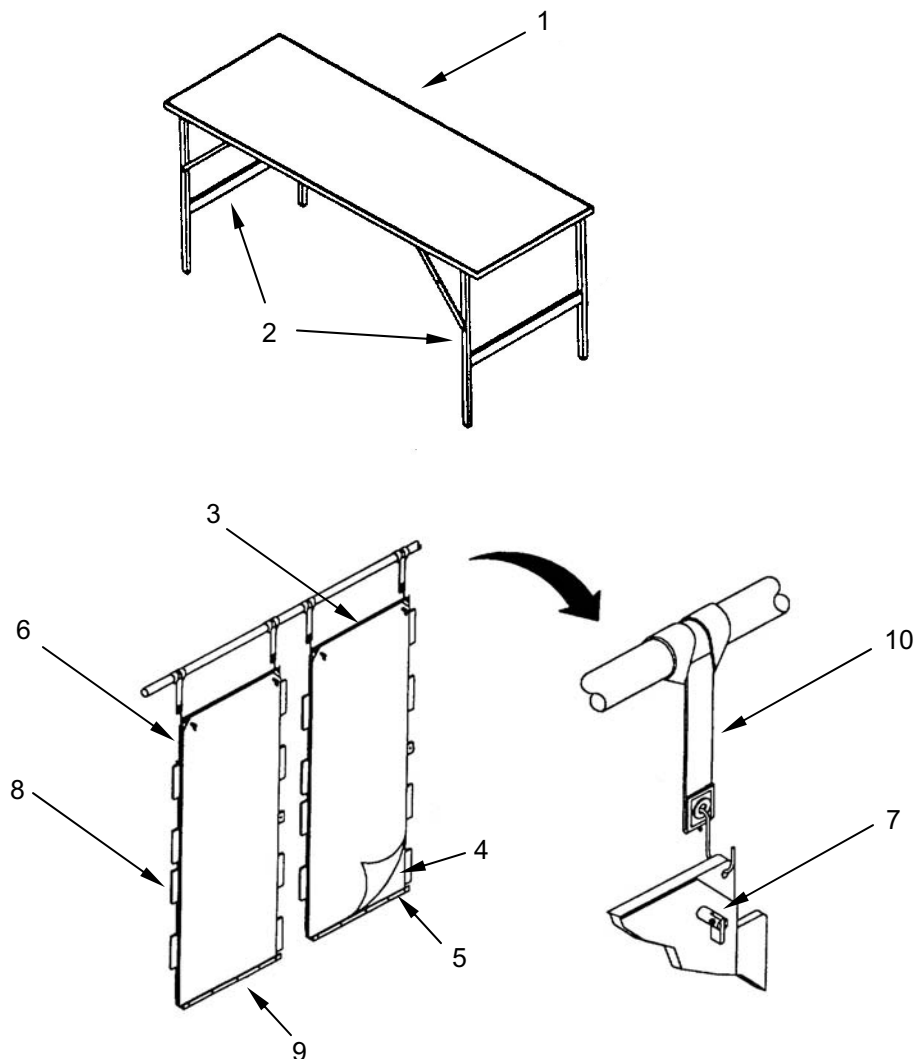

Figure 16. Table and Mapboard.

Light Set. The light set (**Figure 17, Item 1**) consists of two individual lights which are suspended from straps (**Figure 17, Item 2**) and connected together electrically. Each light consists of a fluorescent lamp mounted in a reinforced plastic tube (**Figure 17, Item 3**) with a molded cap and cable assembly at each end. The cap (**Figure 17, Item 4**) with the male power cable mounts an On/Off switch. A light filter is included with each light for use in areas where light discipline is required.

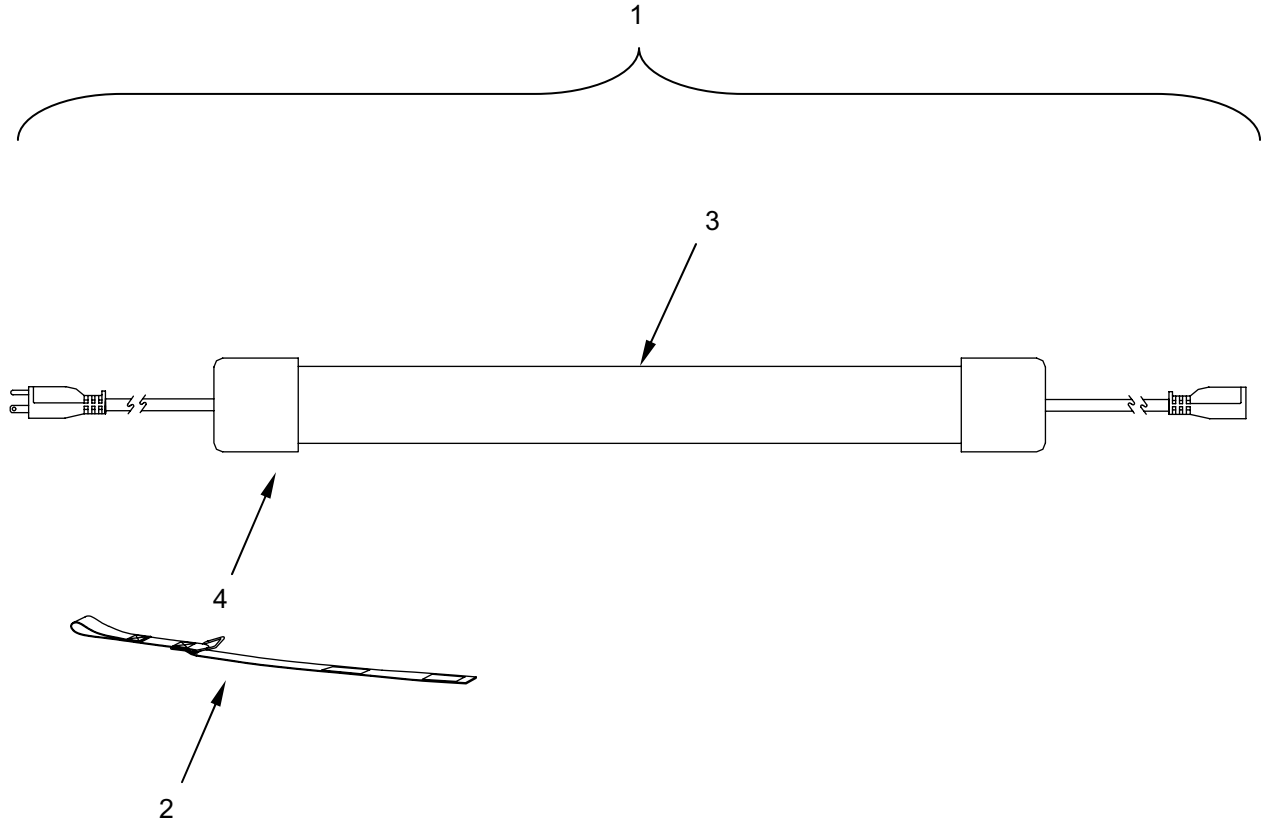

Figure 17. Light Set.

Frame Transport Bag. The frame transport bag (**Figure 18, Item 1**) is constructed of a coated cloth material. When loaded, it is approximately 70 inches long, 19 inches wide and 9 inches high. Four quick disconnect male fasteners are located along one side about 15 ½ inches apart. Corresponding quick disconnect female fasteners are located on the opposite side. Both ends are secured with one each additional quick disconnect male/female fastener, as well as 2-inch strips of hook and pile fasteners. One carrying handle is located at each end of the bag. A label with abbreviated frame set up instructions is sewn to the inside of the bag. An identification label is also sewn to the inside of the bag. Additionally, "FRAME BAG" and a weight limit warning are stenciled onto the side. One frame transport bag is issued with each MCPS.

Fabric Transport Bag. The fabric transport bag (**Figure 18, Item 2**) is constructed of a coated cloth material. When loaded, it is approximately 36 inches long, 26 inches wide and 15 inches high. Three quick disconnect male fasteners are located along one side approximately 14 inches apart. Corresponding quick disconnect female fasteners are located on the opposite side. Both ends are secured with one each additional quick disconnect male/female fastener, as well as 2-inch strips of hook and pile fasteners. One carrying handle is located at each end of the bag. An identification label is sewn to the inside of the bag. Additionally, "TENT BAG" and a weight limit warning is stenciled onto the side. Two fabric transport bags are issued with each MCPS.

Tent Pin Container. The tent pin container (**Figure 18, Item 3**) is constructed of a polyester cloth. It is approximately 37 ½ inches long and 15 ½ inches wide. The container is secured with tie straps. One tent pin container is issued with each MCPS.



Figure 18. Transport Bags and Tent Pin Container.

DIFFERENCES BETWEEN MODELS**Type I**

The Type I MCPS is the original MCPS tent system. It is equipped with plain (uninsulated) wall liners only, and does not have provisions to accommodate Space Heater, Convective (SHC) or ECU ducts. The Type I may only be single-line complexed as issued. Door openings on Type I MCPS tents are off-center, and are fitted with a standard TEMPER vestibule.

Type III

The Type III MCPS is fitted with window and plain walls that may accommodate SHC and ASH ducting. A full set of insulated liners is shipped with the tent. An entrance wall with a centrally located door opening may be fitted with a standard TEMPER vestibule, as well as adapted as a bootwall interface for a number of systems.

EQUIPMENT DATA**Table 1. Equipment Data.**

Dimensions	English	Metric
Height at Eaves	7 ft	2.13 m
Height at Ridge	9 ft, 6 in	2.89 m
Length per side	11 ft, 4 ½ in	3.46 m
Frame Transport Bag	70 in x 19 in x 9 in	177.8 cm x 48.26 cm x 22.86 cm
Fabric Transport Bag	36 in x 26 in x 15 in	91.44 cm x 66.04 cm x 38.1 cm
Light Set	75.5 in x 12 ½ in x 7 ½ in	184.15 cm x 31.75 cm x 19.05 cm
Mapboard Assembly (ea)	24 in x 27 ½ in x 21 in	60.96 cm x 69.85 cm x 53.34 cm
Table (ea)	62 in x 25 in x 1 ½ in	157.48 cm x 63.5 cm x 3.81 cm
Weight		
Total System Weight	353 lbs	160.1 kg
Volume and Area		
Total Volume Packed	33 cu ft	0.93 m ³
Total Square Feet Deployed	150 sq ft	13.9 m ²

END OF WORK PACKAGE

**OPERATOR, UNIT, AND DIRECT SUPPORT MAINTENANCE
MODULAR COMMAND POST SYSTEM (MCPS), SMALL
THEORY OF OPERATION**

GENERAL

The MCPS is part of the Standard Integrated Command Post System (SICPS). It provides environmental protection to support command, control, communications and intelligence operations.

Frame Assembly

The basic frame assembly is constructed of aluminum alloy tubing that is assembled with a series of fittings and joints. Two end wall assemblies (**Figure 1, Item 1**) connect to a center wall assembly (**Figure 1, Item 2**) with eave (**Figure 1, Item 3**) and ridge (**Figure 1, Item 4**) purlins that snap together. Cable assemblies (**Figure 1, Item 5**) allow the frame to support roof loads by connecting the sides of the MCPS together. The telescoping feature of the leg assemblies (**Figure 1, Item 6**) facilitates the raising of the frame assembly one side at a time, and permits the MCPS to be set up on sloping terrain. Two additional poles (**Figure 1, Item 7**) are used to support the vestibule. Tent frame brackets are used to ensure proper placement of frame components when complexing tents.

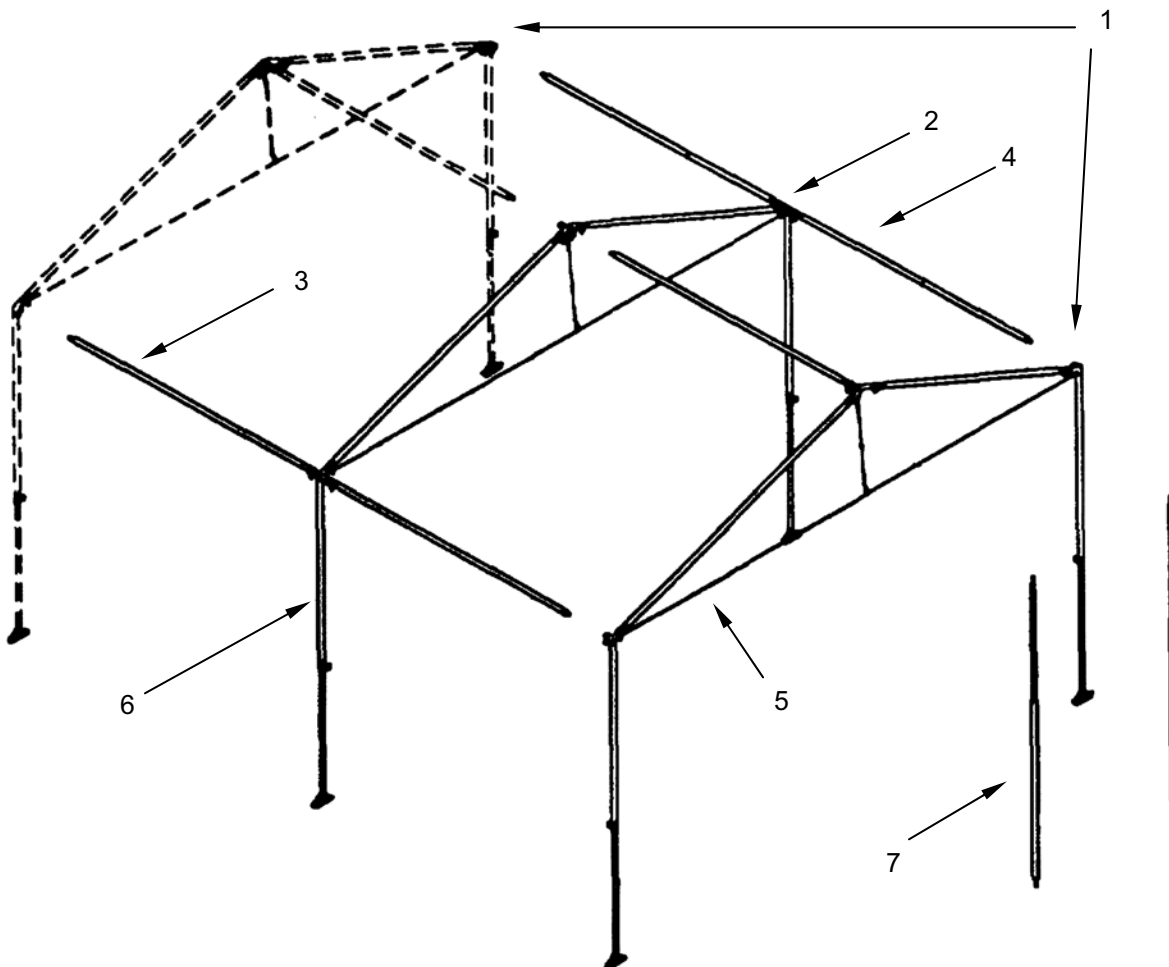

Figure 1. Frame Assembly.

Fabric Sections

The MCPS utilizes four exterior fabric wall sections (**Figure 2, Item 1**) of similar dimensions that can be arranged as desired. The wall sections are suspended from the roof cap (**Figure 2, Item 2**) with a series of quick disconnect male/female fasteners, as well as strips of hook and pile fasteners. Light colored wall liners (**Figure 2, Item 3**), of similar dimensions, aide in light diffusion and provide insulation. They can also be used as outside walls during warm weather and during daylight. The entrance way wall liners are also used on the window walls. A light colored floor (**Figure 2, Item 4**) attaches to the walls with quick disconnect male and female fasteners. The roof cap contains two ventilation vents and a stove pipe opening (**Figure 2, Item 5**). A covered entry way (**Figure 2, Item 6**) that is an integral part of the entrance way wall provides environmental protection and allows maintenance of light discipline. Walls are available with or without ECU/SHC ducts. When two or more tents are complexed a rain gutter connects between two tents to help rain water run off. Insulated wall liners are available for each individual wall style for use in extreme operating conditions.

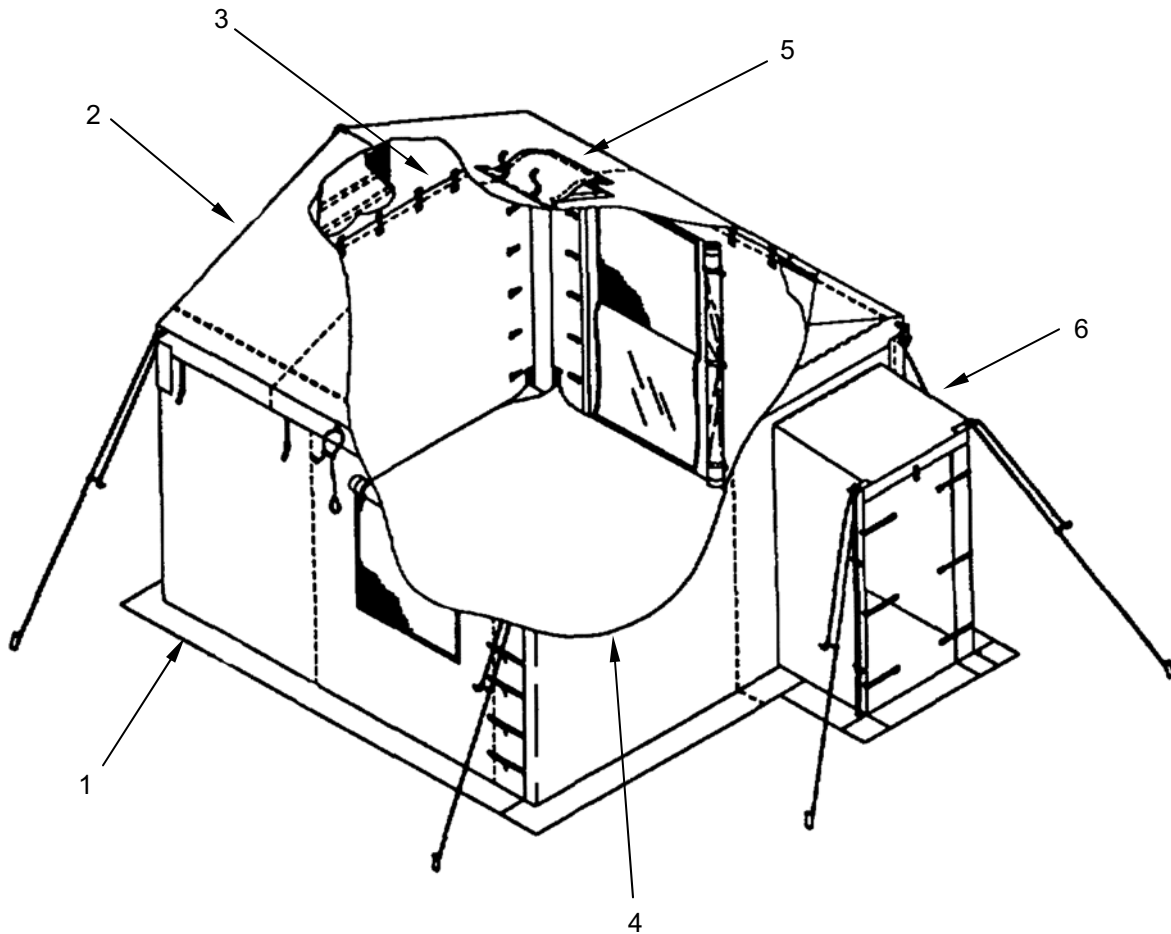

Figure 2. Fabric Sections (Type I Shown).

Light Assembly

The light set is filtered and screened for electro-magnetic interference reduction. The individual lights (**Figure 3, Item 1**) are totally enclosed and waterproof. The light set will operate on 110 Volt AC, 50/60 Hertz. The lights are suspended from the purlins with straps, and will operate in a series (up to 12) even if one light fails. A polycarbonate filter is fitted to each light and reduces light intensity during blackout conditions. The filter also aids in rapid night vision adaptation when exiting during darkness. The filter can be rotated to aim a strip of unfiltered light onto mapboards or other desired areas.

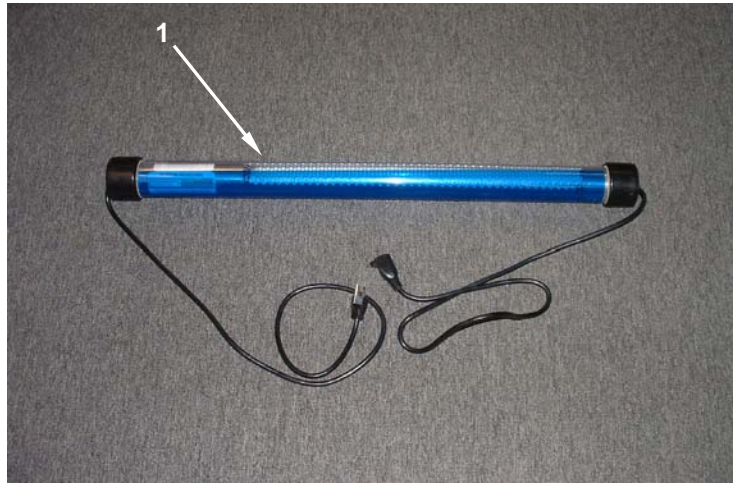

Figure 3. Light Assembly.

Mapboard Assembly

Two or more of the four mapboards (**Figure 4, Item 1**) furnished with the MCPS can be joined together by aligning the complexers (**Figure 4, Item 2**) of one or more mapboard assemblies and snapping them together. The mapboards are only provided with the Type I MCPS.

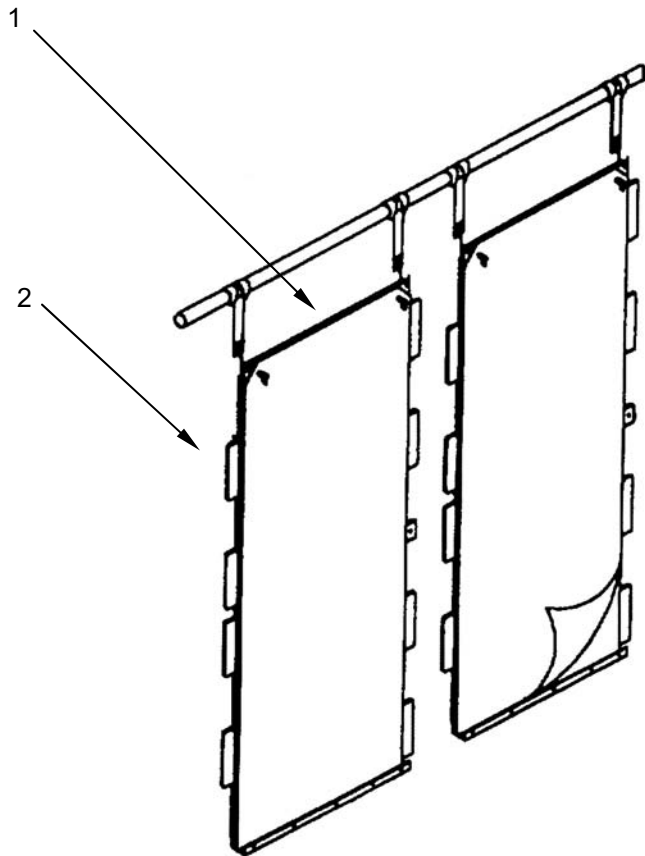

Figure 4. Mapboard Assembly.

Bootwalls

Bootwalls (**Figure 5, Item 1**) are available to interface the MCPS with the M577, the RWS, and the TEMPER tent system. Bootwalls are used in place of a standard wall section, and are fitted with a draping boot to provide a weathertight connection. The bootwall and fabric section are not supplied with the MCPS and must be ordered separately.



Figure 5. Bootwalls.

Complexing

MCPS tents may be complexed in any number of ways using the rain gutters to connect the complexed tents. When tents are complexed, adjoining walls are not fitted, but plain wall liners may be used to partition off areas of the complexed tent for privacy.

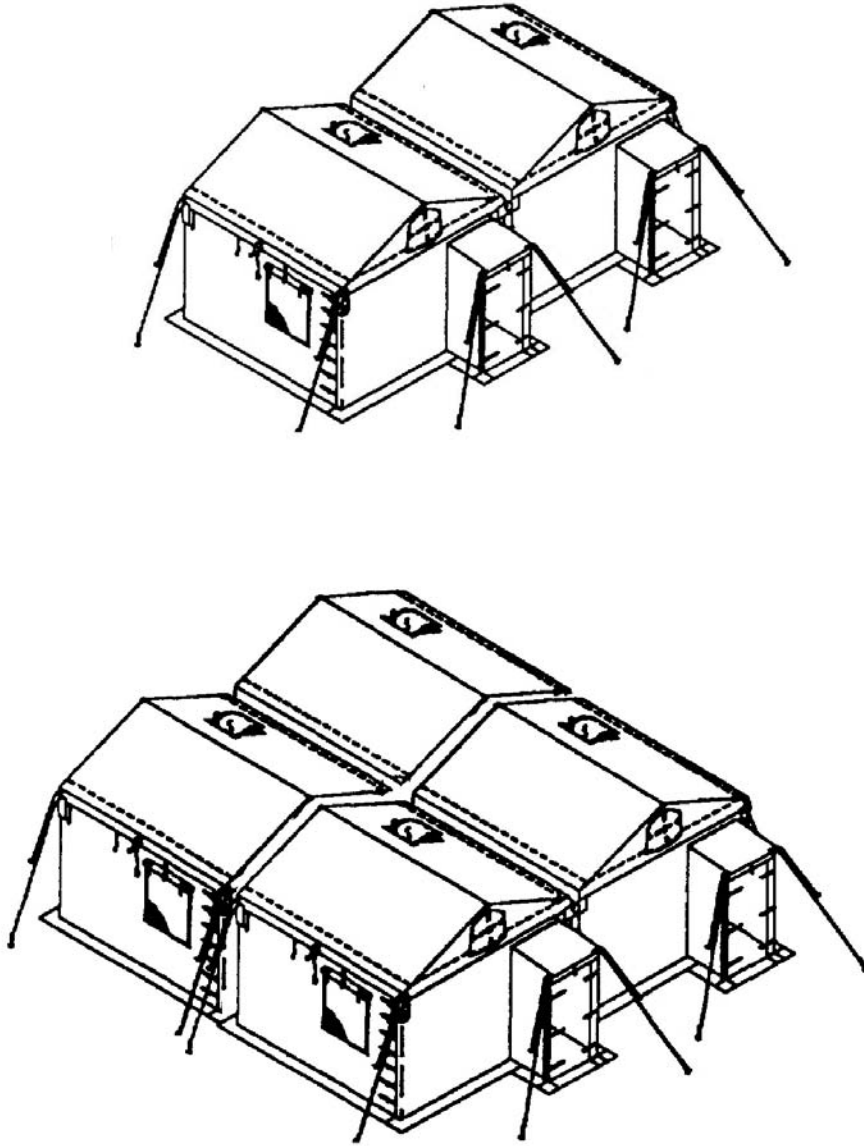

Figure 6. Complexing.

END OF WORK PACKAGE

CHAPTER 2
OPERATOR INSTRUCTIONS
FOR
MODULAR COMMAND POST SYSTEM (MCPS), SMALL

**OPERATOR, UNIT, AND DIRECT SUPPORT MAINTENANCE
MODULAR COMMAND POST SYSTEM (MCPS), SMALL
DESCRIPTION AND USE OF OPERATOR CONTROLS AND INDICATORS**

GENERAL

The MCPS has been designed for use in forward combat areas and has relatively few moving parts.

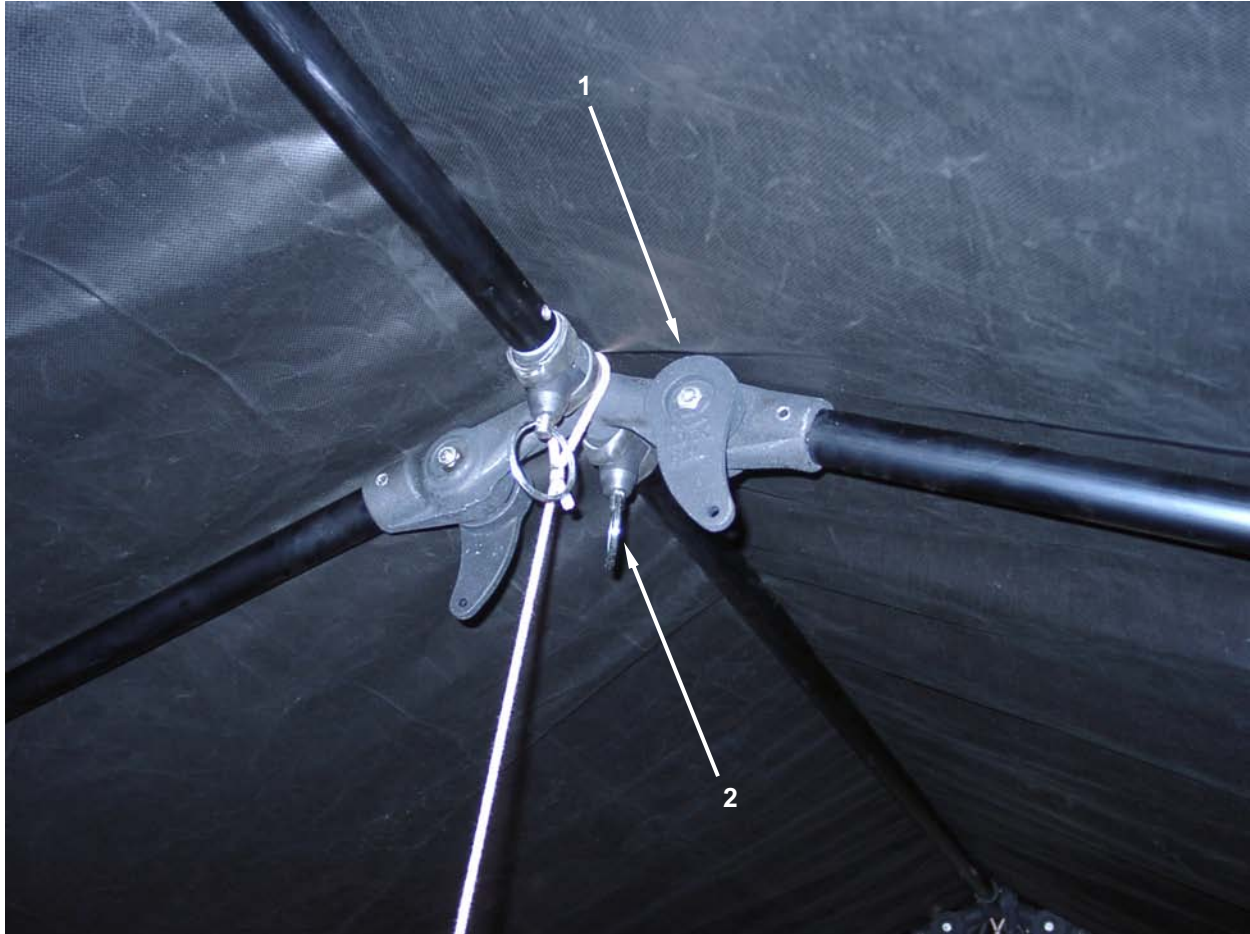

Figure 1. Frame Controls.

Key	Control or Indicator	Function
1	Handle	Allows movement of purlins.
2	Release	Allows disassembly of purlins from frame assemblies.



Figure 2. Light Controls.

Key	Control or Indicator	Function
1	On/Off Switch	Turns lamp in light on or off.

END OF WORK PACKAGE

**OPERATOR, UNIT, AND DIRECT SUPPORT MAINTENANCE
MODULAR COMMAND POST SYSTEM (MCPS), SMALL
OPERATION UNDER USUAL CONDITIONS**

INITIAL SETUP**Personnel Required**

Two

References

WP 0010, WP 0047

TM 10-5410-230-13

SITING REQUIREMENTS

When selecting a site on which to set up the MCPS:

- Select a level, easily defended position.
- Ensure there is sufficient space to complex the needed number of Modular Command Post Systems as well as sufficient access for tactical vehicles.
- If possible, the area should be sheltered from high winds.
- Clear area of all rocks and underbrush.
- Dig a drainage ditch around the area.

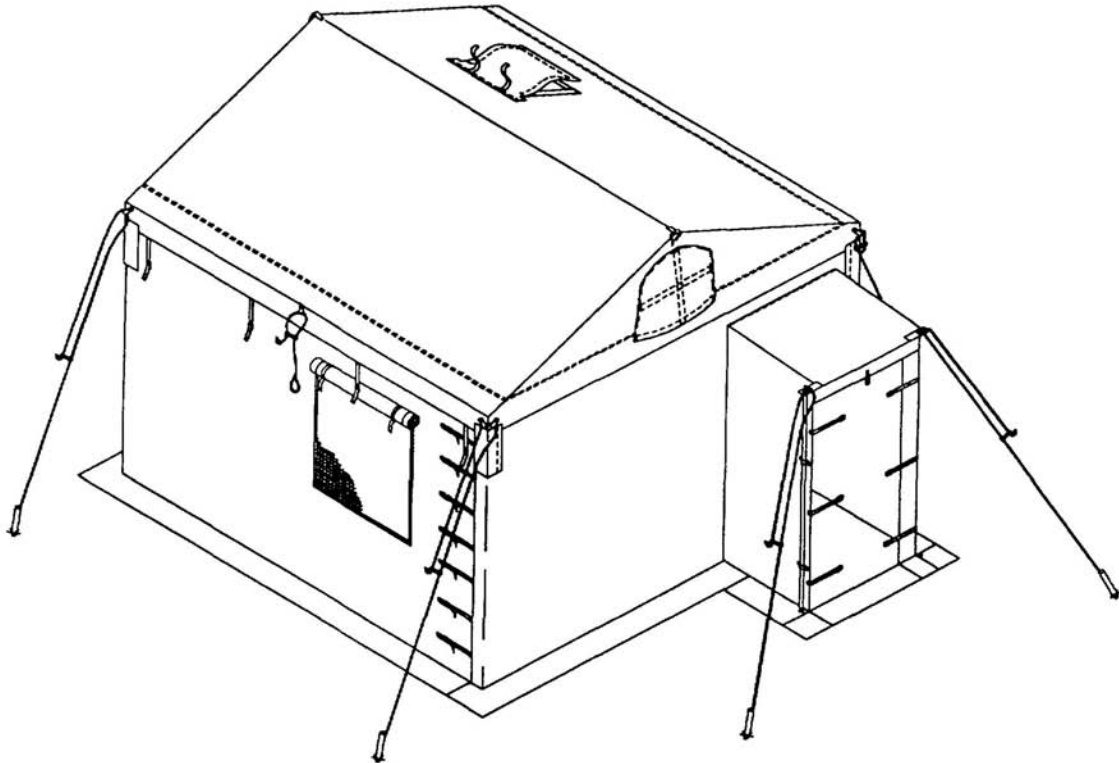

Figure 1. Modular Command Post System (MCPS), Small (Type I Shown).

ASSEMBLY AND PREPARATION FOR USE

Unpacking and Inspection

All MCPS components are packaged in reusable shipping crates. Unpack crates/transport bags and visually inspect their contents. Make sure that everything is there, including end items and basic issue items as listed in work package 0047. Also refer to work package 0010, PMCS, for inspection procedures. Do not destroy shipping crates. Put the crates away for later use.

Partial Frame Setup

WARNING



When handling tent frame, do not grasp the frame near the frame joints. Failure to do so can result in personnel injury to hands and fingers. Failure to follow tie down and staking instructions may result in possible injury to personnel and damage to equipment.

Erecting the tent frame requires at least two persons. Failure to observe this safety precaution may result in serious injury or death to personnel.

CAUTION

Do not stand or walk on tent frame assemblies. They can be damaged by misuse. When handling tent frame do not twist or force the frame. Unfold frame sections on the ground. Do not pick up the frame to unfold it, as this will cause binding of the fitting assemblies and damage to the frame can result.

1. Unpack the three frame pieces. There are two identical end wall frame assemblies (**Figure 2, Item 1**) and one center wall frame assembly (**Figure 2, Item 2**).

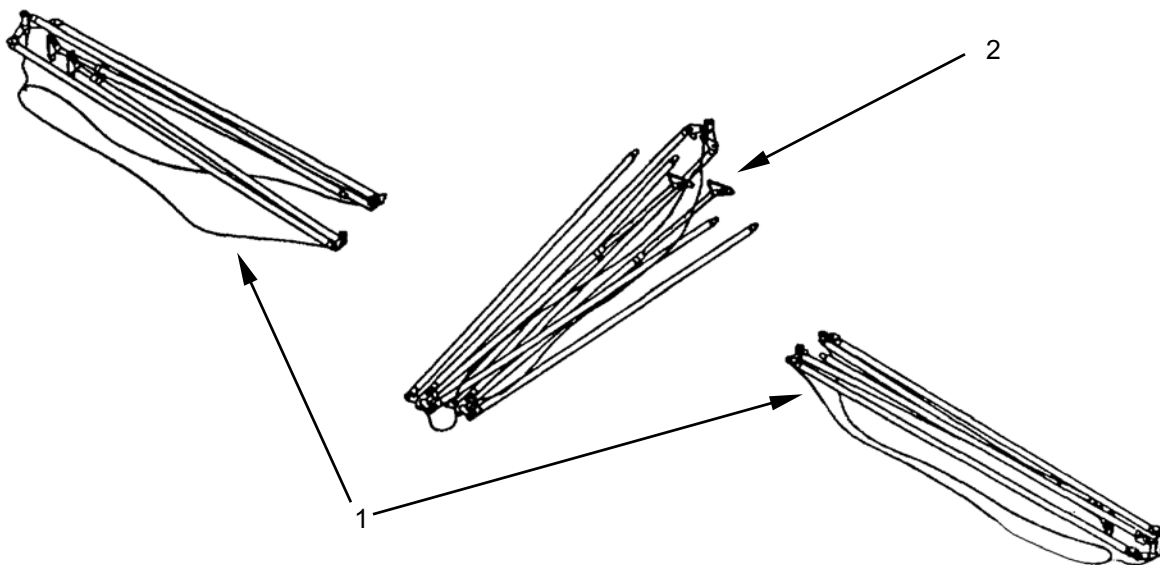

Figure 2. Unpack the Three Frame Pieces.

2. Lay the three frame assemblies on the ground. Put the center wall frame assembly (**Figure 3, Item 2**) in between the two end wall frame assemblies (**Figure 3, Item 1**). Make sure the left hand purlin (**Figure 3, Item 3**) on each end wall frame assembly is on top.
3. Unfold the rafter assemblies (**Figure 3, Item 4**) on each frame assembly away from the center as far as they will go. Each of the three frame assemblies should form a "V". Do not unfold the legs at this time.
4. Lock the rafter assemblies (**Figure 3, Item 4**) into place at the peak fitting (**Figure 3, Item 5**) by engaging the teeth and turning the handles (**Figure 3, Item 6**) on each fitting downwards until they are tight, and the rafter assemblies (**Figure 3, Item 4**) cannot move. Repeat this process for each of the three frame pieces.

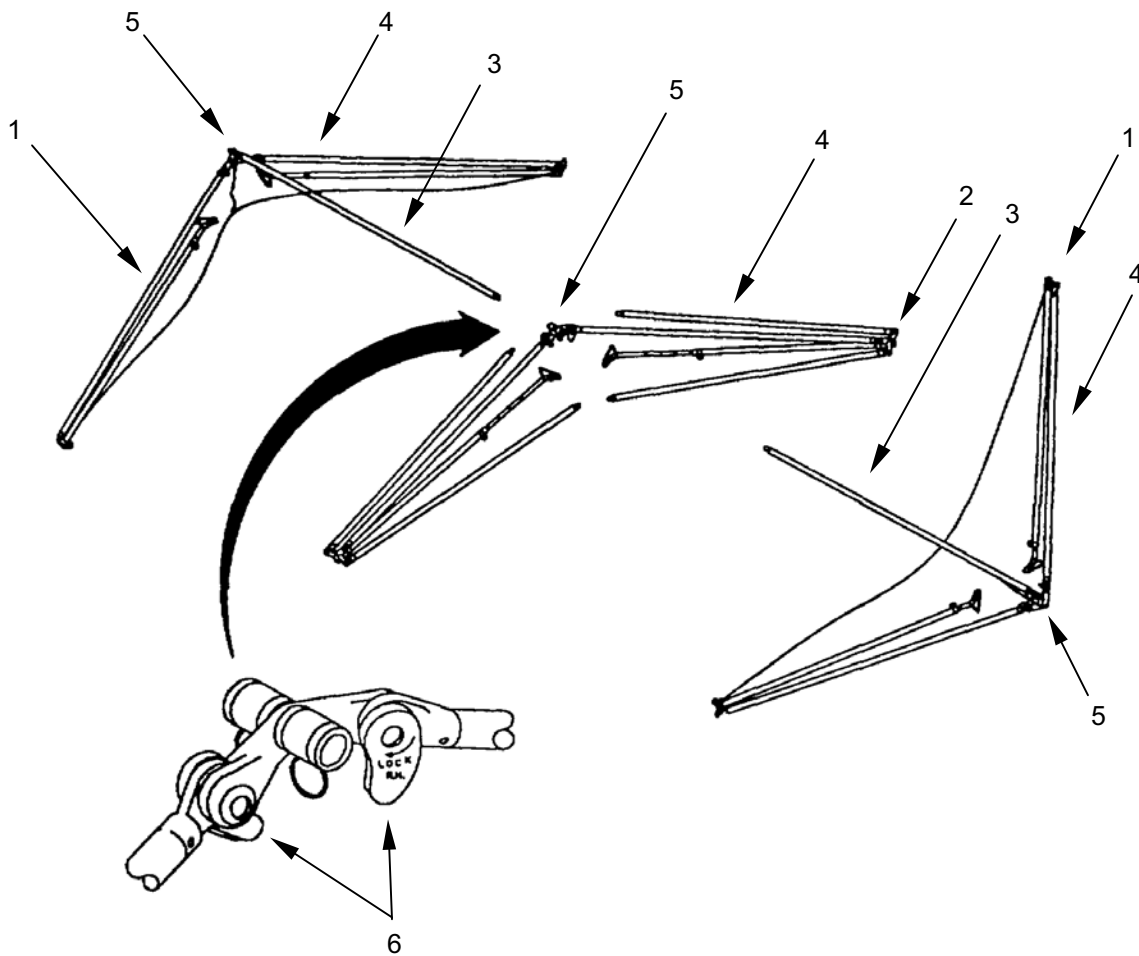

Figure 3. Assemble the Rafters.

5. Unfold the four left hand (**Figure 4, Item 7**) and right hand (**Figure 4, Item 8**) purlins on the center wall frame assembly (**Figure 4, Item 2**). Lock these into place by engaging the teeth and turning the handles (**Figure 4, Item 6**) on the midwall fitting assemblies (**Figure 4, Item 9**) towards the center. When viewed from above, this piece would appear in the shape of an "H".
6. Rotate the left hand purlins (**Figure 4, Item 7**) on the center of each end wall frame assembly (**Figure 4, Item 1**) so they are pointing into the air, and lock into place with the handle (**Figure 4, Item 6**) on the end peak fitting (**Figure 4, Item 5**).
7. Rotate one of the end wall frame assemblies (**Figure 4, Item 1**) so the connector end (**Figure 4, Item 10**) of the left hand purlin (**Figure 4, Item 7**) is facing the peak center joint (**Figure 4, Item 5**) of the center wall frame assembly (**Figure 4, Item 2**). Insert the connector (**Figure 4, Item 10**) into the socket (**Figure 4, Item 11**). It should lock into place. Repeat this procedure with the other end wall frame assembly.

NOTE

If the connector does not fit in easily, do not force it. Pull the pin and wiggle the connector into the socket.

8. Connect the left hand (**Figure 4, Item 7**) and right hand (**Figure 4, Item 8**) purlins on the center wall frame assembly (**Figure 4, Item 2**) to the sockets (**Figure 4, Item 11**) on the end wall corner fittings (**Figure 4, Item 12**) of the end wall frame assemblies (**Figure 4, Item 1**). Lock all four purlins in the same manner.

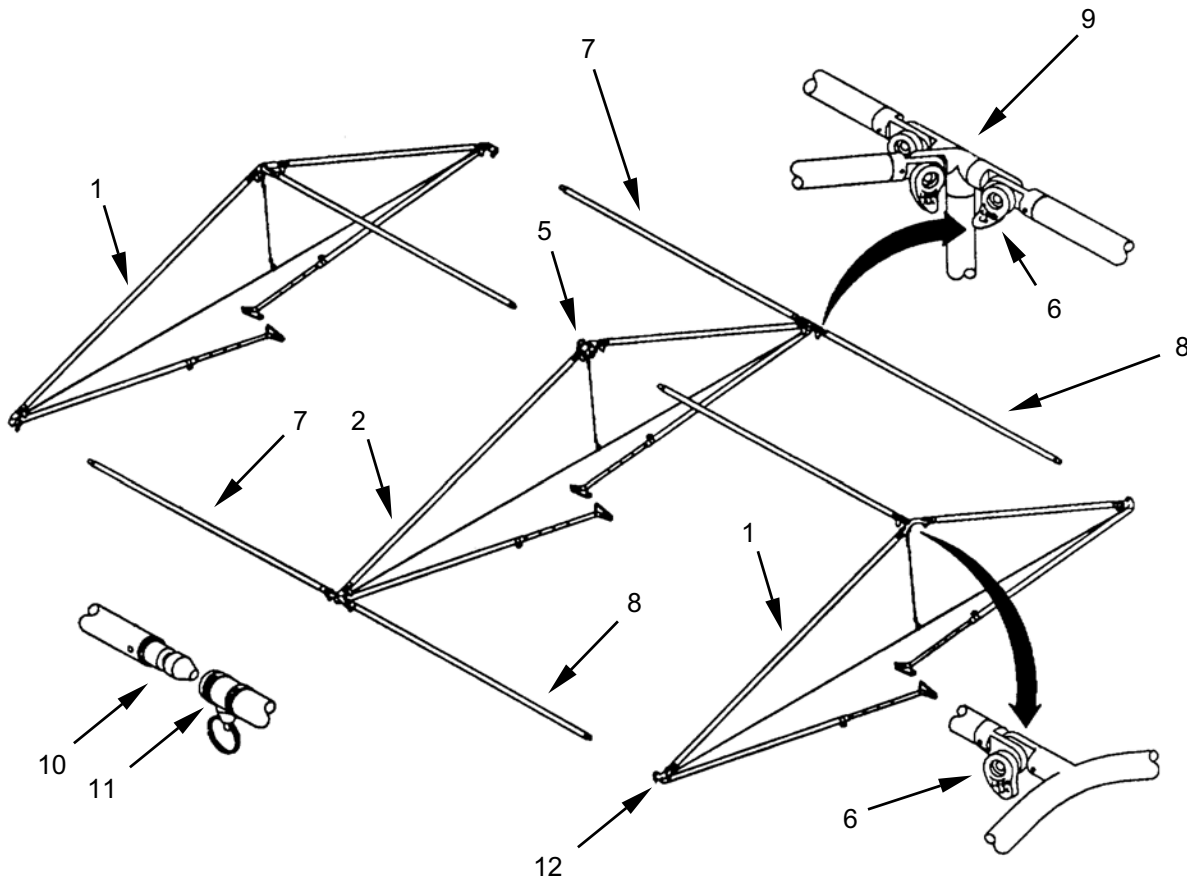

Figure 4. Connecting the Frame Sections.

END OF TASK

Install the Roof Cap Liner

NOTE

The roof cap liner must be installed even if no other liners are intended for immediate use. The roof cap liner cannot be installed after the tent is erected.

1. Place the hook and pile fastener end of two light support straps (**Figure 5, Item 1**) over the ridge purlins (**Figure 5, Item 2**) and draw through the loop end of the strap. Space straps 3 feet apart. Pull tight around the ridge purlin.

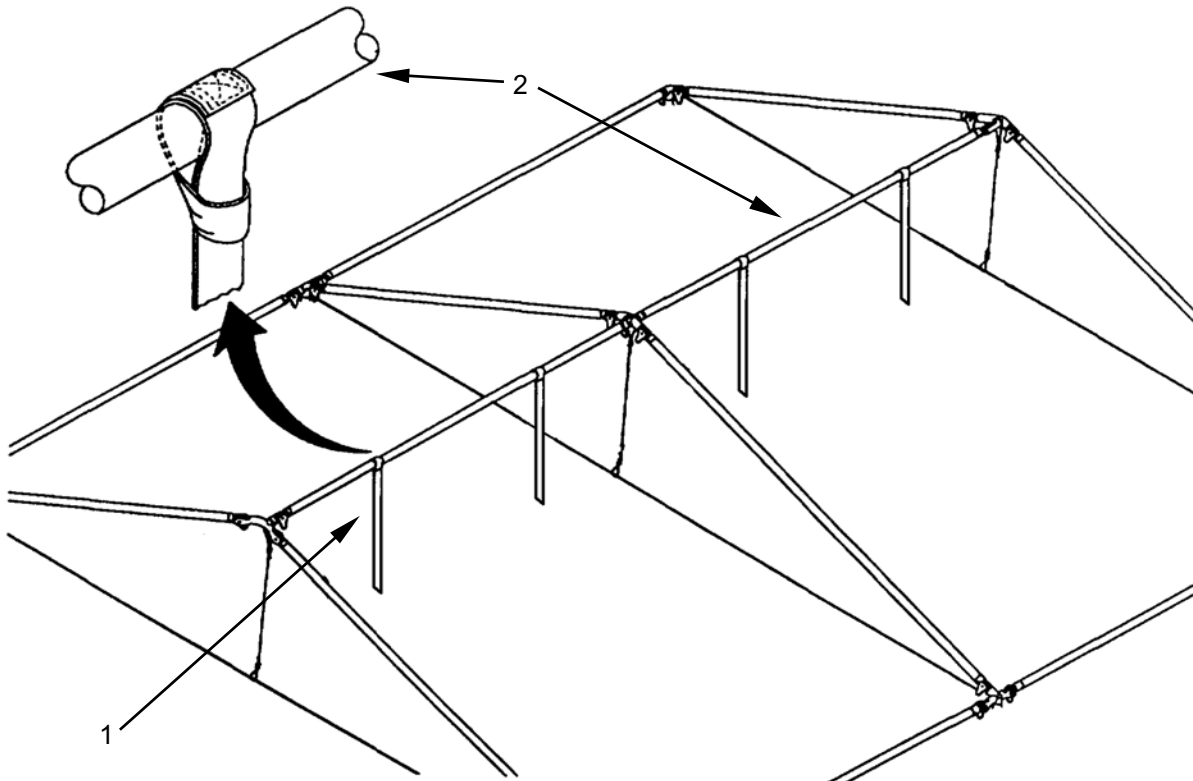

Figure 5. Install the Light Support Straps.

2. Locate the roof cap liner (**Figure 6, Item 3**) and insert it under the ridge poles (**Figure 6, Item 4**). Make sure the ridge pole straps are facing the ridge pole.
3. Locate the long slit (**Figure 6, Item 5**) in the center of the roof cap liner (**Figure 6, Item 3**). Release the hook and pile fasteners from the slit, and open the slit.
4. Fit the long slit (**Figure 6, Item 5**) around the elastic cord (**Figure 6, Item 6**) supporting the cable (**Figure 6, Item 7**).
5. Close the slit (**Figure 6, Item 5**) around the elastic cord (**Figure 6, Item 6**), and secure with the hook and pile fastener. Ensure that the slit is closed over the cable (**Figure 6, Item 7**) – you will not be able to see the cable when the slit has been closed.

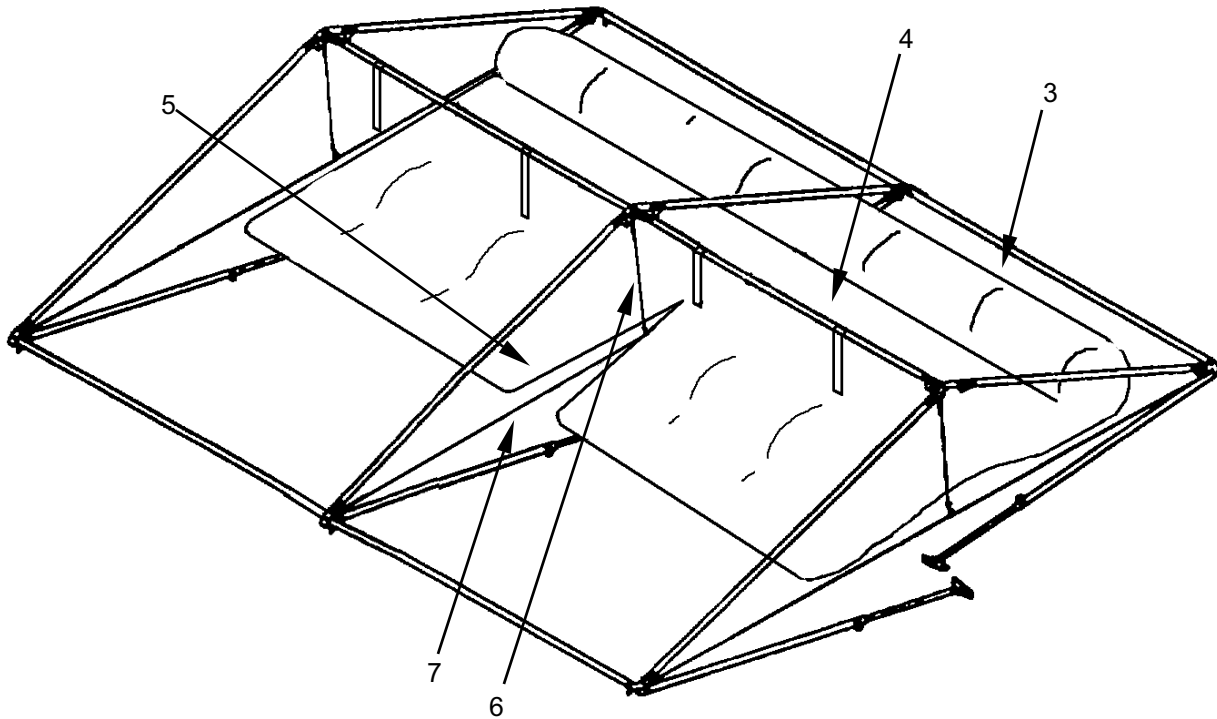

Figure 6. Install the Roof Cap Liner.

6. Attach the roof cap liner (**Figure 7, Item 3**) to the ridge pole (**Figure 7, Item 4**) using the five straps (**Figure 7, Item 8**). The liner will hang approximately 6 inches from the ridge poles.
7. Insert the light straps (**Figure 7, Item 1**) through the slits in the roof cap liner (**Figure 7, Item 3**).
8. Secure the center roof pole sleeves (**Figure 7, Item 9**) with hook and pile fasteners.
9. Attach the roof cap liner to the roof poles with the hook and pile fasteners (**Figure 7, Item 10**). Make sure the liner is positioned between the ridge pole (**Figure 7, Item 4**) and the cables.

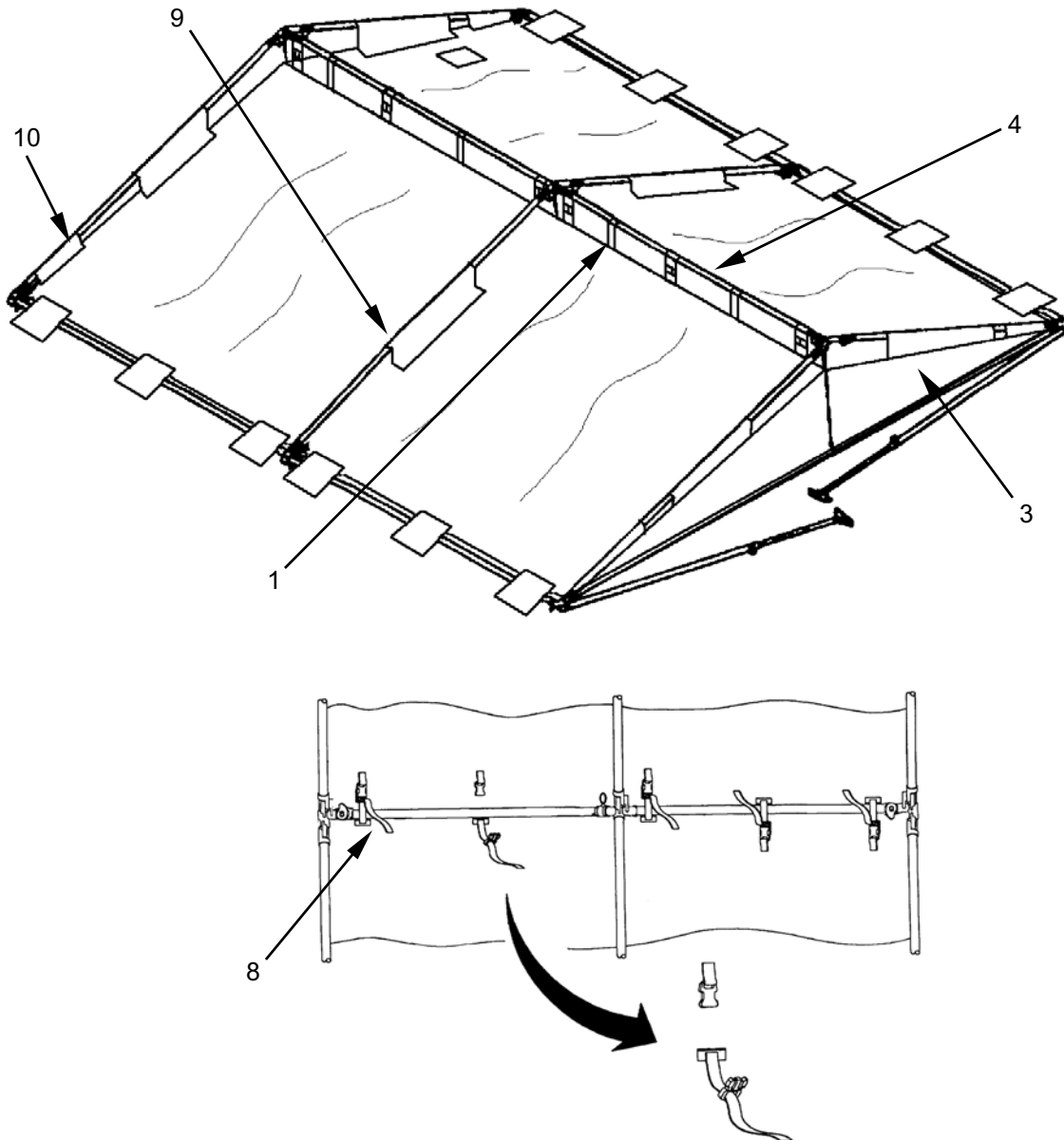

Figure 7. Secure the Roof Cap Liner.

END OF TASK

Roof Cap Installation

NOTE

Do not raise the legs until the roof cap fabric is installed.

1. Locate the folded up roof cap (**Figure 8, Item 1**) and unfold it so that the crease between the folds is up and flat side is down. Do not unroll it at this time.
2. Position the rolled up roof cap (**Figure 8, Item 1**) exactly over the center wall frame rafter assemblies (**Figure 8, Item 2**).
3. Unroll one half of the roof cap (**Figure 8, Item 1**).

NOTE

If the MCPS is to be heated with a space heater, locate the stove pipe opening towards the plain wall end of the tent, and ensure that the chimney flap on both the roof cap liner and the roof cap have been opened.

4. Stretch the corners of the roof cap (**Figure 8, Item 1**) over the corners of an end wall frame assembly (**Figure 8, Item 3**). Repeat steps 3 and 4 with the other half of the roof cap.

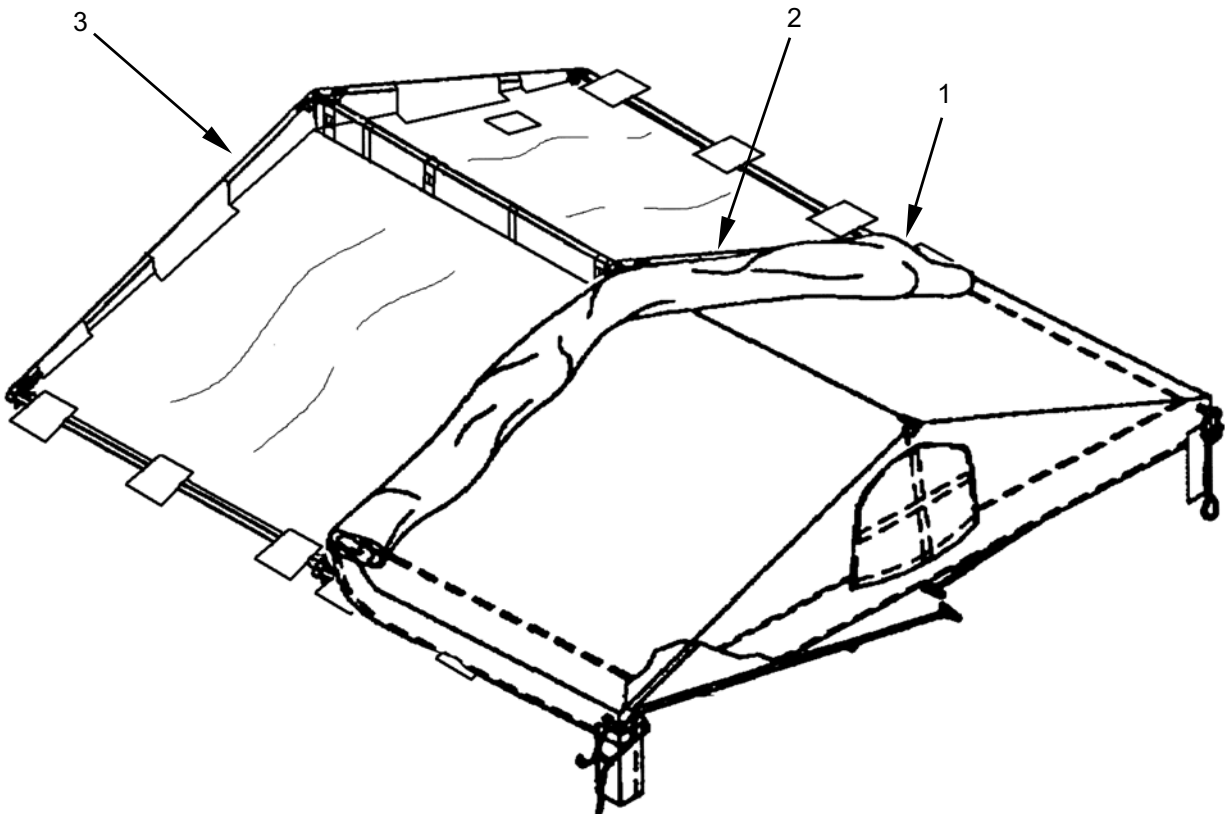

Figure 8. Roof Cap Installation.

END OF TASK

Unfolding the Frame Legs

1. Choose one of the sides with three legs (**Figure 9, Item 1**), and lift the frame assembly up at the two corners and rotate the legs out until they stop.
2. Lock the legs (**Figure 9, Item 1**) into position by engaging the teeth and turning the handles (**Figure 9, Item 2**) on the end wall fittings (**Figure 9, Item 3**) downwards until tight. Repeat this procedure with the legs on the center wall frame assembly.
3. Repeat this process on the other side.
4. Attach the roof cap liner (**Figure 9, Item 4**) to the side purlins (**Figure 9, Item 5**) using the hook and pile fasteners (**Figure 9, Item 6**).

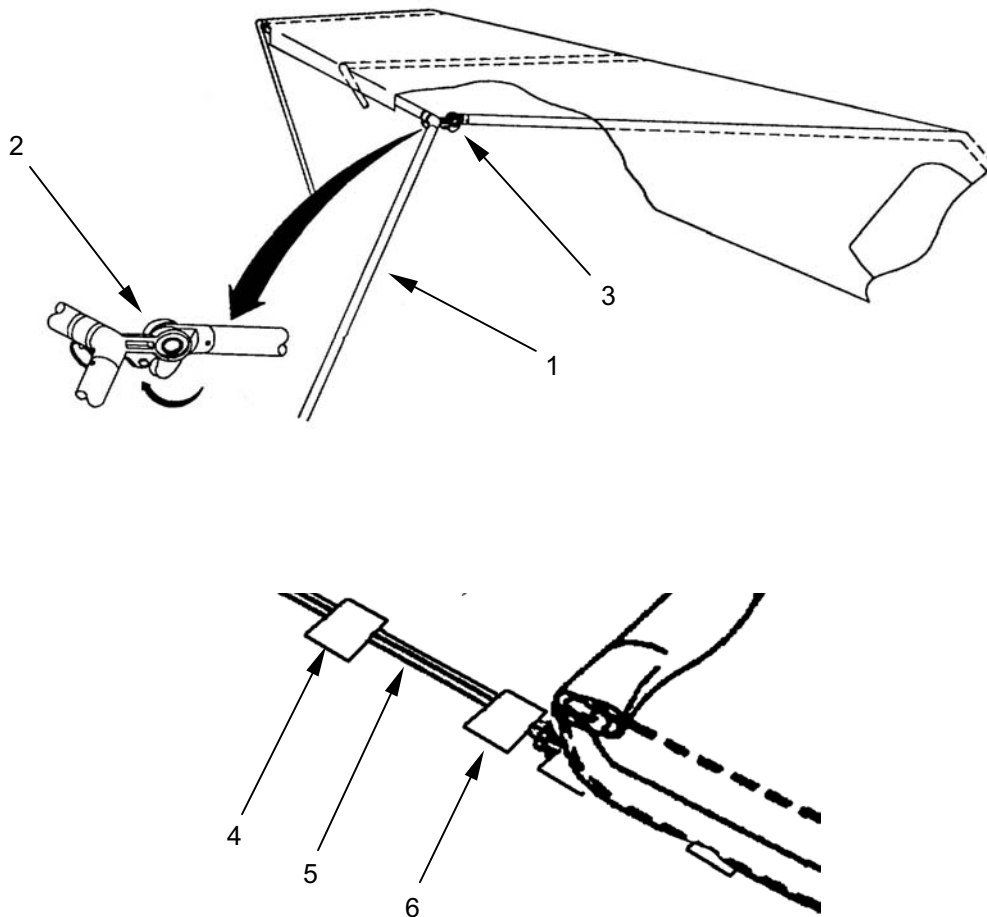

Figure 9. Unfolding the Frame Legs.

5. Slide tent line slips (**Figure 10, Item 7**) halfway along tent lines (**Figure 10, Item 8**). Position the tent lines at a 120 degree angle at the four corners of the roof cap (**Figure 10, Item 9**).
6. Without adjusting the tent line slips (**Figure 10, Item 7**), extend the tent lines (**Figure 10, Item 8**) and drive a wooden tent pin (**Figure 10, Item 10**) through each loop, tilted at a 15 degree angle towards the tent. This will assist in controlling the tent for the rest of the assembly process if there is any wind. These four tent lines must be attached to tent pins for the rest of the assembly process.
7. Lay out the floor, light side up, inside the perimeter of the frame. Pull any extra slack to the edges of the tent so that the walking surface is free of wrinkles.

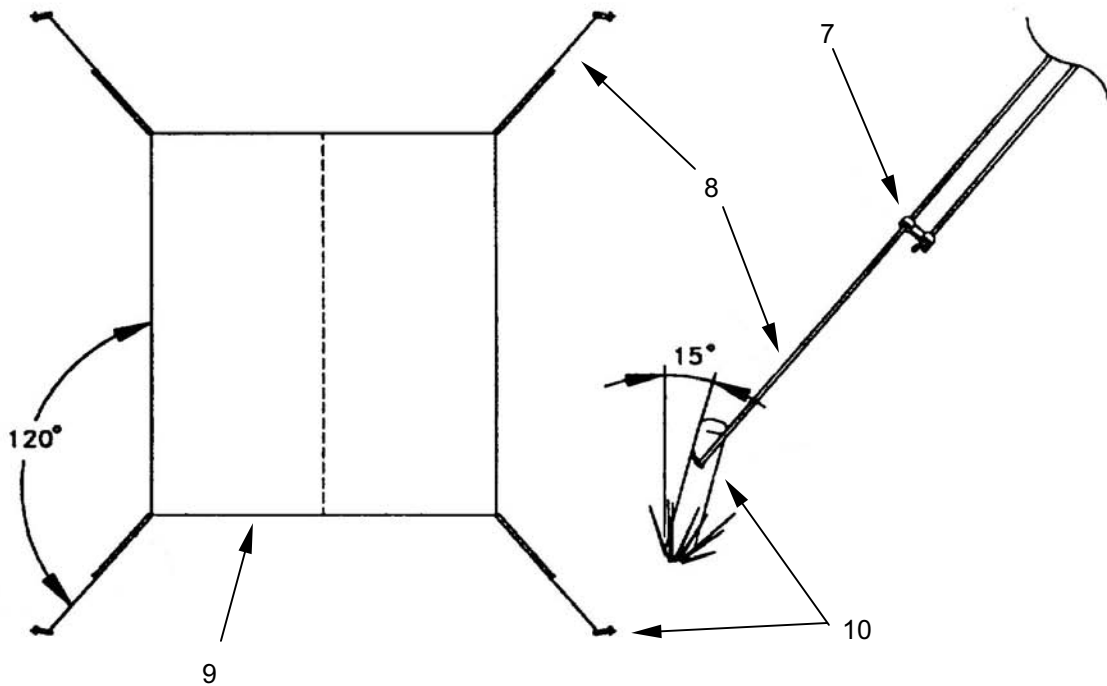

Figure 10. Staking Tent lines.

END OF TASK

Anchoring the Roof Cap

1. Release the buckles (**Figure 11, Item 1**) on the roof cap (**Figure 11, Item 2**) and refasten them around the purlins (**Figure 11, Item 3**), so that the straps (**Figure 11, Item 4**) hold the sides of the roof cap centered over the frame.
2. Pull straps (**Figure 11, Item 4**) tight to eliminate any sag in the roof cap (**Figure 11, Item 2**). Loosen the tent lines on the roof cap.

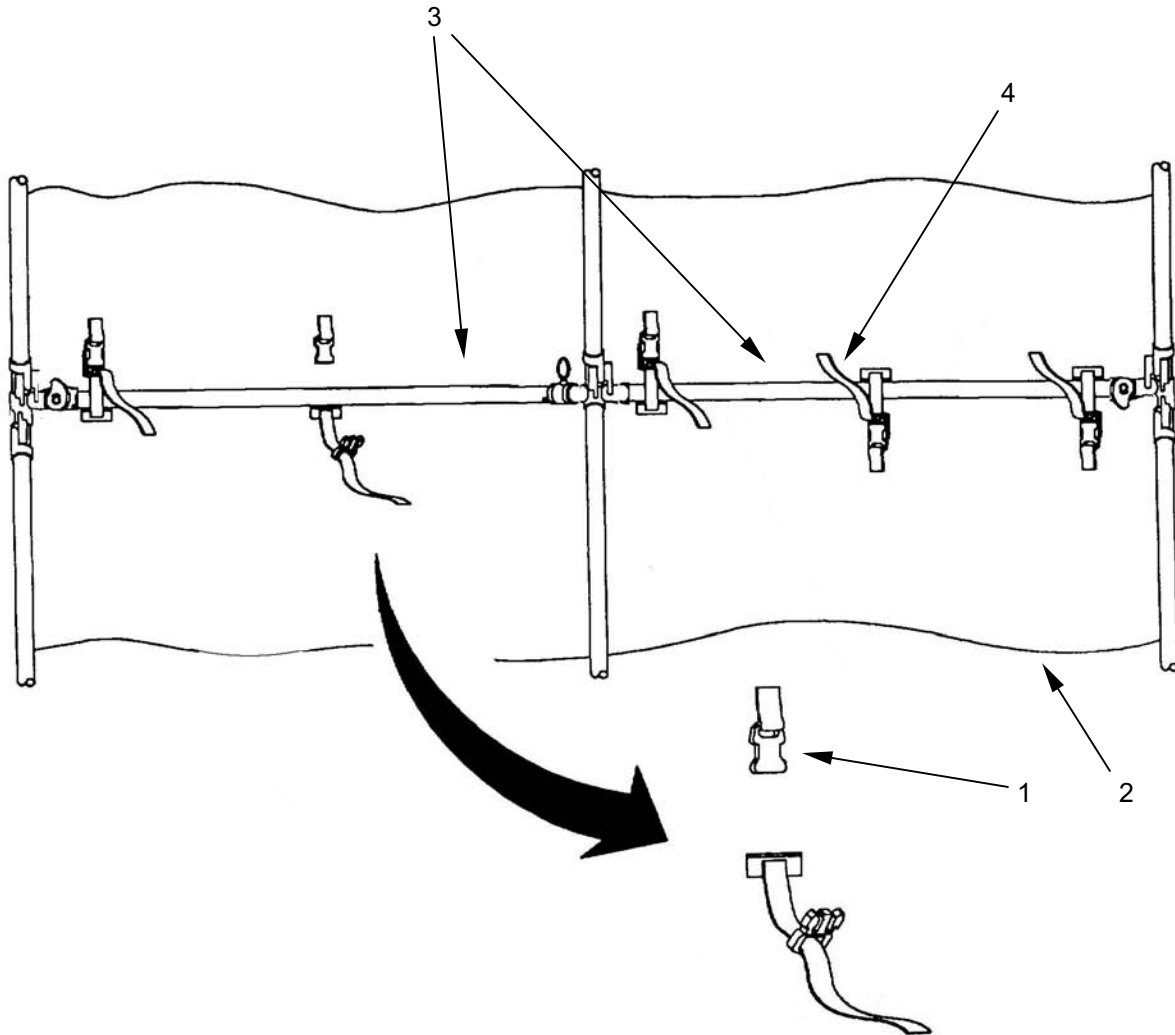

Figure 11. Anchoring the Roof Cap.

END OF TASK

Light Set Installation

WARNING



Install the light set before raising the tent to its full height. This will avoid unsafe working conditions resulting from attempts to install the lights at full tent height.

CAUTION

To prevent damage, leave lights in a secure location until ready to install.

1. Wrap the hook and pile fastener end of the strap (**Figure 12, Item 1**) around the light (**Figure 12, Item 2**) so that the pile fastener faces away from the fixture. Draw the strap through the "D" ring (**Figure 12, Item 3**). Press the hook and pile fastener to secure.
2. Repeat for second light (**Figure 12, Item 2**), ensuring that male and female electrical connectors are facing each other.
3. Connect the female electrical connector (**Figure 12, Item 4**) of one light to the male electrical connector (**Figure 12, Item 5**) of the other light. (A maximum of 12 lights may be joined.)
4. Leave a male electrical connector (**Figure 12, Item 5**) available for connection to the power source.

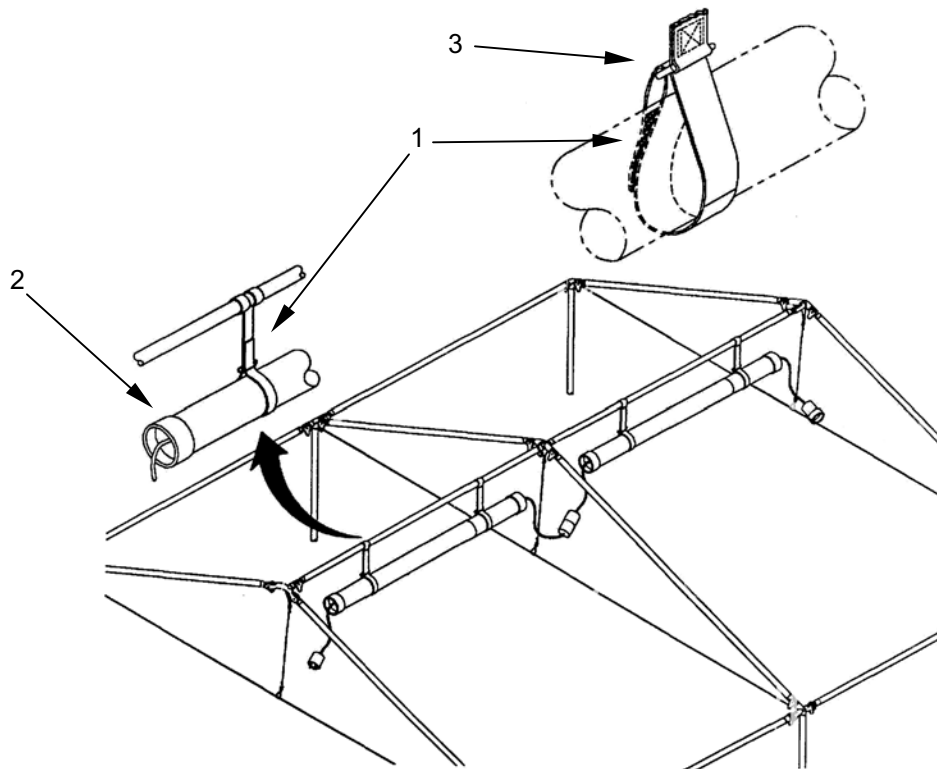

Figure 12. Light Set Installation.

END OF TASK

Extending the Frame to its Full Height

CAUTION

When handling tent frame do not twist or turn. Damage to frame can result.

NOTE

For ease of assembly, the fabric wall sections may be attached before fully extending the height of the frame. This is recommended if the fully extended height of 7 feet makes attaching the walls difficult. Determine the best height for securing the walls and adjust the frame legs accordingly.

1. Loosen all roof cap tent lines (**Figure 13, Item 1**).
2. Choose one of the sides with three legs, and place one person at each corner.
3. Lift the frame straight up off the ground and pull the locking pin (**Figure 13, Item 2**) on the base of the upper leg assemblies (**Figure 13, Item 3**).
4. Raise the upper leg assemblies (**Figure 13, Item 3**) and rotate feet (**Figure 13, Item 4**) on lower leg assemblies (**Figure 13, Item 5**) so that hole for metal tent pin faces outside of tent and the lower leg assemblies lock in place. Intermediate holes are provided for final height adjustments. Four holes should show in the lower leg assemblies. Ensure center leg assembly (**Figure 13, Item 6**) is also locked.
5. Tighten roof cap tent lines (**Figure 13, Item 1**) on the side just extended.
6. Repeat for the opposite side.
7. Stake the frame feet (**Figure 13, Item 4**) down with the metal tent pins and adjust tent lines as required.

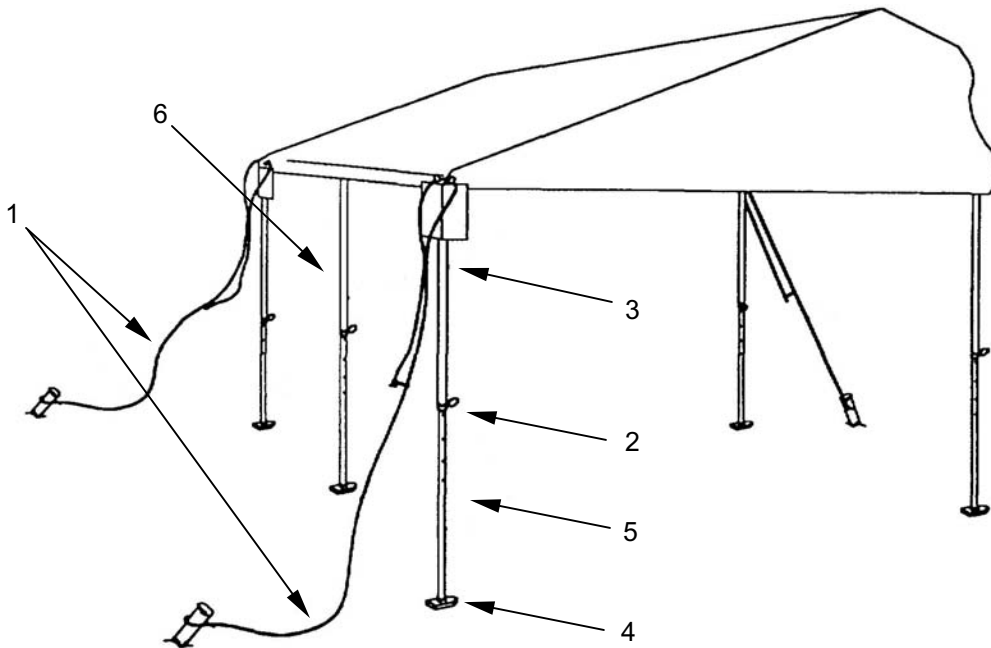

Figure 13. Extending the Frame to its Full Height.

END OF TASK

Complexing the Tents

NOTE

If tents are not to be complexed, go to the section titled, "Fabric Wall Assemblies Installation".

1. Install the gutters (**Figure 14, Item 1**) with the hook and pile fasteners. Make sure the gutters are pitched to provide drainage away from the center of complexed tents, and away from the entrance(s) and any equipment servicing the tent complex, such as ECUs or generators.
2. Connect one side of the rain gutter (**Figure 14, Item 1**) to the inside of the roof (**Figure 14, Item 2**) of one of the adjoining tents the same way that the walls were attached. If tents are to be square complexed, the center gap should be covered by laying a gutter section over the top of the connecting gutter sections.
3. Attach the other side of the rain gutter (**Figure 14, Item 1**) to the other roof cap (**Figure 14, Item 2**).
4. Go outside, lift the corner flaps of the roof cap (**Figure 14, Item 2**) out of the way and fasten the rain gutter flaps (**Figure 14, Item 3**) to the hook and pile fastener. The end of the rain gutter will extend 10 to 12 inches out from the tent.
5. Pull the flaps of the roof cap (**Figure 14, Item 2**) down to seal the small opening where the rain gutters extend from the inside of the tent.
6. Ensure sure one end of the rain gutter (**Figure 14, Item 1**) is raised slightly higher than the other so rainwater will drain properly.
7. Install the 7-inch spacers (**Figure 14, Item 4**) between all adjacent tent legs.

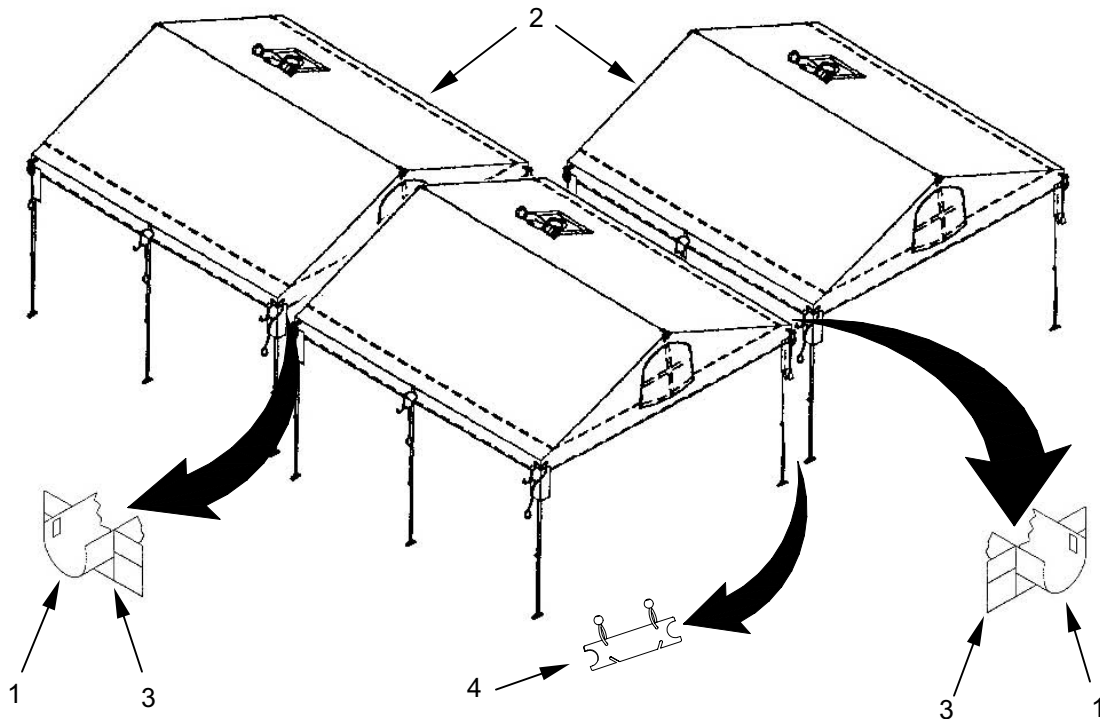

Figure 14. Complexing the Tents.

END OF TASK

Fabric Wall Assemblies Installation

NOTE

For ease of assembly, liner assemblies may be attached to wall assemblies before these are attached to the roof cap.

All tent fabric wall assemblies are interchangeable and will attach to any of the four sides of the roof cap. Decide which walls to use as follows:

1. Use the entrance way wall assembly (**Figure 15, Item 1**) on the side of the tent which is to be a personnel entry and exit.
2. Use the plain wall assembly or window wall assemblies (**Figure 15, Item 2**) on any side that is not an entrance way. Window wall assemblies should be placed on the side farthest from the stove pipe opening (**Figure 15, Item 3**).
3. Do not use a wall assembly on any side that will be complexed to another MCPS. Leave that wall in the transport bag. The rain gutter assembly is used to join the MCPS together.

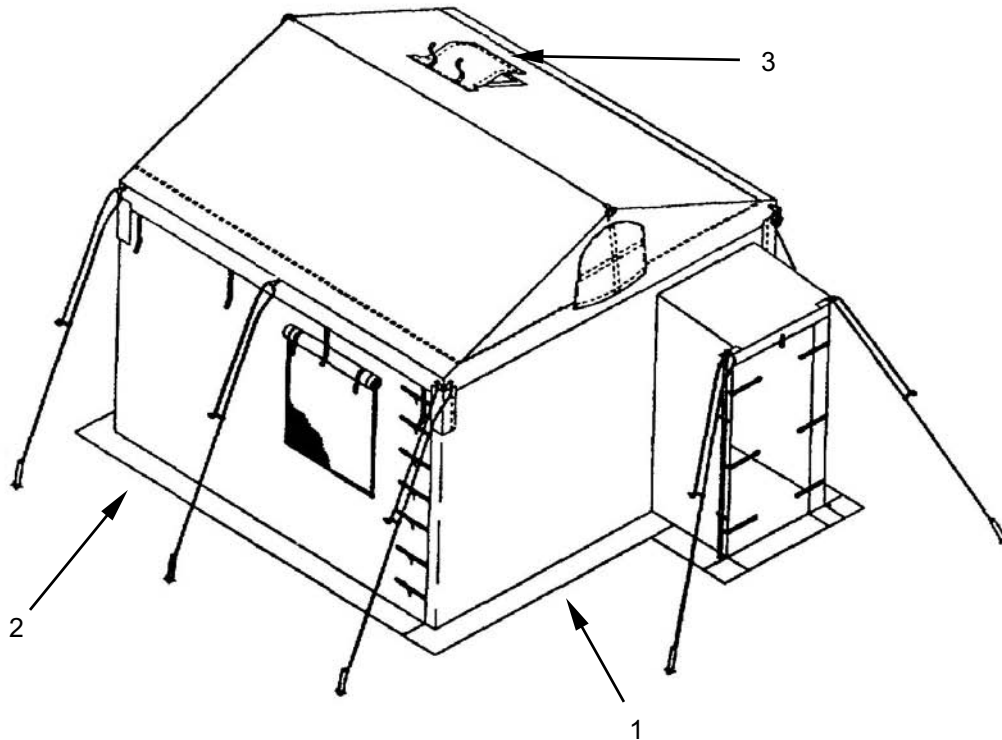

Figure 15. Fabric Wall Assemblies Installation (Type I Shown).

END OF TASK

Wall Assembly Setup

1. Unfold the desired wall assembly (**Figure 16, Item 1**), stretch it out, and position it so that the pile fastener strip (**Figure 16, Item 2**) faces the hook fastener strip (**Figure 16, Item 3**) on the roof cap (**Figure 16, Item 4**) and the quick release fasteners (**Figure 16, Item 5**) are on the inside.
2. The wall assembly (**Figure 16, Item 1**) attaches to the inside of the roof cap (**Figure 16, Item 4**) using quick release fasteners (**Figure 16, Item 5**) first and then the hook (**Figure 16, Item 3**) and pile (**Figure 16, Item 2**) fastener. Standing inside the tent, line the wall assembly up and fasten it to the roof cap with the quick release fasteners. The order in which you fasten the quick release fasteners doesn't matter, as long as they are lined up. Make sure the leg assemblies (**Figure 16, Item 6**) stay inside the tent. Take care to keep the hook and pile fasteners apart until quick release fasteners are fastened.
3. From inside the MCPS, starting in the center of the wall assembly (**Figure 16, Item 1**), line up the pile (**Figure 16, Item 2**) fastener strip on the wall assembly with the hook fastener (**Figure 16, Item 3**) on the roof cap assembly (**Figure 16, Item 4**) and press them together. Work from the center toward each end in order to prevent wrinkles in the hook and pile fastener strips.

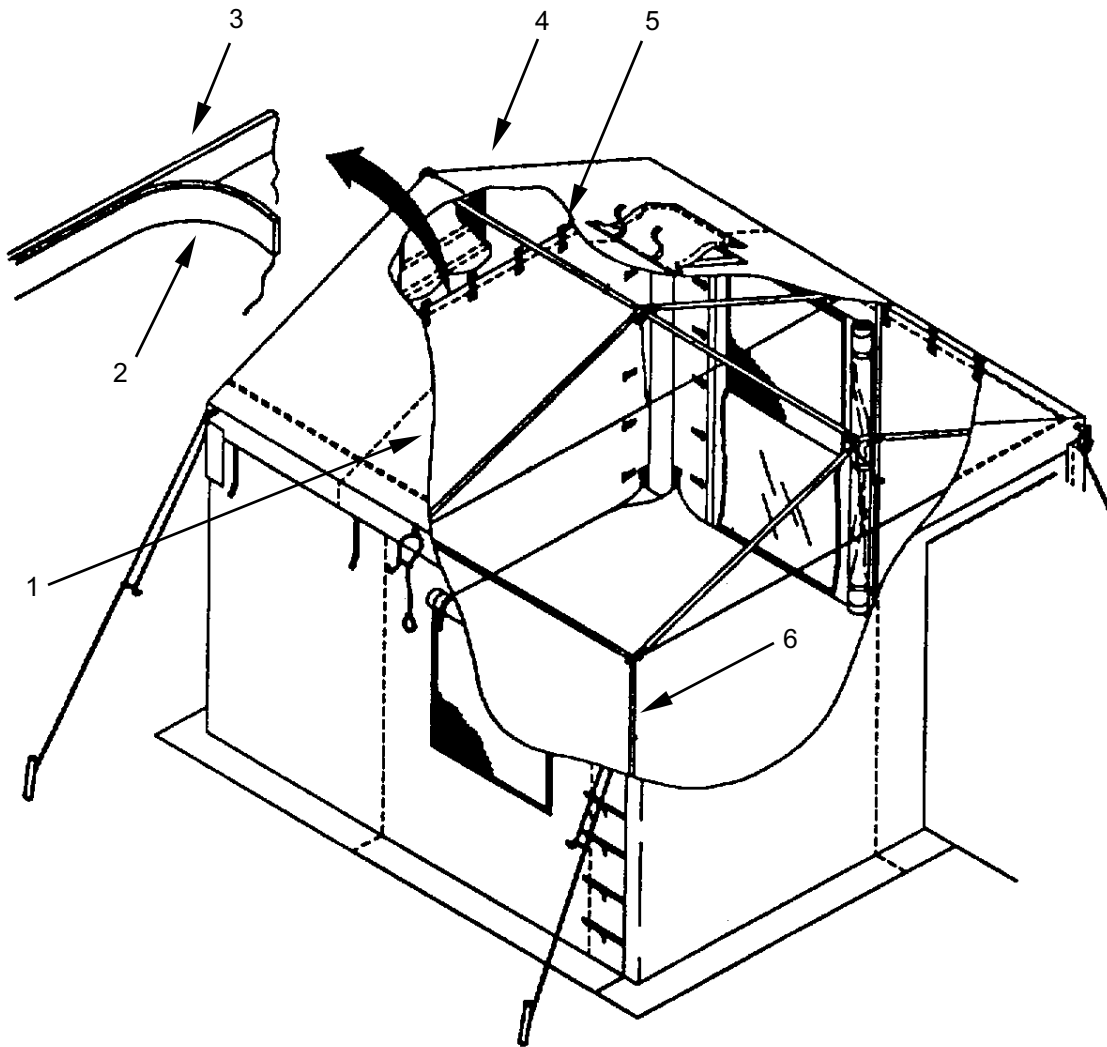

Figure 16. Wall Assembly Setup (Type I Shown).

END OF TASK

Connecting Wall Sections

1. Overlap the tent fabric at the corners of each wall (**Figure 17, Item 1**) by lining up the corresponding side strips of hook and pile fastener (**Figure 17, Item 2**) and pressing together.

NOTE

Strap assemblies always line up with the corresponding strap assembly on the left.

2. Fasten the row of quick disconnect fasteners (**Figure 17, Item 3**) on the inside corners of each wall. Draw the buckle straps (**Figure 17, Item 4**) tight.
3. Tighten the Corner Roof Cap guy lines (**Figure 17, Item 5**).
4. Fasten the quick disconnect fasteners on the outside of the wall corners and draw the buckle straps (**Figure 17, Item 6**) tight.
5. Each corner of the roof cap has flaps (**Figure 17, Item 7**) that must overlap the corresponding wall juncture. Pull the outside roof cap corner flaps down and press the hook and pile fasteners (**Figure 17, Item 8**). Make sure the strips are pressed tight, so that rainwater will stay out and interior light cannot escape.

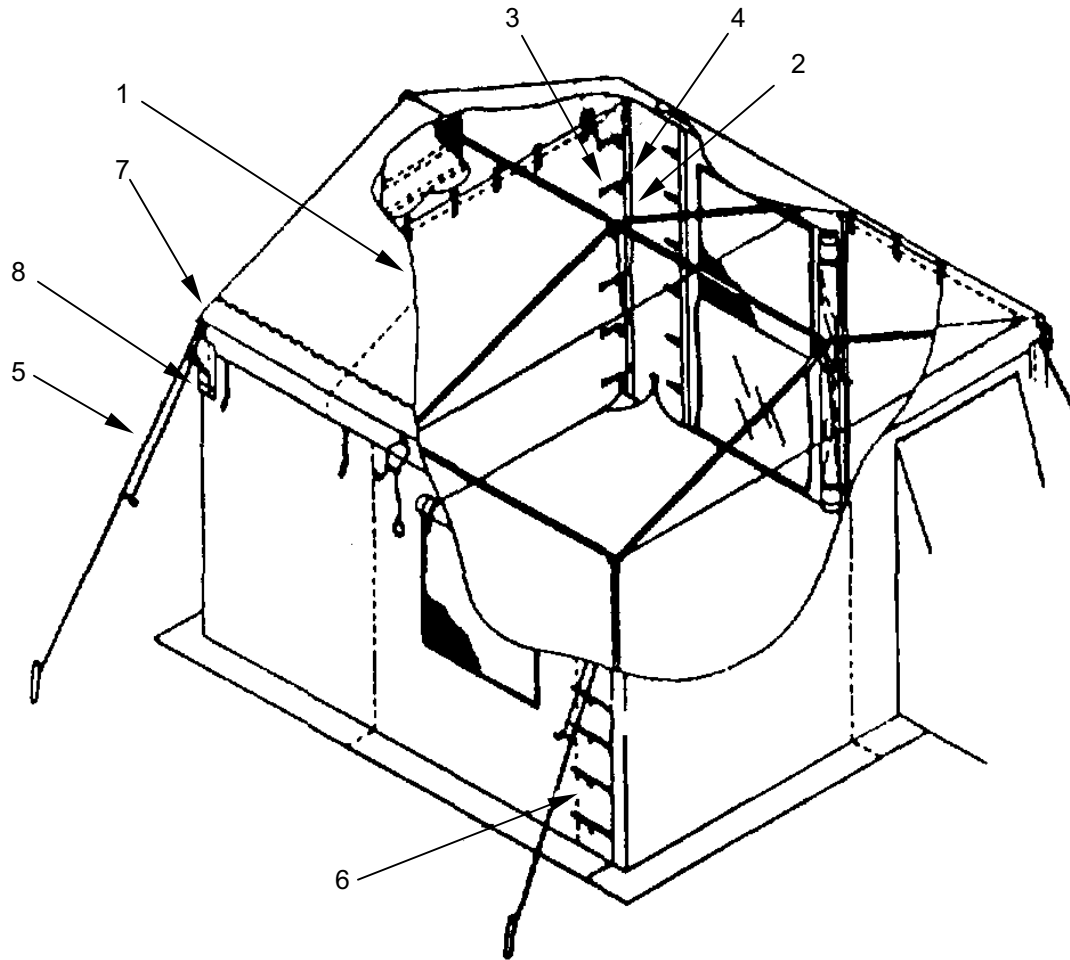

Figure 17. Connecting Wall Sections (Type I Shown).

END OF TASK

Entrance Way Set-Up

1. Locate the two telescopic poles (**Figure 18, Item 1**) which pull out and support the corners (**Figure 18, Item 2**) of the entrance way.
2. Place the bottom pointed end (**Figure 18, Item 3**) of each pole downward through the pole holders (**Figure 18, Item 4**) and grommets (**Figure 18, Item 5**) on the outside corner of each side of the entrance way.
3. Extend the height of each pole (**Figure 18, Item 1**) by pulling the upper portion out. The top and bottom are placed through the grommets (**Figure 18, Item 5**) sewn to the corners of the entrance way. The locking device (**Figure 18, Item 6**) secures the pole.
4. Pull out the tent lines (**Figure 18, Item 7**) 120 degrees diagonally and stake them into the ground at a 15 degree angle.

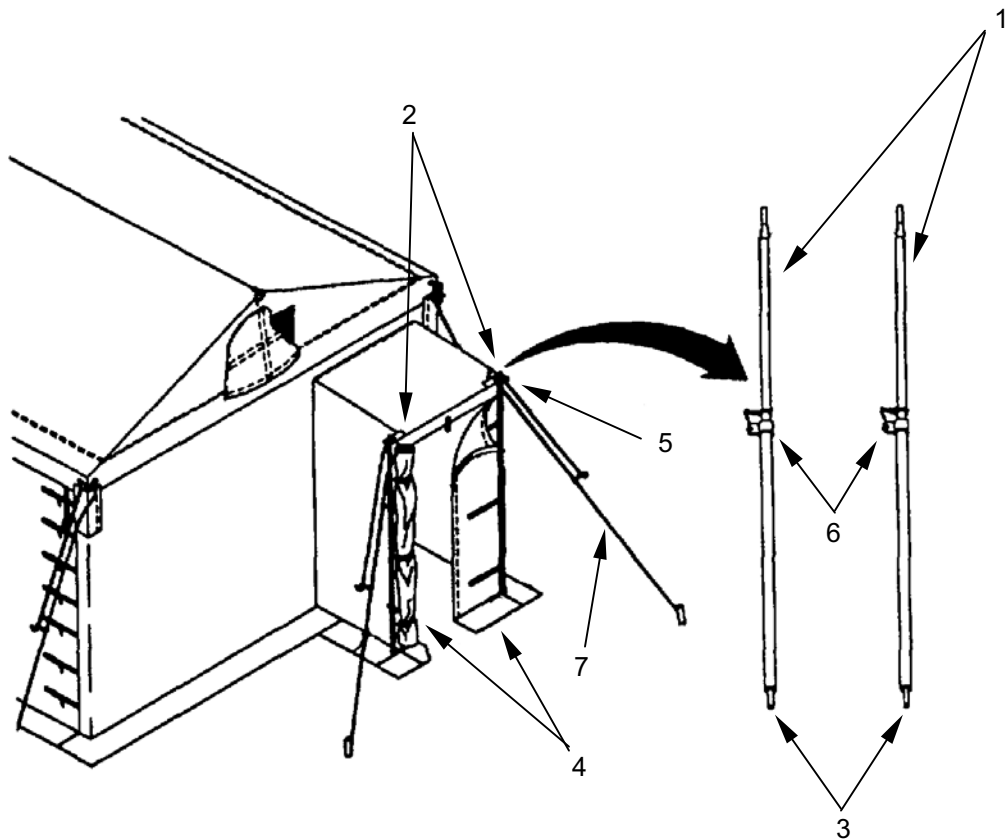

Figure 18. Entrance Way Set-Up.

END OF TASK

Wall Liner Installation

WARNING



Install the correct liner to the correct wall. Mismatched liners may block exits, result in a loss of function for the MCPS system, and restrict ventilation and climate control. Failure to observe correct installation may result in serious injury or death to personnel.

NOTE

The liners are designed to serve as insulation, as an outside wall during daylight hours and/or in hot weather (they breathe), and as partial dividers or privacy walls between adjoining complexed tents.

1. Use the hook and pile fasteners to hang each liner (**Figure 19, Item 1**) from the roof cap liner over the appropriate wall. Make sure the buckles (**Figure 19, Item 2**) face the tent interior.
2. Attach wall liners (**Figure 19, Item 1**) between legs (**Figure 19, Item 3**) of the frame and wall (**Figure 19, Item 4**) and along the top in the same way the walls were attached to the roof. The liners have hook and pile fasteners that will attach over the top of the walls and buckles that will match and attach to the top half of the buckles just unfastened. Make sure that the center legs are covered by the liner, and that the liner goes behind the corner legs. If tents are complexed, the liner should cover all legs except for those on the complex corners.
3. Fasten the corners (**Figure 19, Item 5**).
4. Buckle the floor (**Figure 19, Item 6**) to the liner (**Figure 19, Item 1**) (3 buckles per side).
5. The entrance way wall liner door (**Figure 19, Item 7**) should be opened if entry/exit is desired. Unfasten the quick disconnect fasteners and hook and pile fastener and roll the door section from one side to the other. Buckle assemblies with quick disconnect fasteners are provided to secure the liner open.

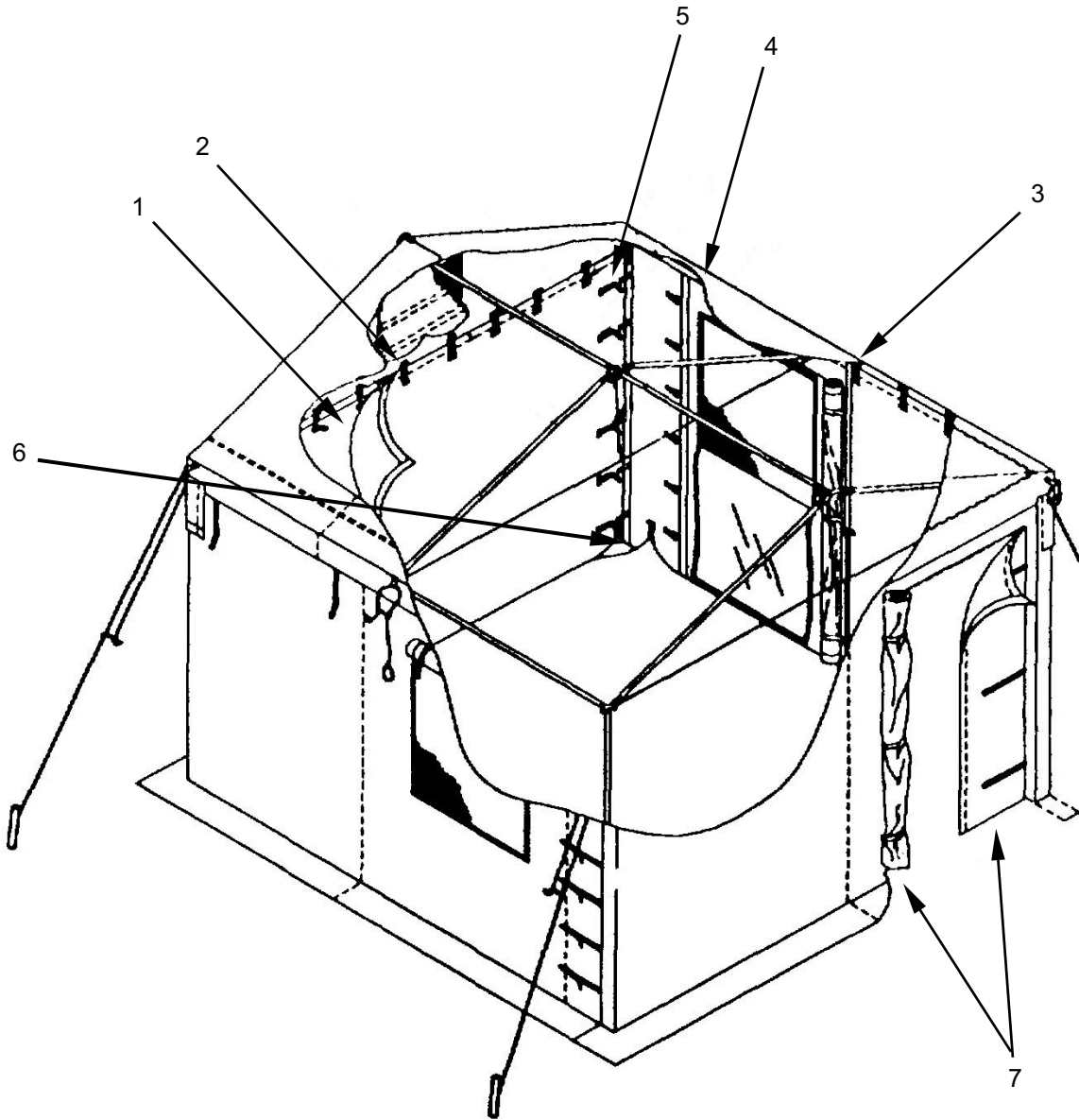

Figure 19. Wall Liner Installation (Type I Shown).

END OF TASK

Equipment Straps

Equipment straps (**Figure 20, Item 1**) are provided to hang items from the frame. To attach a strap, position the fabric over the top of the frame and push the hook through the loop of fabric. Then hang desired items from hook.

END OF TASK

Map Board

1. Position the mapboard sections (**Figure 20, Item 2**) side-by-side.
2. Line up the complexer tabs (**Figure 20, Item 3**) on one section with the slots in the next section.
3. Push the sections together. The tab (**Figure 20, Item 3**) at the center edge of one section will latch over the button on the center edge of the next section and fasten the mapboards (**Figure 20, Item 2**) together.
4. Suspend the mapboards (**Figure 20, Item 2**) from the frame using the equipment straps (**Figure 20, Item 1**).
5. Use any erasable grease pencils or markers on the rigid and flexible overlays.

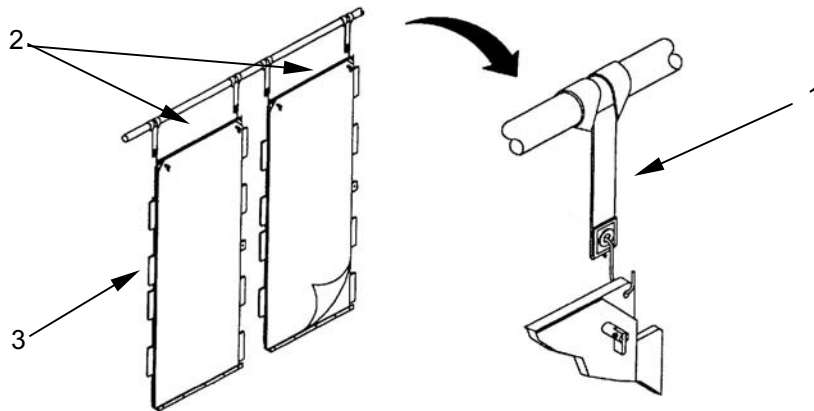

Figure 20. Equipment Straps and Mapboard.

END OF TASK

Folding Table

To release the legs (**Figure 21, Item 1**), unfold them to an upright position. The legs will automatically lock into place.

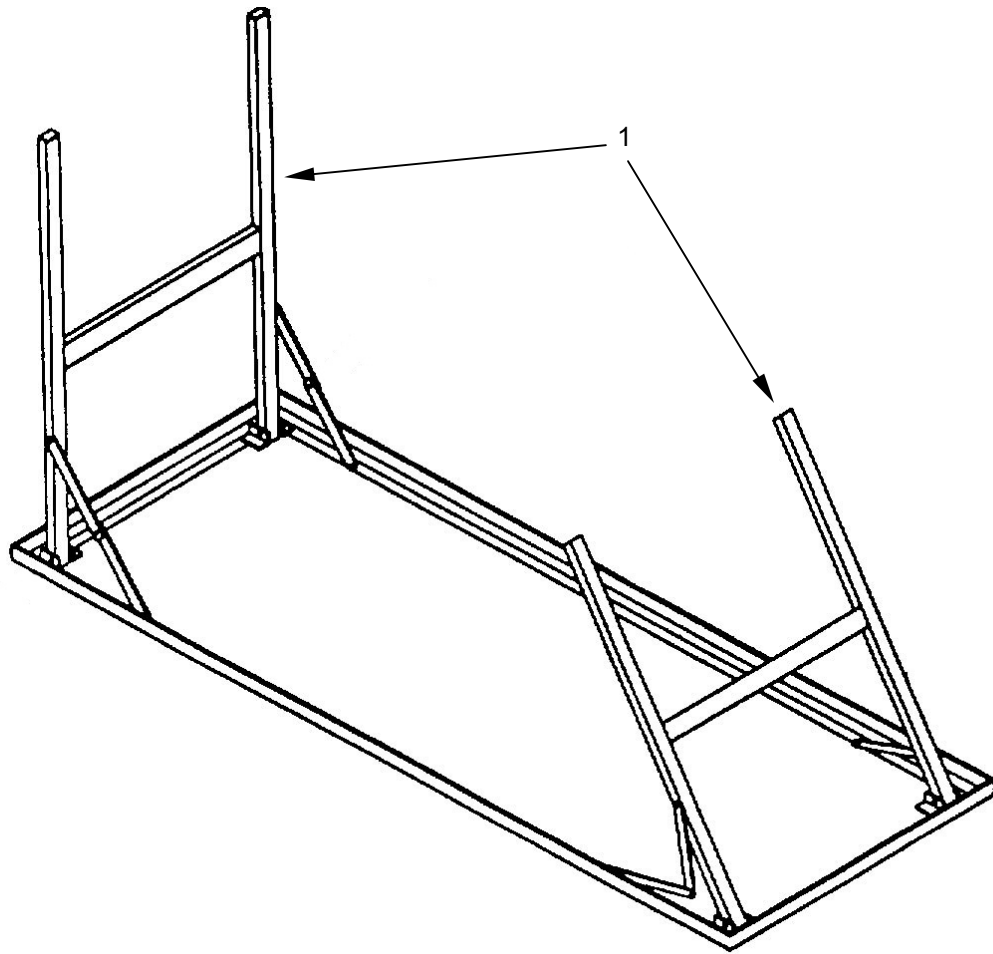

Figure 21. Folding Table.

END OF TASK

OPERATING PROCEDURES

WARNING



Doors and windows should remain closed during hours of darkness to maintain blackout. Failure to observe blackout conditions may result in serious injury or death to personnel.

Window Openings

The window openings (**Figure 22, Item 1**) have a window flap, screen and clear plastic window. The outside window flap may be rolled under and up toward the top of the tent and fastened using the fabric ties attached to the tent. Always roll the window flap under to prevent the collection of water, ice and snow on the flap. The screen portion is not removable. The clear window is held in place by hook and pile fastener strips and when open, hangs down on the inside of the MCPS.

Entrance Way Doors

The inner and outer doors (**Figure 22, Item 2**) may be opened during daylight hours to provide increase ventilation and/or easier entry and exit. They may be simply clipped back out of the way to form a triangle covering half of the entry, or they may be rolled straight across completely out of the way and tied back with the quick disconnect fasteners.

Stove Pipe Flap

If an internal space heater is to be used, the stove pipe flaps (**Figure 22, Item 3**) on both the roof cap and the roof cap liner must be opened and tied back when those components are installed. If the need for an internal space heater develops after the tent has been erected, a self supporting step aid such as a step ladder must be used to open the flaps, or the tent legs must be lowered to allow access to the flaps.

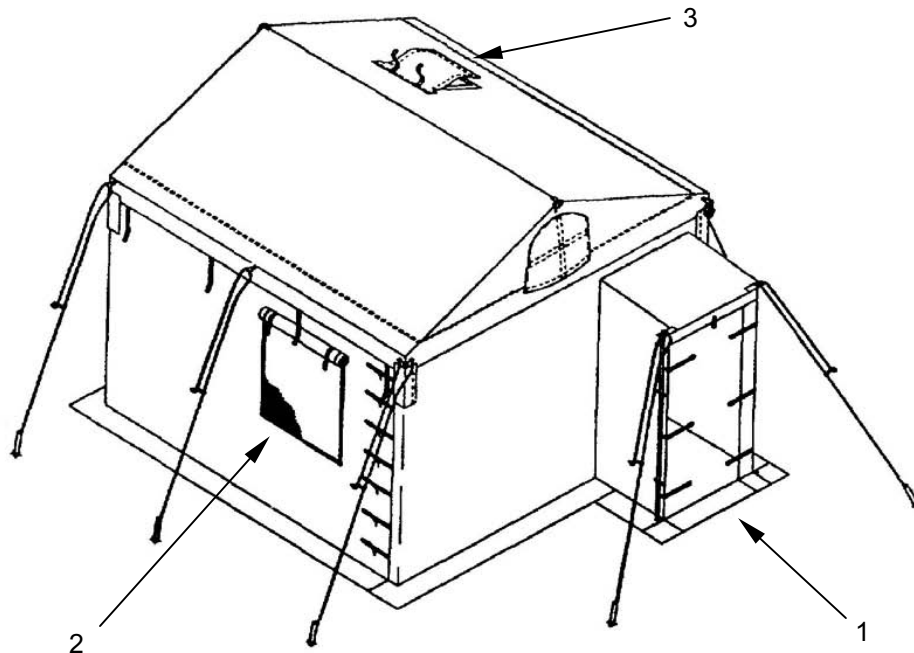

Figure 22. Operation of Windows and Doors (Type I Shown).

DECALS AND INSTRUCTION PLATES

A label containing abbreviated MCPS set up instructions is sewn to the inside of the frame transport bag.

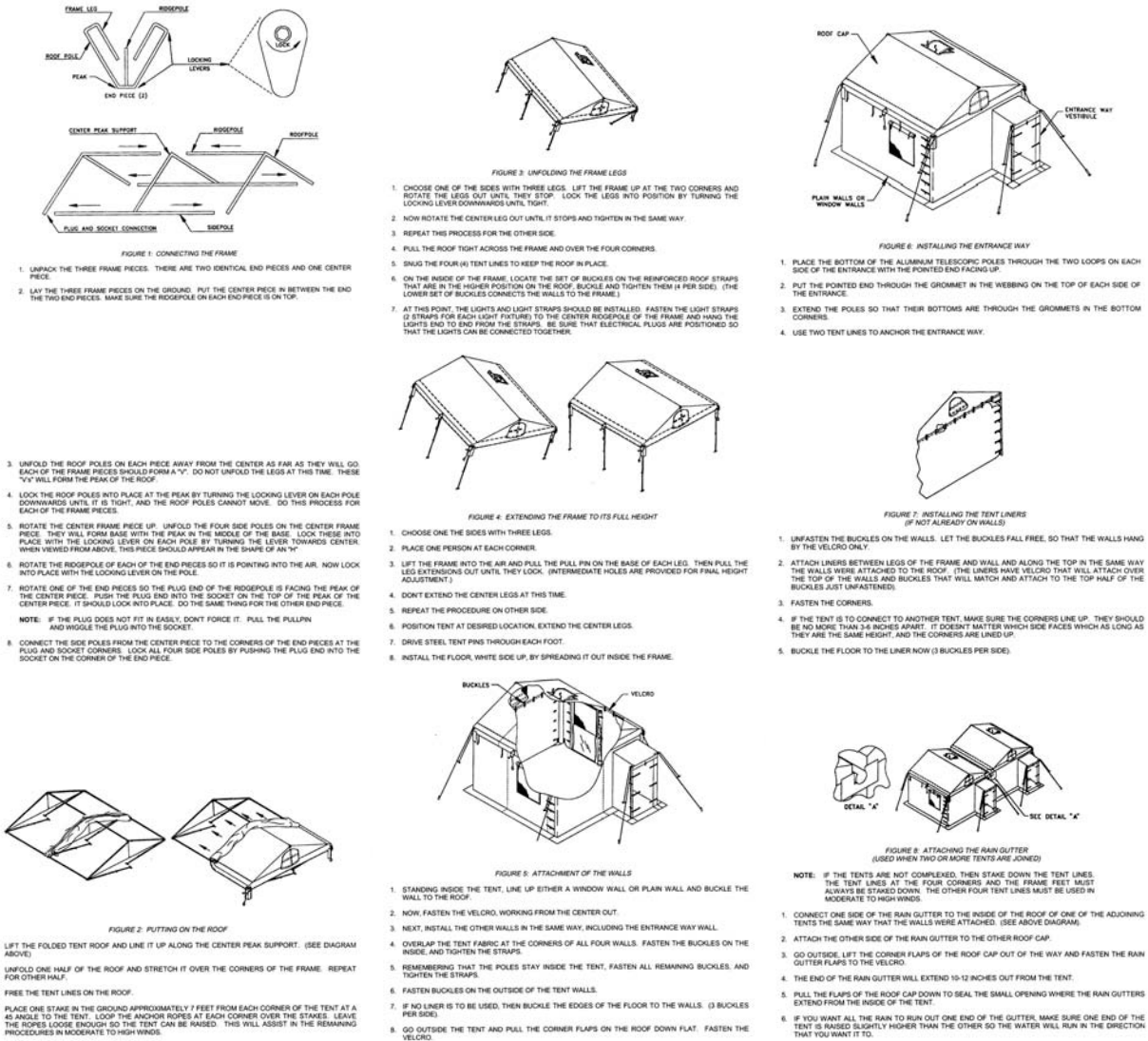

Figure 23. MCPS Setup Label on Frame Transport Bag.

Identification labels are found on the inside of each tent fabric assembly, and transport bag.

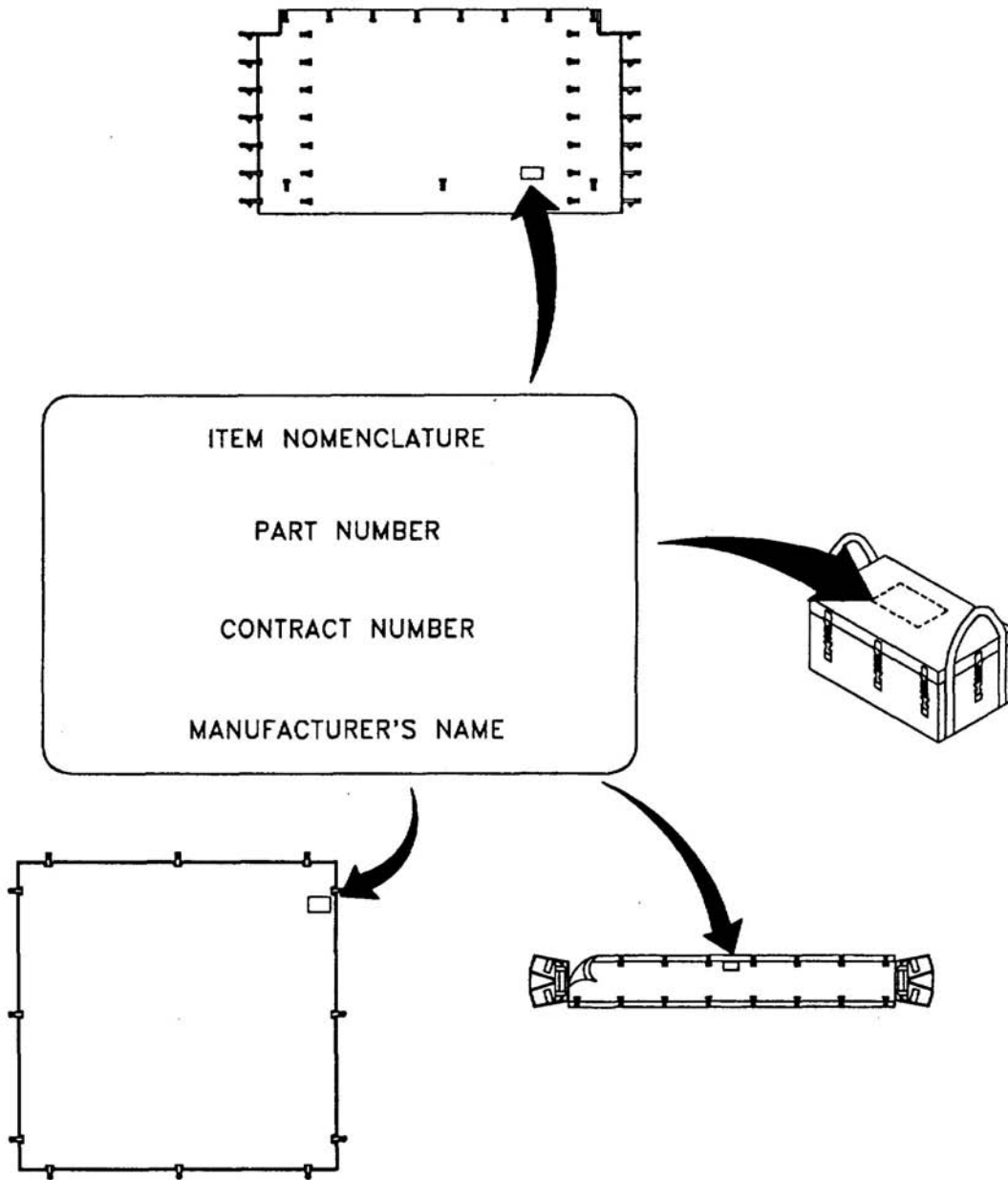

Figure 24. Identification Labels.

PREPARATION FOR MOVEMENT**NOTE**

As time and circumstances allow, perform operator PMCS "After" services. Clean and dry tent fabric sections and equipment before packing.

Table

1. Unlock the hinges (**Figure 25, Item 1**) by pressing the center in towards the table top.
2. Fold the legs (**Figure 25, Item 2**) of the table in towards the center and remove from tent.

END OF TASK**Mapboards (Type I Only)**

1. Lift the mapboards (**Figure 25, Item 3**) off the equipment straps (**Figure 25, Item 4**) and pull the sections apart by lifting the tab over the button at the center edge of each mapboard section and sliding the mapboards apart.
2. Remove mapboards (**Figure 25, Item 3**) from tent.
3. Remove straps (**Figure 25, Item 4**) and store in tent pin container.

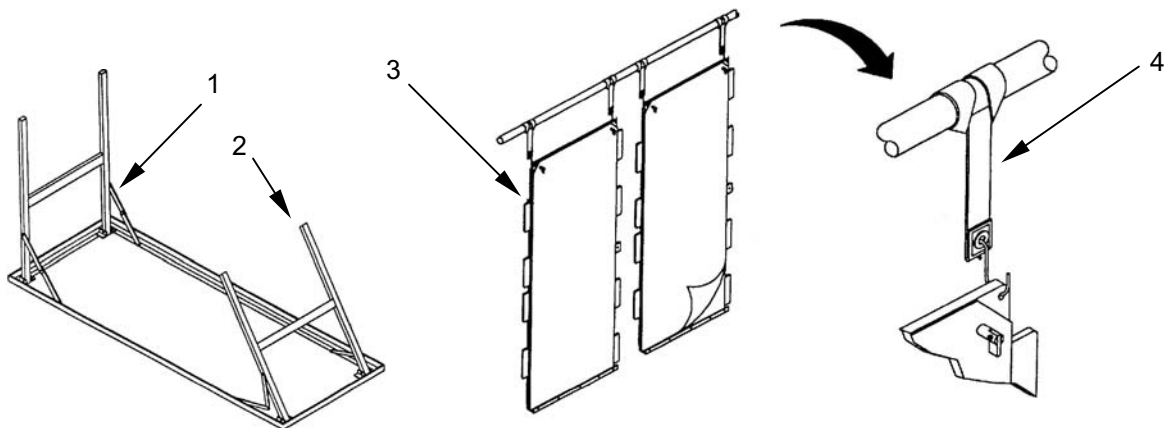

Figure 25. Prepare Tables and Mapboards for Movement.

END OF TASK

Lights

Unplug the power source cord from the lights (**Figure 26, Item 1**). Do not remove the lights until the frame assembly has been lowered.

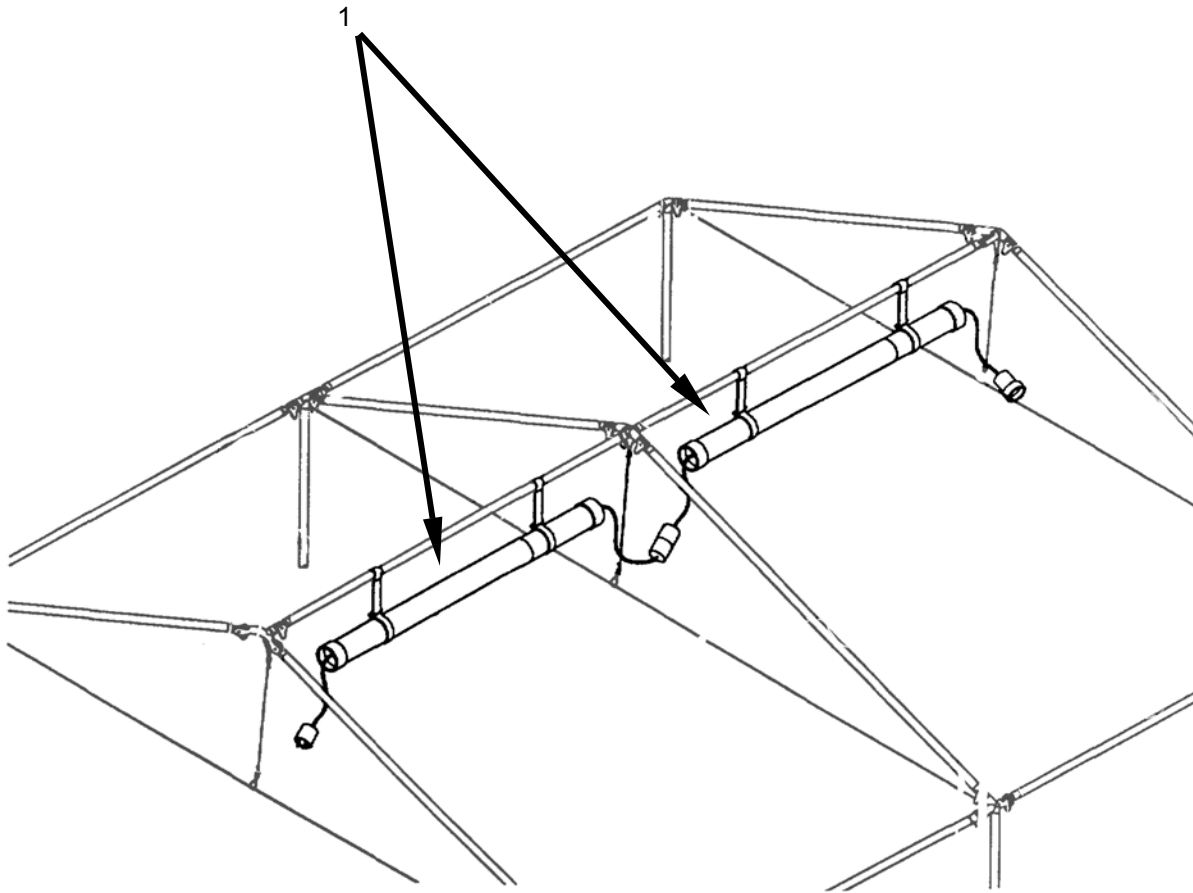

Figure 26. Disconnect Power from the Lights.

END OF TASK

Fabric Sections

NOTE

The MCPS roof cap and roof cap liner can only be removed after the frame has been lowered.

NOTE

If bootwalls are employed, remove IAW TM 10-5410-230-13.

1. Close all windows (**Figure 27, Item 1**) and loosen all tent lines (**Figure 27, Item 2**). Do not remove lines.
2. Release all quick disconnect (**Figure 27, Item 3**) and hook and pile fasteners (**Figure 27, Item 4**) at inside and outside corners.
3. If fitted, remove the rain gutter liner and then the rain gutter (**Figure 27, Item 5**) from the inside of the MCPS by unfastening all quick disconnect (**Figure 27, Item 3**) and hook and pile fasteners (**Figure 27, Item 4**). Fold with identification label visible and place in fabric transport bag.
4. Remove the telescopic poles (**Figure 27, Item 6**) at entrance way by pushing up on the locking device (**Figure 27, Item 7**). Collapse poles and place them in the frame transport bag.
5. Remove steel pins (**Figure 27, Item 8**) from entrance way wall (**Figure 27, Item 9**) and place in tent pin container.
6. Close and secure left (**Figure 27, Item 10**) and right (**Figure 27, Item 11**) blackout doors and outer blackout doors (**Figure 27, Item 12**) on end wall assembly (**Figure 27, Item 13**).
7. Remove all liner assemblies (**Figure 27, Item 14**). Release all quick disconnect (**Figure 27, Item 3**) and hook and pile fasteners (**Figure 27, Item 4**). Fold each liner with identification label visible and place in fabric transport bag.
8. Release quick disconnect fasteners (**Figure 27, Item 15**) connecting the floor (**Figure 27, Item 16**) to the walls. Remove and fold floor with identification label visible and place in fabric transport bag.
9. Remove walls by releasing all quick disconnect (**Figure 27, Item 3**) and hook and pile fasteners (**Figure 27, Item 4**). Fold the wall assemblies with identification labels visible and place in fabric transport bag.
10. Release the remaining quick disconnect fasteners (**Figure 27, Item 17**) holding the roof cap (**Figure 27, Item 18**) to the frame assembly (**Figure 27, Item 19**).

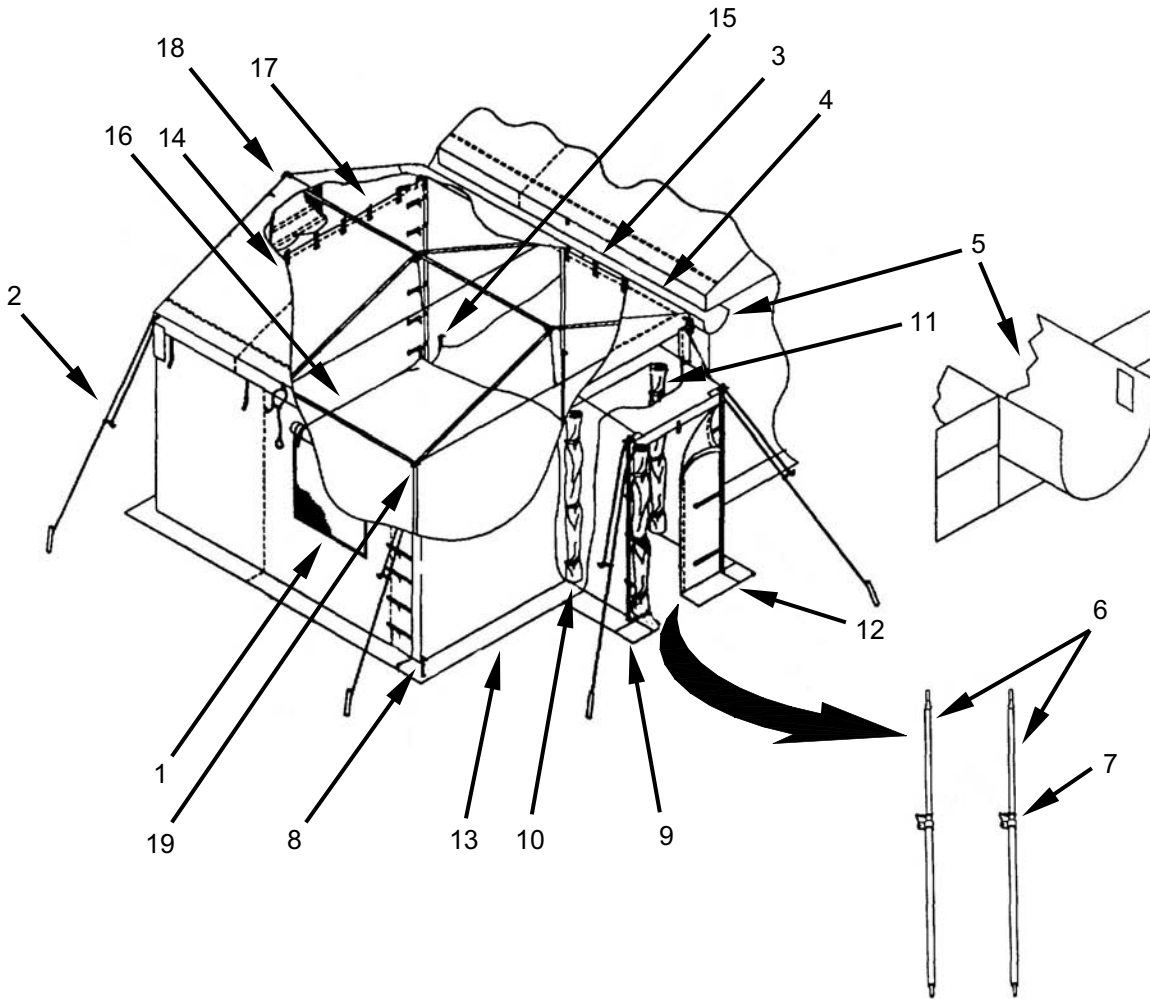

Figure 27. Prepare MCPS Fabric Sections for Movement (Type I Shown).

END OF TASK

Roof Cap Fabric

WARNING



When handling tent frame, do not grasp the frame near the frame joints. Failure to do so can result in personnel injury to hands and fingers. Failure to follow tie down and staking instructions may result in possible injury to personnel and damage to equipment.

1. Remove steel tent pins (**Figure 28, Item 1**) from feet (**Figure 28, Item 2**) of the frame assemblies and store in the tent pin container.
2. Collapse the legs (**Figure 28, Item 3**) of the center wall frame assembly (**Figure 28, Item 4**) on each side of the MCPS by pulling the pull pins (**Figure 28, Item 5**), rotating the feet (**Figure 28, Item 2**) 90 degrees, and pushing the lower leg assembly (**Figure 28, Item 6**) up. Be sure the lower leg assemblies lock once they are collapsed.
3. Collapse one side of the MCPS at a time by pulling the pull pins (**Figure 28, Item 5**) on the end wall assemblies (**Figure 28, Item 7**), rotating the feet (**Figure 28, Item 2**) 90 degrees, and lowering the frame assembly. Be sure the leg assemblies lock once they are collapsed.
4. Unlock the handles (**Figure 28, Item 8**) on the two center legs (**Figure 28, Item 3**) by pushing them towards the center of the MCPS.
5. Choose one side with three leg assemblies (**Figure 28, Item 3**). Stand outside at the two corners of that side. Unlock the handles (**Figure 28, Item 8**) on these two corners. Lift the side of the frame assembly up and swing the leg assemblies in towards the center. Place this side of the frame assembly on the ground. Repeat procedure on other side.
6. Remove all tent lines (**Figure 28, Item 9**) from wooden tent pins. Remove tent pins and place in tent pin container.
7. With one person on each corner, lift the roof cap assembly (**Figure 28, Item 10**) over the corners and the end peak fitting (**Figure 28, Item 11**).
8. Fold roof cap assembly (**Figure 28, Item 10**) in half from one end towards the center wall frame assembly (**Figure 28, Item 4**). Repeat this step from both ends until roof cap assembly is about 2 feet wide and laying over the peak center joint (**Figure 28, Item 12**) and rafter assemblies (**Figure 28, Item 13**).
9. Lift the folded roof cap (**Figure 28, Item 10**) off the center wall frame assembly (**Figure 28, Item 4**), fold in fourths, and place in fabric transport bag.
10. Release the hook and pile fasteners retaining the roof cap liner to the frame (**Figure 28, Item 14**).
11. Release the hook and pile faster securing the roof cap liner slit (**Figure 28, Item 15**), and remove the roof cap liner (**Figure 28, Item 14**). Fold the roof cap liner with the identification label showing.
12. Remove the lights (**Figure 28, Item 16**) and straps (**Figure 28, Item 17**).

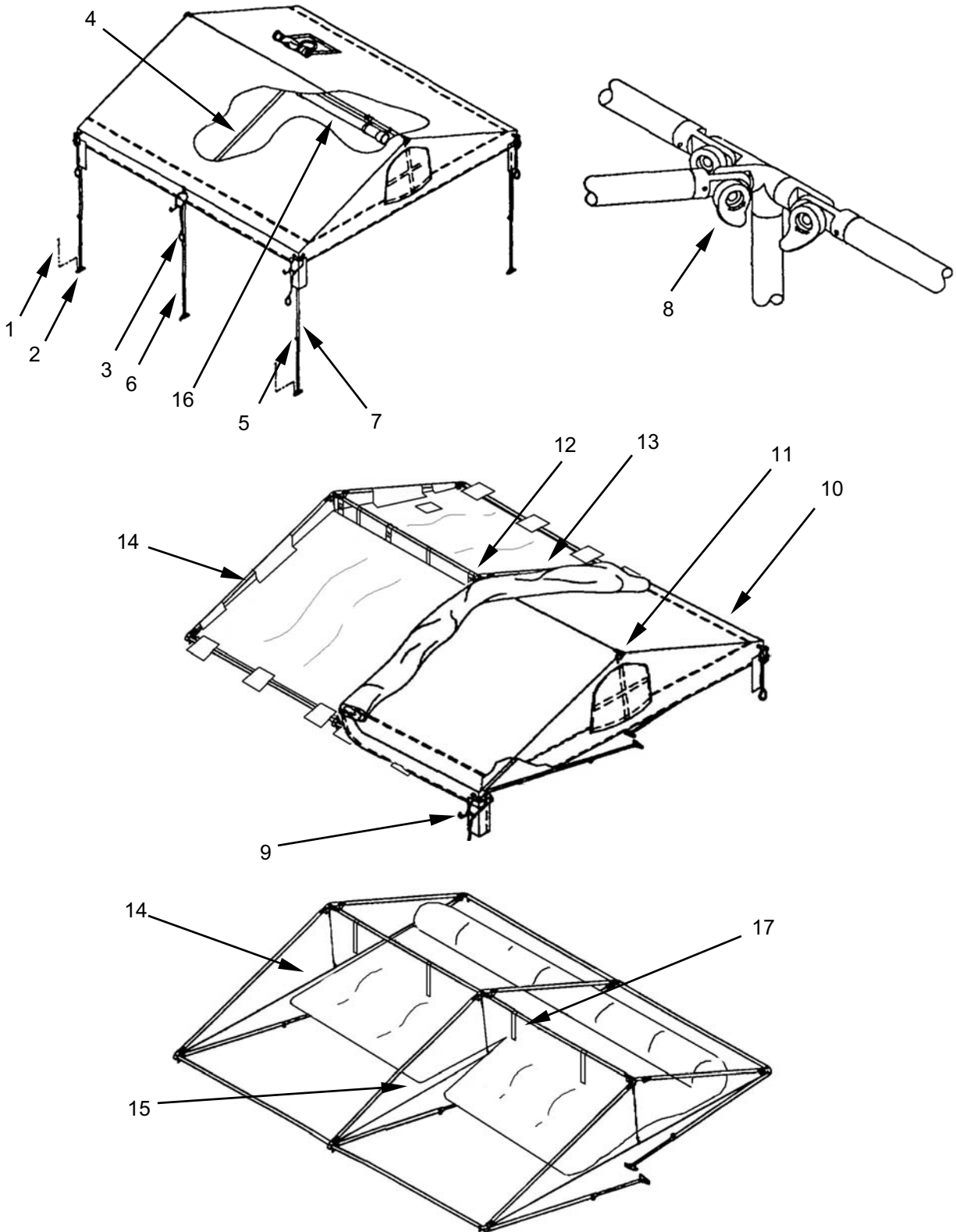

Figure 28. Roof Cap Fabric.

END OF TASK

Frame Sections

WARNING



When handling tent frame, do not grasp the frame near the frame joints. Failure to do so can result in personnel injury to hands and fingers. Failure to follow tie down and staking instructions may result in possible injury to personnel and damage to equipment.

CAUTION

Do not stand or walk on tent frame assemblies. They can be damaged by misuse. When handling tent frame do not twist or force the frame. Unfold frame sections on the ground. Do not pick up the frame to unfold it, as this will cause binding of the fitting assemblies and damage to the frame can result.

NOTE

Disassembly of the tent frame requires at least two persons.

1. Standing at one of the end wall frame assemblies (**Figure 29, Item 1**), disconnect the left hand (**Figure 29, Item 2**) and right hand (**Figure 29, Item 3**) purlins from the center wall frame assembly (**Figure 29, Item 4**) by pulling the pin (**Figure 29, Item 5**) at the connector and socket connection.
2. Disconnect the left hand purlin (**Figure 29, Item 2**) on the end wall frame assembly (**Figure 29, Item 1**) by pulling the pin (**Figure 29, Item 5**) at the plug and socket connection on the peak center joint (**Figure 29, Item 6**).
3. Loosen the three handles (**Figure 29, Item 7**) at the end peak fitting (**Figure 29, Item 8**). Fold the left hand purlin (**Figure 29, Item 2**), the leg assemblies (**Figure 29, Item 9**), and the rafter assemblies (**Figure 29, Item 10**) in towards the center. Place in frame transport bag.
4. Repeat steps 1 through 3 for the other end wall frame assembly and place in frame transport bag.
5. On the center wall frame assembly (**Figure 29, Item 4**), loosen the handles (**Figure 29, Item 7**) on the left hand (**Figure 29, Item 11**) and right hand (**Figure 29, Item 12**) purlins and fold the purlins in towards the center.
6. Lay the center frame assembly (**Figure 29, Item 4**) on its side. Loosen the handles (**Figure 29, Item 7**) at the center peak joint (**Figure 29, Item 6**) by turning them upward. Fold the left hand (**Figure 29, Item 11**) and right hand (**Figure 29, Item 12**) purlins, the leg assemblies (**Figure 29, Item 13**), and the rafter assemblies (**Figure 29, Item 14**) in towards the center.
7. Place the center wall frame assembly (**Figure 29, Item 4**) into the frame transport bag.

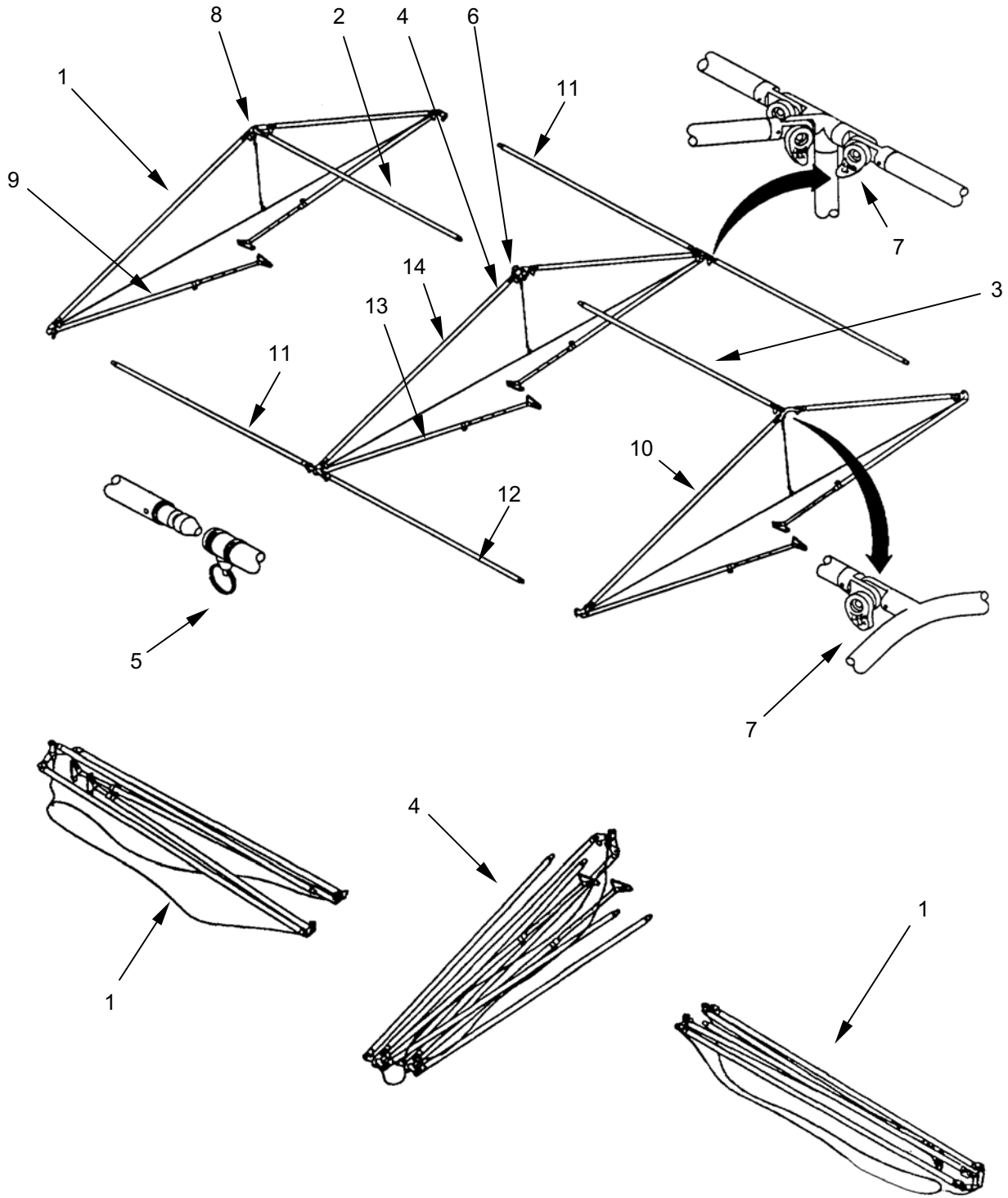

Figure 29. Preparing Frame Sections for Movement.

END OF TASK

END OF WORK PACKAGE

**OPERATOR, UNIT, AND DIRECT SUPPORT MAINTENANCE
MODULAR COMMAND POST SYSTEM (MCPS), SMALL
OPERATION UNDER UNUSUAL CONDITIONS**

UNUSUAL ENVIRONMENT/WEATHER

Refer to this work package for steps and precautions to take in the even of adverse or unusual environmental conditions.

Operation in Heavy Rain or Flooding

- Ensure that all tent lines and frame feet are staked.
- Frequently check all tent pins and lines. Tent lines may shrink from dampness, so keep tent lines loose enough to prevent tent pins from being pulled out of the ground.
- Check all seams and joints for proper fit and potential leakage.
- Close and fasten all windows and doors.
- Dig a trench around the perimeter of the tent or tent complex.
- Disconnect power if leaks occur.

Operation in Extreme Moist Heat

- Ensure all entrances and openings are secure if an ECU is employed.
- If no ECU is available, allow for as much ventilation as operating conditions will permit. Wall fabric may be rolled up or removed if permissible by mission requirements. If tent walls are rolled up, ensure that the wall is rolled up inside the tent to prevent accumulation of moisture in tent fabric.
- Tent lines may shrink from dampness, so keep tent lines loose enough to prevent tent pins from being pulled out of the ground.
- Ensure that tent fabric has an opportunity to thoroughly air out and dry as soon as practical in order to prevent mildew.

Operation in Extreme Dry Heat

- Ensure all entrances and openings are secure if an ECU is employed.
- If no ECU is available, allow for as much ventilation as operating conditions will permit. Wall fabric may be rolled up or removed if permissible by mission requirements. If tent walls are rolled up, ensure that the wall is rolled up inside the tent to prevent accumulation of dust or dirt in tent fabric.

Operation in Extreme Cold

- If ground is frozen too hard to drive steel tent pins, chop small holes to set them in. Fill holes with slush or water and allow to freeze and anchor pins.
- Close and fasten all windows and doors. An external or internal heater must be employed.
- Ensure no ice or snow accumulates on tent roof or in gutters.

Operation in Salt Air or Sea Spray

- Frequently check all tent pins and lines. Tent lines may shrink from dampness, so keep tent lines loose enough to prevent tent pins from being pulled out of the ground.
- Check all seams and joints for proper fit and potential leakage.
- Close and fasten all windows and doors.
- Dig a trench around the perimeter of the tent or tent complex.
- Disconnect power if leaks occur.
- Ensure all components are rinsed with fresh water as soon as often as practical, and before preparing for movement.

Operation in Dust Storms or Sand Storms

- Check stakes and guy lines as often as possible, and apply extra guy lines and stakes if available. Ensure all entrances and openings are secure.
- Ensure all components are rinsed with fresh water as soon as often as practical, and before preparing for movement.

Operation in High Altitude

- There are no specific operational requirements or restrictions for operation in high altitudes.

Operation in Snow

- If putting up the MCPS in snow conditions, gently press the snow down to provide a firm surface on which to set up.
- If ground is frozen too hard to drive steel tent pins, chop small holes to set them in. Fill holes with slush or water and allow to freeze and anchor pins.
- Check stakes and guy lines as often as possible, and apply extra guy lines and stakes if available.
- Close and fasten all windows and doors.
- Ensure no ice or snow accumulates on tent roof or in gutters.
- Ensure all components are rinsed with fresh water as soon and as often as practical, and before preparing for movement.

Operation in Mud

- Check stakes and guy lines as often as possible, and apply extra guy lines and stakes if available.
- Close and fasten all windows and doors.
- Ensure all components are rinsed with fresh water as soon as often as practical, and before preparing for movement.

INTERIM NUCLEAR, BIOLOGICAL, AND CHEMICAL (NBC) DECONTAMINATION PROCEDURES

1. If chemical or biological contamination is expected, close all MCPS openings, such as windows, doors, and stove pipe openings.

NOTE

Perform unit level decontamination of the MCPS only under supervision of unit NBC personnel.

2. If MCPS is set up, decontaminate the fabric around the entrance way area of nuclear, chemical or biological contamination by applying Standard Tropical Bleach (STB) slurry or brushing with hot, soapy water.
3. Prepare slurry by mixing approximately equal parts of water with STB. Use a swab, or broom to scrub slurry into fabric.
4. Remove slurry promptly with brush and liberal quantities of water, preferably hot and soapy, then rinse with clear water.

NOTE

STB slurry may leave a harmless, white chalky residue.
This is not a cause for concern.

5. Decontaminate the remaining sections of the MCPS by natural methods. Expose the erected tent to the effects of weather and aeration for approximately 2 to 3 days.

CAUTION

Heavy concentrations of Decontaminating Solution 2 (DS2) are harmful to the MCPS fabric. A fine spray mist is recommended. Do not scrub with mop or broom.

NOTE

DS2 will cause some change in fabric color.

6. Aeration is not effective against V agents. If contaminated by V-agent entire MCPS must be decontaminated with DS2 slurry.

END OF TASK

END OF WORK PACKAGE

CHAPTER 3
TROUBLESHOOTING MASTER INDEX
FOR
MODULAR COMMAND POST SYSTEM (MCPS), SMALL

**OPERATOR MAINTENANCE
MODULAR COMMAND POST SYSTEM (MCPS), SMALL
TROUBLESHOOTING INDEX**

TROUBLESHOOTING INDEX

GENERAL

This chapter provides operator maintenance information and includes troubleshooting and general maintenance procedures. Refer to appropriate technical manuals for associated equipment maintenance instructions and item-specific troubleshooting instructions (Refer to Work Package 0044 for References). Troubleshooting instructions covered in this section are unique to the MCPS.

MALFUNCTION SYMPTOM INDEX

The malfunction symptom index lists common malfunctions that may occur during MCPS inspection and operation. Find the malfunction to be eliminated and go to the indicated troubleshooting paragraph that follows. The index cannot list all malfunctions that may occur, all tests or inspections needed to find the fault, nor all actions required to correct the fault. If the existing malfunction is not listed, or cannot be corrected through this troubleshooting index, notify unit maintenance.

Field Table not steady	0008-5
Frame assemblies will not fit together.....	0008-1
Tent lights do not light	0008-4
MCPS will not stay taut	0008-3
Tent leaking.....	0008-2

END OF WORK PACKAGE

CHAPTER 4
TROUBLESHOOTING PROCEDURES
FOR
MODULAR COMMAND POST SYSTEM (MCPS), SMALL

**OPERATOR MAINTENANCE
MODULAR COMMAND POST SYSTEM (MCPS), SMALL
TROUBLESHOOTING PROCEDURES**

INITIAL SETUP**Tools and Special Tools**

None Required

Personnel Required

One

Materials/Parts

None Required

References

WP 0005, WP 0012, WP 0013

Equipment Condition

MCPS set up and lighting installed

TROUBLESHOOTING PROCEDURE**SYMPTOM**Frame assemblies (**Figure 1, Item 1**) will not fit together.**MALFUNCTION**Missing or bent frame components.
Damaged fittings.**CORRECTIVE ACTION**

Replace any bent or missing frame components and continue setup as described in WP 0005.

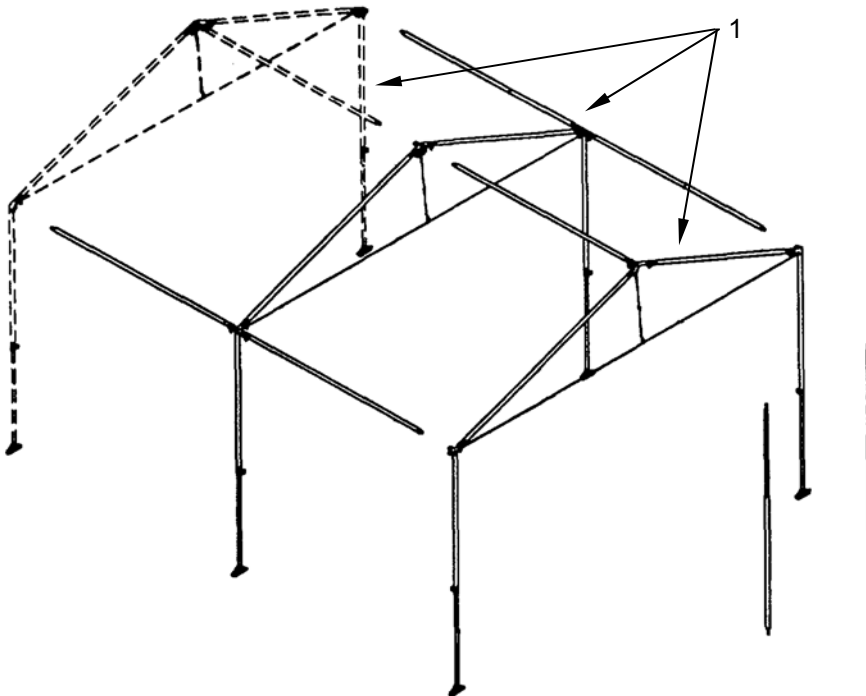

Figure 1. Frame Assembly Troubleshooting.

SYMPTOM

Tent leaking.

MALFUNCTION

Windows (**Figure 2, Item 1**) not sealed correctly.
Stove pipe opening (**Figure 2, Item 2**) not closed.
Hook and pile fasteners (**Figure 2, Item 3**) unsecured.

CORRECTIVE ACTION

Secure loose or open fittings properly

MALFUNCTION

Rips, tears, holes or separating seams in the roof cap (**Figure 2, Item 4**) or wall fabric assemblies (**Figure 2, Item 5**)

CORRECTIVE ACTION

Repair any rips, tears, or holes not exceeding 6 inches in length using the Tentage Repair Kit. Replace fabric assemblies with damage exceeding 6 inches in length.

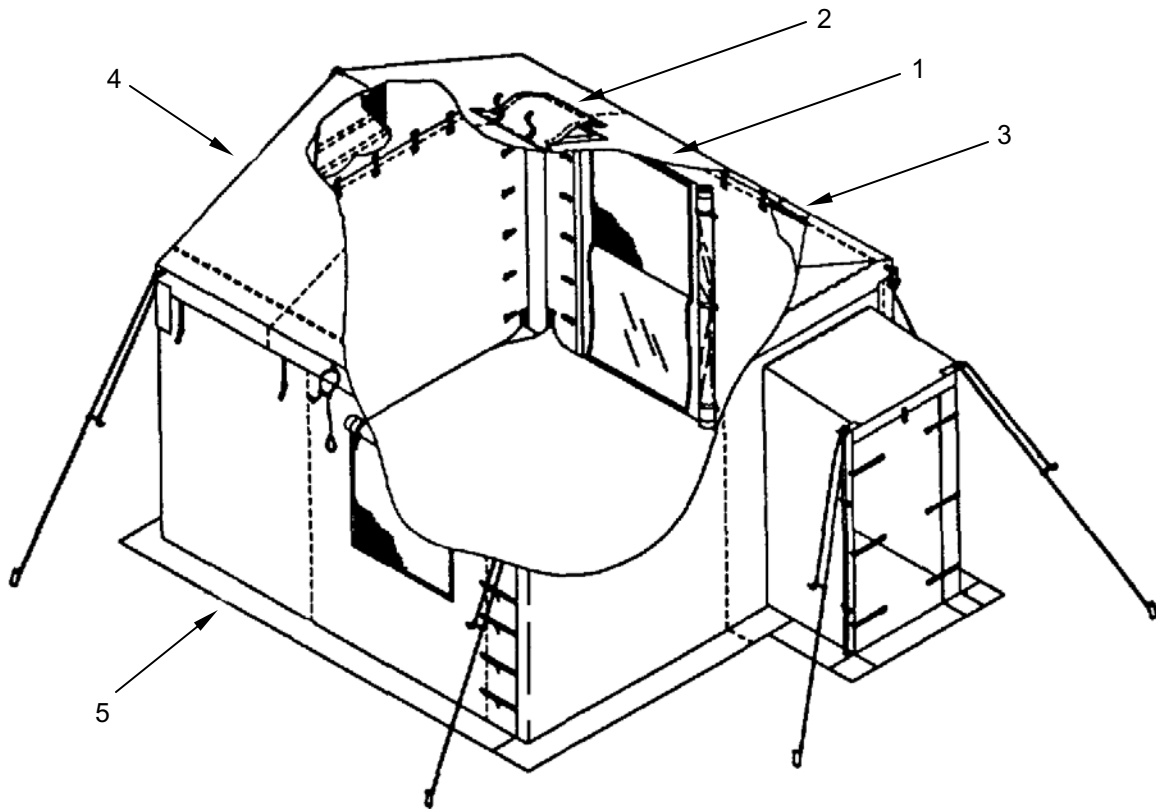

Figure 2. Tent Leaking Troubleshooting (Type I Shown).

SYMPTOM

MCPS will not stay taut.

MALFUNCTION

Tent lines (Figure 3, Item 1), tent pins (Figure 3, Item 2), and tent line slips (Figure 3, Item 3) improperly fitted or damaged.

CORRECTIVE ACTION

Replace damaged or missing tent lines, tent pins, or tent line slips.
Ensure tent is set up and staked IAW procedures given in WP 0005.

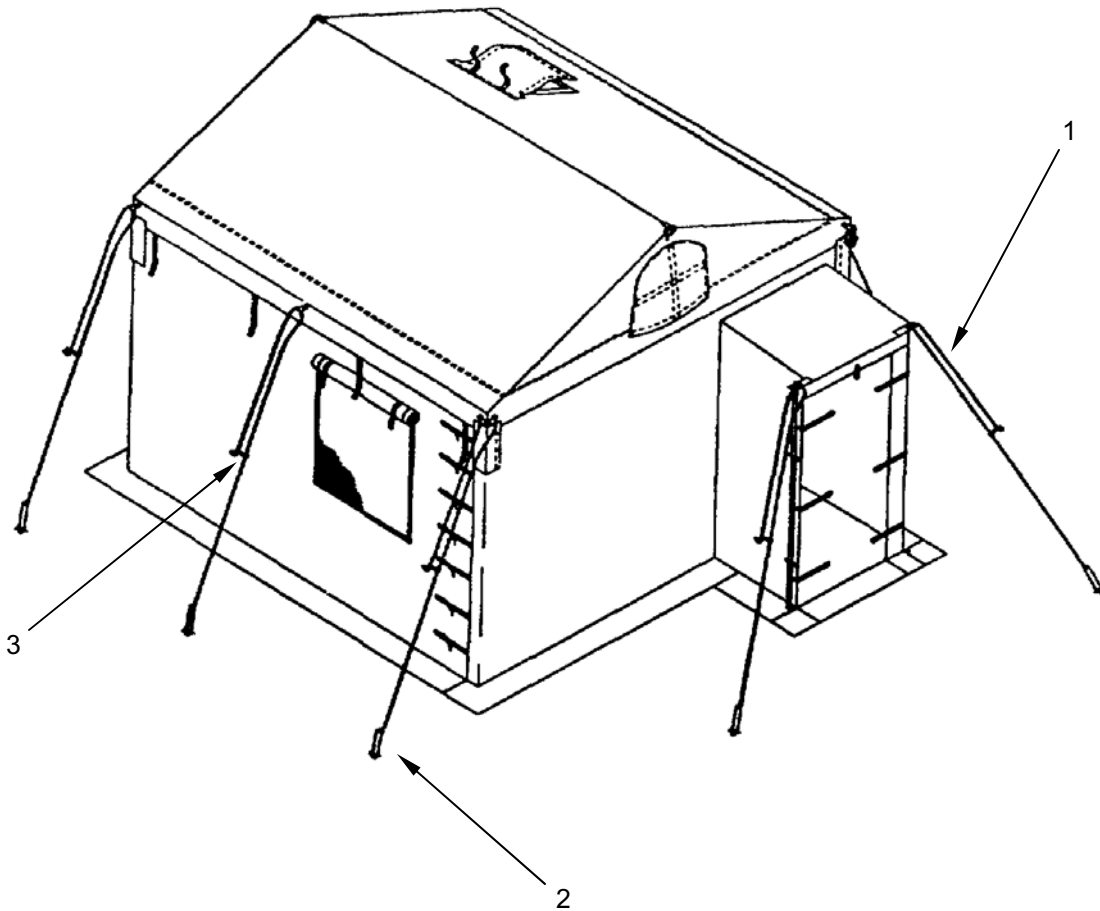

Figure 3. MCPS Will Not Stay Taut (Type I Shown).

SYMPTOM

Tent Lights Do Not Light.

MALFUNCTION

Disconnected power source (**Figure 4, Item 1**).

CORRECTIVE ACTION

Reconnect power to lights.



Figure 4. Tent Lights Do Not Light.

SYMPTOM

Field table not steady.

MALFUNCTION

Leg braces (Figure 5, Item 1) not fully extended or locked.

CORRECTIVE ACTION

Set up table IAW procedures given in WP 0005.

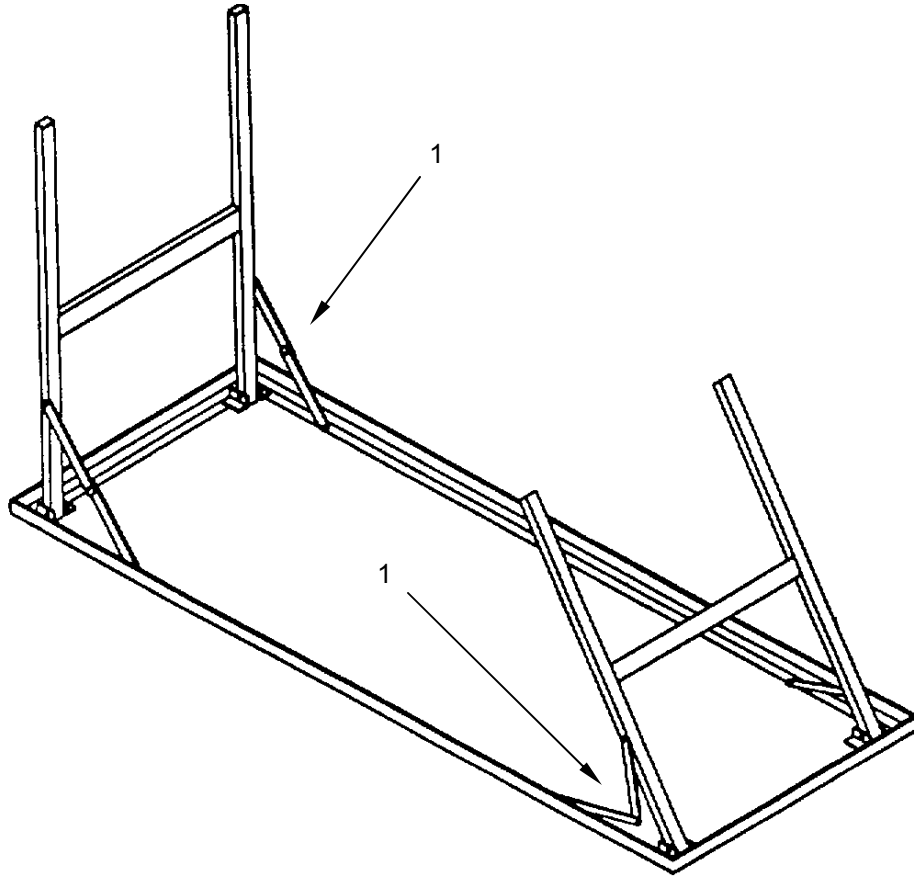

Figure 5. Field Table Not Steady.

END OF WORK PACKAGE

CHAPTER 5

PMCS MAINTENANCE INSTRUCTIONS
FOR
MODULAR COMMAND POST SYSTEM (MCPS), SMALL

**OPERATOR MAINTENANCE
MODULAR COMMAND POST SYSTEM (MCPS), SMALL
PREVENTATIVE MAINTENANCE CHECKS AND SERVICES (PMCS) INTRODUCTION**

INTRODUCTION

Preventive Maintenance Checks and Services (PMCS) are performed to keep the MCPS in good operating condition and ready for its primary mission. The checks are used to find, correct, and report problems. PMCS is performed every day the MCPS is in operation, and is done according to the PMCS table provided. Pay attention to **WARNING**, **CAUTION**, and **NOTE** statements. A **WARNING** indicates that someone could be hurt or killed. A **CAUTION** indicates that equipment could be damaged. A **NOTE** may make your maintenance or repair task easier.

Be sure to perform scheduled PMCS. Always perform PMCS in the same order so it becomes habit. With practice, you will quickly recognize problems with the equipment.

Use DA Form 2404, Equipment Inspection and Maintenance Worksheet, to record any discovered faults. Do not record faults that you fix!

PMCS PROCEDURES

Table 1 lists inspections and care required to keep your equipment in good operating condition. It is arranged so that you can perform before operation checks as you walk around the equipment.

Explanation of Table 1 Columns

Item No. Indicates the reference number. When completing DA Form 2404, Equipment Inspection and Maintenance Worksheet, include the item number for the item to check/service indicating a fault. Item numbers appear in the order you must perform the checks/services listed.

Interval. Indicates when you must perform the procedure in the procedure column.

- Before** - perform before equipment operation
- During** - perform during equipment operation
- After** - perform after equipment has been operated
- Weekly** - perform every week
- Monthly** - perform each month
- Hours** - perform at the noted hourly interval

Item to be Checked or Serviced. Indicates the item to be checked or serviced.

Procedure. Indicates the procedure you must perform on the item listed in Item to Check/Service column. You must perform the procedure at the time specified in the Interval column.

Equipment Not Ready/Available If. Indicates faults which will prevent your equipment from performing its primary mission. If you perform procedures listed in Procedure column which show faults listed in this column, do not operate the equipment. Follow standard procedures for maintaining the equipment or reporting equipment failure.

Other Special Entries. Observe all special information and notes that appear in Table 1. When a check/service procedure is required for both weekly and before intervals, it is not necessary to perform the procedure twice if the equipment is operated during the weekly period.

COMMON CHECKS AND CLEANING

Cleaning

Always keep the equipment clean. Remove dirt, sand, and debris from tent fabric and frame surfaces. Clean all MCPS fabric components with a brush and mild soapy water. Let fabric components air dry.

Bolts, Nuts, and Screws

Check bolts, nuts, and screws for obvious looseness, missing, bent, or broken condition on equipment. If you find a bolt, nut, or screw you think is loose, tighten it or report it to your supervisor.

CORROSION PREVENTION AND CONTROL

The MCPS tent system is designed to be corrosion resistant; however, tent components must never be stored wet or soiled in order to prevent possible corrosive damage to metal parts.

LEAKAGE DEFINITION FOR PERFORMING PMCS

It is necessary for you to know how fluid leakage affects the status of the equipment. The following are the types/classes of leakage an operator needs to know to be able to determine the status of the tent system. Learn these leakage definitions and remember - when in doubt, notify your supervisor.

CAUTION

Equipment operation is allowable with minor leakages (Class I or II). Consideration should be given to weather conditions, but when in doubt, notify your supervisor. Class III leaks should be reported immediately to your supervisor.

Class I - Seepage of fluid (as indicated by wetness or discoloration) not great enough to form drops.

Class II - Leakage of fluid great enough to form drops but not enough to cause drops to drip from item being checked/inspected.

Class III - Leakage of fluid great enough to form drops that fall from items being checked/inspected.

END OF WORK PACKAGE

**OPERATOR MAINTENANCE
MODULAR COMMAND POST SYSTEM (MCPS), SMALL
PREVENTATIVE MAINTENANCE CHECKS AND SERVICES (PMCS)**

INITIAL SETUP
Not Applicable

Table 1. Preventative Maintenance Checks and Services (PMCS).

ITEM NO.	INTERVAL	ITEM TO BE CHECKED OR SERVICED	PROCEDURE	EQUIPMENT NOT READY /AVAILABLE IF:
1	Before	Cables	Check for frayed cables (Figure 1, Item 1) or damage to swaged ends.	Cable assemblies frayed, damaged or missing.
2	Before, During, After	Frame Assemblies	<p style="text-align: center;">WARNING</p>  <p>When handling tent frame, do not grasp the frame near the frame joints. Failure to do so can result in personnel injury to hands and fingers.</p> <p>Check frame assembly components for damage, such as bends or missing handles (Figure 1, Item 2).</p> <p>Check release and locking mechanisms (Figure 1, Item 3) on legs and fittings for cracks and proper operation. Check fittings and connector (Figure 1, Item 4) on purlins for proper operation. Repair if necessary.</p> <p>Check condition of telescopic poles (Figure 1, Item 5). Look for bends or other damage to poles. Check for free movement.</p>	<p>Components damaged or missing.</p> <p>Inoperative release pins and locking handles.</p> <p>Telescopic poles bent or do not extend.</p>

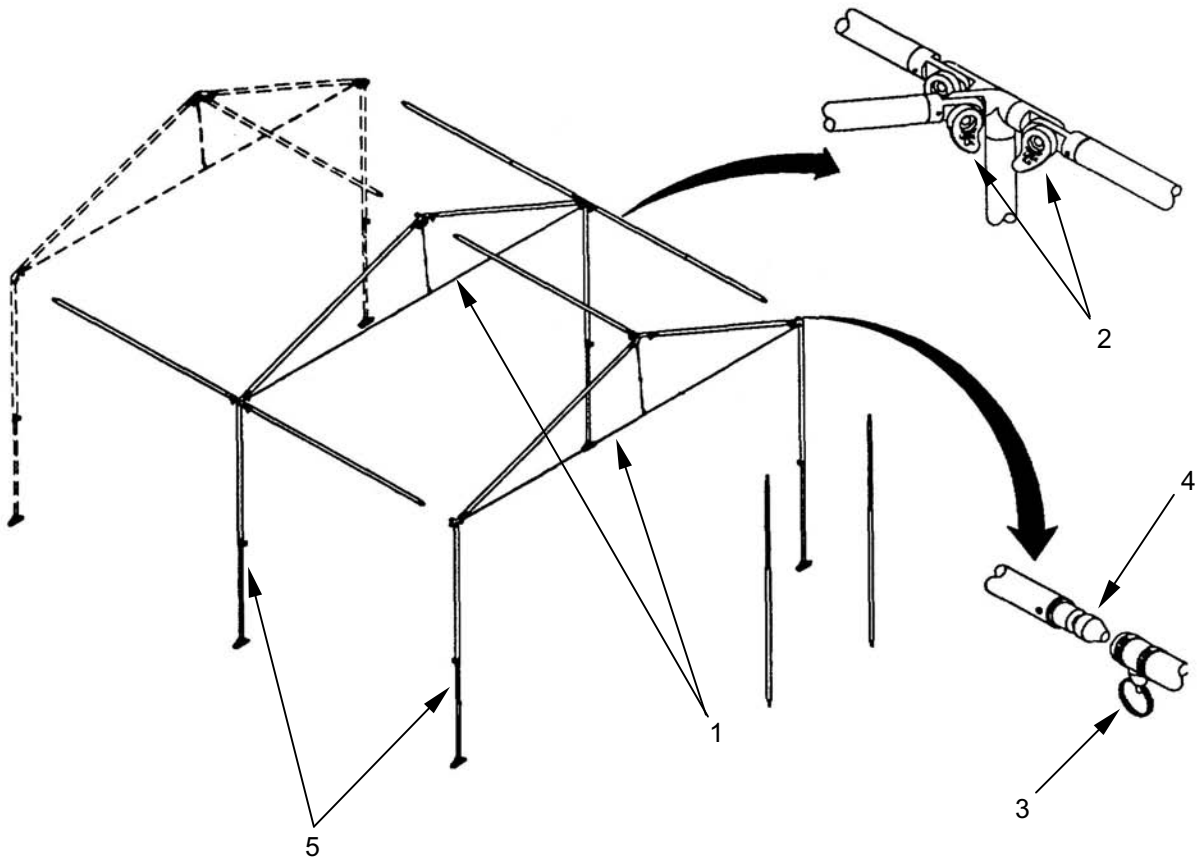

Figure 1. Frame Assembly PMCS.

Table 1. Preventative Maintenance Checks and Services (PMCS) - Continued.

ITEM NO.	INTERVAL	ITEM TO BE CHECKED OR SERVICED	PROCEDURE	EQUIPMENT NOT READY /AVAILABLE IF:
3	Before, During, After	Fabric Assemblies	Check fabric assemblies, including walls (Figure 2, Item 1), liners (Figure 2, Item 2), floor (Figure 2, Item 3), roof cap (Figure 2, Item 4), and gutters for rips, tears, missing straps, broken or missing grommets, or separating seams. Repair if necessary.	Fabric ripped or torn. Separated seams or fabric punctures. Roof cap leaking.
4	Before, During, After	Windows	Check windows (Figure 2, Item 5) for rips, tears, missing straps, punctured screens, or separated seams. Ensure window flaps are present, in good repair, and can be rolled up and secured. Repair if necessary.	Windows ripped or torn. Screens holed or torn. Separated seams or punctures. Missing or damaged flaps.
5	Before, During, After	Hook and Pile Fasteners	Inspect hook and pile fasteners (Figure 2, Item 6) for proper alignment and cleanliness. Remove dirt by brushing fastener strips	Fasteners do not hold when pressed together. Strips loose.
6	Before, After	Straps and Quick Disconnect Fasteners	Check interior and exterior straps (Figure 2, Item 7) and quick disconnect fasteners (Figure 2, Item 8) for fraying, tears, broken hardware.	Straps loose or missing. Fasteners broken.
7	Before, During, After	Tent Lines	Check tent lines (Figure 2, Item 9) for cuts and signs of mildew, excessive wear, or fraying.	Tent lines are cut, frayed, or excessively worn.
8	During	Tent Lines	Check for and tighten loose tent lines (Figure 2, Item 9).	Loose tent lines.
9	Before	Tent Line Slips	Inspect for broken tent line slips (Figure 2, Item 10).	Tent line slips broken or missing.
10	During	Tent Pins	Ensure all tent pins (Figure 2, Item 11) are present and in serviceable condition. Replace if necessary.	Missing or damaged tent pins.



Figure 2. Fabric Assemblies PMCS.

Table 1. Preventative Maintenance Checks and Services (PMCS) - Continued.

ITEM NO.	INTERVAL	ITEM TO BE CHECKED OR SERVICED	PROCEDURE	EQUIPMENT NOT READY /AVAILABLE IF:
11	Before	Table	Check hinges (Figure 3, Item 1) for smooth operation. Check for cracks or breaks in hinges and braces (Figure 3, Item 2).	Table does not fold or open. Bent or broken hinges or braces.
12	Before, During, After	Mapboard	Check for presence and condition of channel (Figure 3, Item 3) and locator assemblies (Figure 3, Item 4). Check for broken or scratched rollable and rigid overlays (Figure 3, Item 5).	Channel or locator assembly missing. Overlays damaged or otherwise not serviceable.

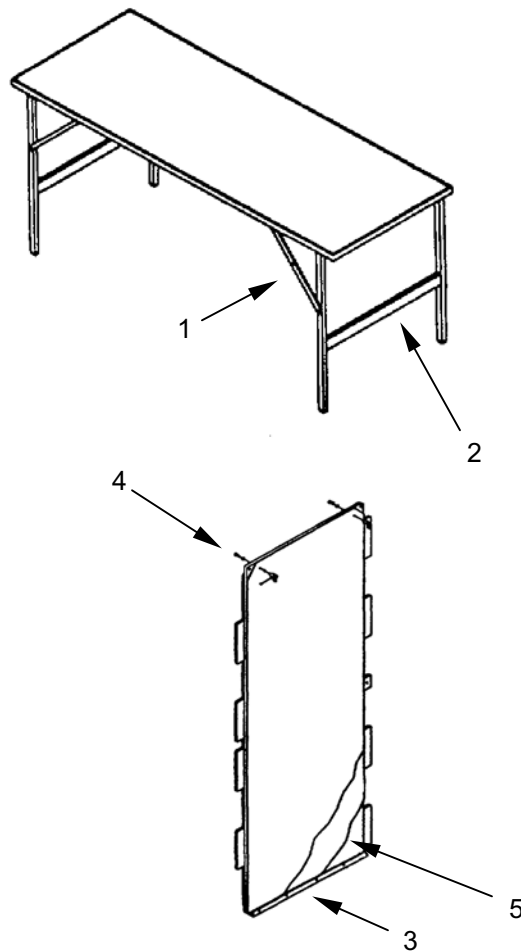



Figure 3. Table and Mapboard PMCS.

Table 1. Preventative Maintenance Checks and Services (PMCS) - Continued.

ITEM NO.	INTERVAL	ITEM TO BE CHECKED OR SERVICED	PROCEDURE	EQUIPMENT NOT READY /AVAILABLE IF:
13	Before, During, After	Light Set	<p style="text-align: center;">WARNING</p>  <p>Lethal voltage is present when light set is connected to power source. Disconnect from power source before inspecting or repairing any electrical component. Be careful not to contact electrical connections. Electrical shock and death may result from failure to heed this warning.</p> <p>Inspect light assembly (Figure 4, Item 1) for physical damage and cleanliness.</p> <p>Check male and female cable assemblies (Figure 4, Item 2) for physical damage to plug (Figure 4, Item 3) or insulation. If damaged, turn in to higher level maintenance.</p> <p>Check for security and proper functioning of ON/ OFF switch (Figure 4, Item 4) and lamp (Figure 4, Item 5). If damaged, turn in to higher level maintenance.</p>	<p>Light dirty or shows evidence of physical damage.</p> <p>Cables or plugs damaged or worn.</p> <p>Switch or lamp inoperative or malfunctioning.</p>
14	After	Light Set	Clean light assembly (Figure 4, Item 1) by wiping with dry cloth.	Lights dirty.
15	Before, After	Filter	Check filter (Figure 4, Item 6) for tears or punctures.	Light escapes through area other than designated opening.

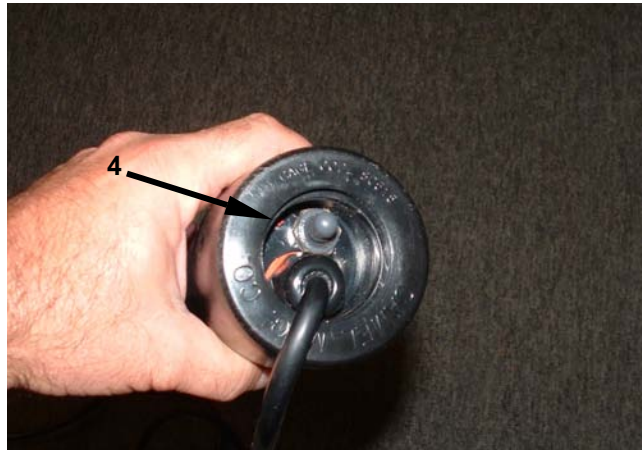
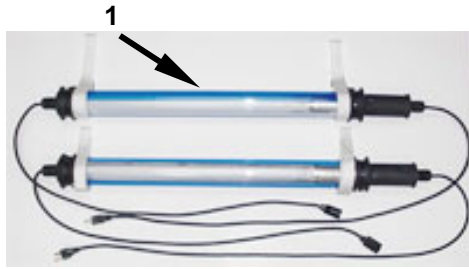
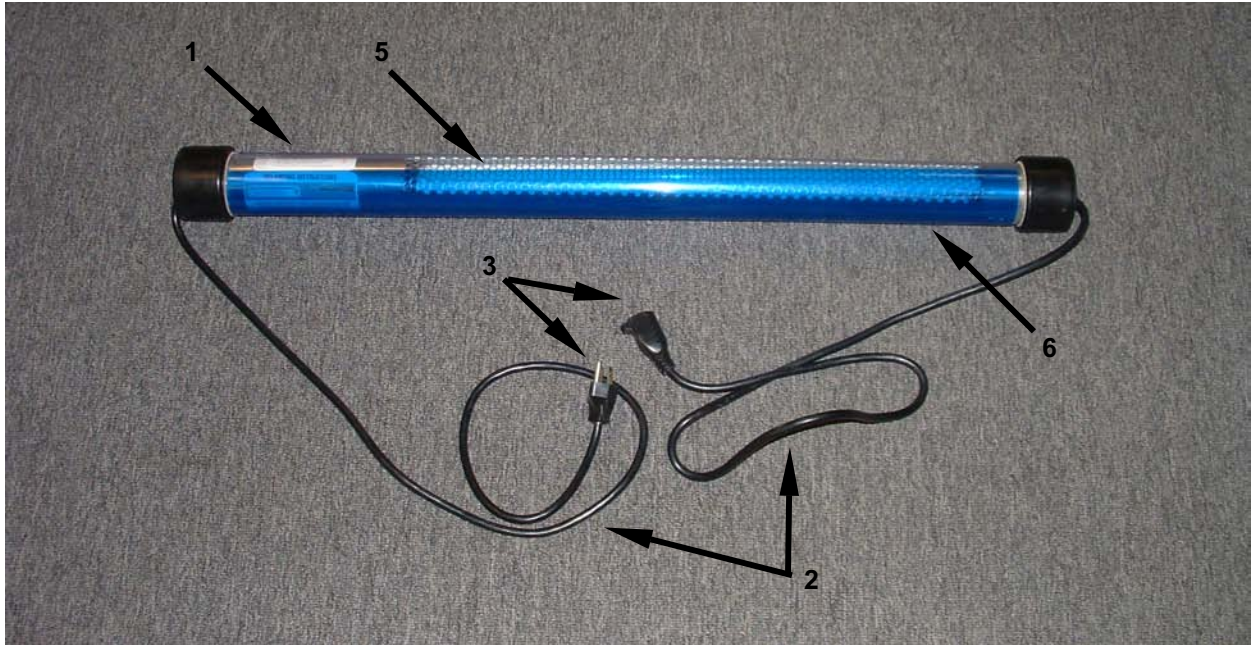

Figure 4. Light Set PMCS.

Table 1. Preventative Maintenance Checks and Services (PMCS) - Continued.

ITEM NO.	INTERVAL	ITEM TO BE CHECKED OR SERVICED	PROCEDURE	EQUIPMENT NOT READY /AVAILABLE IF:
16	Before, After	Transport Bags	Check frame (Figure 5, Item 1) and fabric (Figure 5, Item 2) transport bags and tent pin container (Figure 5, Item 3) for rips, tears or splitting seams. Check strap assemblies (Figure 5, Item 4) and carrying handles for fraying, missing hardware.	Bags are ripped. Straps are loose. Broken hardware. Handles ripped.



Figure 5. Transport Bags PMCS.

END OF WORK PACKAGE

CHAPTER 6

OPERATOR MAINTENANCE INSTRUCTIONS
FOR
MODULAR COMMAND POST SYSTEM (MCPS), SMALL

**OPERATOR MAINTENANCE
MODULAR COMMAND POST SYSTEM (MCPS), SMALL
SERVICE UPON RECEIPT**

INITIAL SETUP**Tools and Special Tools**

None Required

Personnel Required

One

Materials/Parts

None Required

References

FED-SPEC-PPP-B-601

Equipment Condition

Packed (WP 0005)

SERVICE UPON RECEIPT**Unpacking**

The MCPS components, will be packaged in a cleated plywood crate as per FED-SPEC-PPP-B-601, that is 75 inches long, 27 inches wide, and 42 inches deep. The box is strapped to a wooden pallet. Upon receipt, check for damage. Report any damage to the carrier and your supervisor.

CAUTION

Unpack components carefully. Improper or hasty handling may result in damage to the MCPS components and accessories.

1. Cut and remove retaining straps holding crate to pallet. Remove crate from wooden pallet.
2. Position crate to be unpacked with the top facing up.
3. Open the crate, remove packing material, and set it aside. Do not cut, rip, or otherwise damage the packing material.
4. Lift the components from the crate. Save the shipping crate and any packing material so it can be reused.

END OF TASK

Inspecting Unpacked Equipment

1. Check the equipment for damage incurred during shipment. Report any damage on DD Form 6, Packaging Improvement Report. Also note damage on DA Form 2404, Equipment Inspection and Maintenance Worksheet, and initiate corrective maintenance procedures.
2. Inspect the contents of the shipment against the packing slip and the Components of End Item (COEI) to see if any items are missing. Report any discrepancies noted in accordance with instructions in DA PAM 750-8. The equipment can be placed in service even if accessories, or other parts/assemblies that are not affecting proper functioning, are missing.
3. Check DA PAM 25-30 to see if there is any Maintenance Work Order (MWO) applicable to the MCPS components you are unpacking. If an MWO is listed, check to see if it has been applied to the equipment. The MWO number will be shown on the case/bag near the equipment nomenclature. If a current MWO is listed in DA PAM 25-30 but there is no evidence that it has been applied to the equipment you are unpacking, note discrepancy on DA Form 2404, Equipment Inspection and Maintenance Worksheet.

END OF TASK**END OF WORK PACKAGE**

**OPERATOR MAINTENANCE
TENT FABRIC ASSEMBLIES
REPAIR, REPLACE**

INITIAL SETUP**Tools and Special Tools**

Tentage Repair Kit (WP 0046, Item 4)

Personnel Required

One

Materials/Parts

Wood dunnage

ReferencesWP 0005, WP 0006
FM 10-16**Equipment Condition**

MCPS set up and lighting installed (WP 0005)

REPAIR**Repair Tent Fabric Assemblies with Adhesive Patch Application**

CAUTION

Do not use adhesive patch repair on insulated liners. The patch will not adhere correctly, and the use of adhesive may damage the liner material. Use hand stitched patches if necessary, or contact Unit Maintenance.

1. Repairs to the tent fabric assemblies will be limited to rips and tears or holes not exceeding 6 inches. Use the tentage repair kit to accomplish the repair. Consult FM 10-16 for specific guidelines of tentage repair.
2. Although the fabric assemblies can be repaired during operational use when necessary, it is recommended that the fabric be repaired when the tent is not in use. The fabric assemblies should be clean and dry.
3. Obtain a clean, round patch (**Figure 1, Item 1**) from bulk material or salvage that is at least 1 inch larger than the damaged fabric area (**Figure 1, Item 2**) in all directions.
4. Place the damaged fabric area (**Figure 1, Item 2**) on a flat surface, or place a piece of softwood (or similar) under the damaged fabric area.
5. Center patch (**Figure 1, Item 1**) over damaged fabric area (**Figure 1, Item 2**). Draw a circle on fabric around patch, then remove patch.
6. Clean damaged fabric area (**Figure 1, Item 2**) inside circle.

WARNING

The adhesive has a high alcohol content and is highly flammable. Use only in well ventilated areas away from open flame. Do not smoke. In case of dizziness, leave area immediately and allow to ventilate. Failure to observe this warning may result in severe injury or death.

7. Place patch (**Figure 1, Item 2**) face-down over circle. Coat patch evenly with adhesive (**Figure 1, Item 3**), allowing adhesive to overlap onto fabric to form an adhesive circle. Remove patch and set aside with adhesive side up.
8. Coat damaged fabric area (**Figure 1, Item 2**) with adhesive (**Figure 1, Item 3**) inside circle. Allow adhesive on patch (**Figure 1, Item 1**) and adhesive circle to dry.
9. Apply a second coat of adhesive (**Figure 1, Item 3**) to patch (**Figure 1, Item 1**) and inside adhesive circle.
10. Wait ten to fifteen minutes for adhesive (**Figure 1, Item 3**) to become tacky to touch.
11. Center patch (**Figure 1, Item 1**) over circle, adhesive side down, and press the two sticky surfaces together.
12. Using hand roller (**Figure 1, Item 4**), press excess adhesive and air bubbles from under patch (**Figure 1, Item 1**). Roll first in one direction, then in opposite direction.
13. Using tongue depressor (**Figure 1, Item 5**), apply a small amount of adhesive (**Figure 1, Item 3**) to edge of patch.
14. Run tongue depressor (**Figure 1, Item 5**) around patch (**Figure 1, Item 1**) to seal and prevent fraying.
15. Allow adhesive (**Figure 1, Item 3**) to dry at least 30 minutes before placing damaged component back in service.

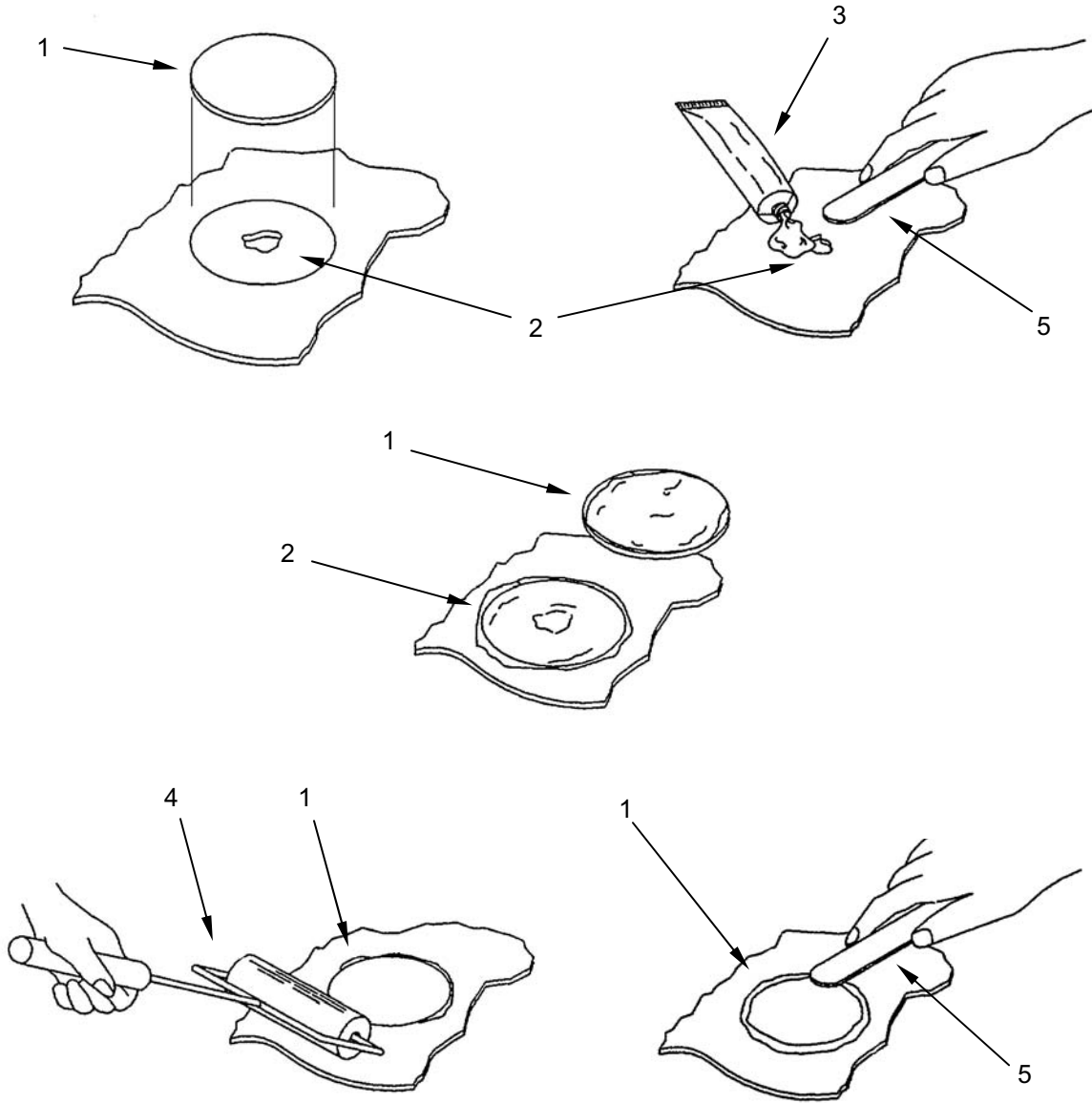

Figure 1. Repair Tent Fabric Assemblies with Adhesive Patch Application.

END OF TASK

Repair Tent Fabric Assemblies with Hand Stitched Patch Application

1. Although the fabric assemblies can be repaired during operational use when necessary, it is recommended that the fabric be repaired when the tent is not in use. The fabric assemblies should be clean and dry.

NOTE

If you use two-strand thread you will need twice as much; if you use four-strand, you will need four times as much.

2. Estimate amount of thread (**Figure 2, Item 1**) required to complete stitching and cut thread to length.
3. Wax thread (**Figure 2, Item 1**) by pressing between thumb and beeswax (**Figure 2, Item 2**) and drawing entire length over beeswax .
4. Thread sailmaker's needle (**Figure 2, Item 3**) with waxed thread (**Figure 2, Item 1**) to form a single, two-, or four-strand thread as follows:
 - a. Single. Form a small loop (**Figure 2, Item 4**) near one end and push the loop through the eye of the needle (**Figure 2, Item 3**).
 - b. Two-strand. To make a double strand thread, pull the thread (**Figure 2, Item 1**) through the needle (**Figure 2, Item 3**) until the needle is at the midpoint of the single thread strand.
 - c. Four-strand. To form four-strand thread, bend a length of thread in half and insert the loop end (**Figure 2, Item 5**) into the eye of the needle (**Figure 2, Item 3**), pulling it through so that the eye is at the midpoint of the double strand of thread.
 - d. Twist the strands together and rewax the entire length of thread (**Figure 2, Item 1**).
5. Tie knot at far end of the single, two-, or four-strand thread (**Figure 2, Item 1**).

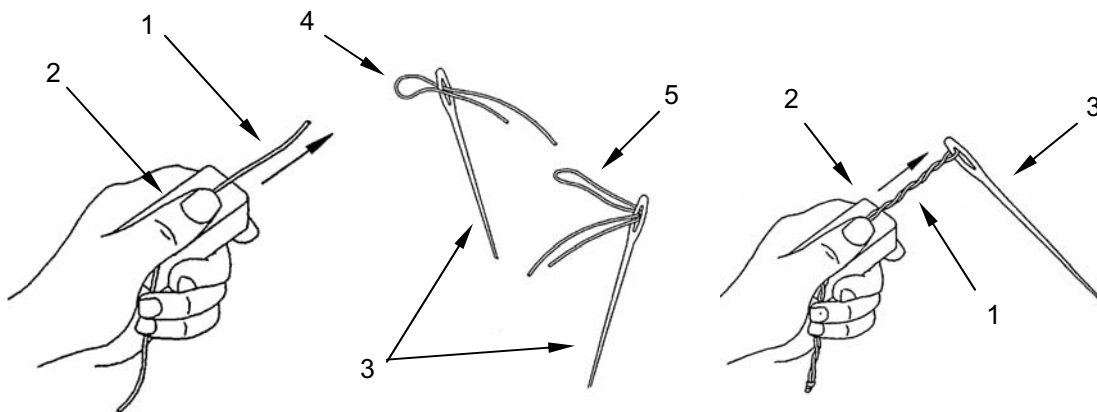

Figure 2. Repair Tent Fabric Assemblies with Hand Stitched Patch Application.

6. Hand stitches. There are five common hand stitches used to mend fabric in different situations. Choose the one that most closely resembles the repair you are making.
 - a. Flat Stitch (**Figure 3, Item 1**). This stitch is used as a temporary fastening until machine repairs can be made. Pass the needle over and under an equal amount of material, each successive entering the material from the opposite side.
 - b. Round Stitch (**Figure 3, Item 2**). This stitch is used to hand-work grommets. Insert the materials at right angles to the edge of material and bring cord around edge before making the next stitch.
 - c. Overcast Stitch (**Figure 3, Item 3**). This stitch is used to apply a hand-sewn patch. Insert the needle through the material at an angle so that it comes out to one side and ahead of the point of insertion, and bring the cord over to the original line of insertion before making the next stitch.
 - d. Backstitch (**Figure 3, Item 4**). This stitch is used to secure an open seam. It is so named because the needle is always set back one half of a stitch length into the last stitch made. Make two small stitches in the same place to secure the cord ends. Continue by inserting the needle into the middle of the preceding stitch and bringing it out on the same side of the material one stitch length in advance of the preceding stitch.
 - e. Fishbone Stitch (**Figure 3, Item 5**). This stitch is used to join edges of a tear until a patch can be applied. Insert needle between two edges of material to be sewn together. Take a diagonal stitch from one side toward the other, bringing the needle out between the two edges. Repeat this operation on the opposite side, and continue alternating stitches from side to side. To keep the stitches uniform, hold the edges smoothly together. Make stitches firmly, but do not pull them tight enough to pucker the fabric.

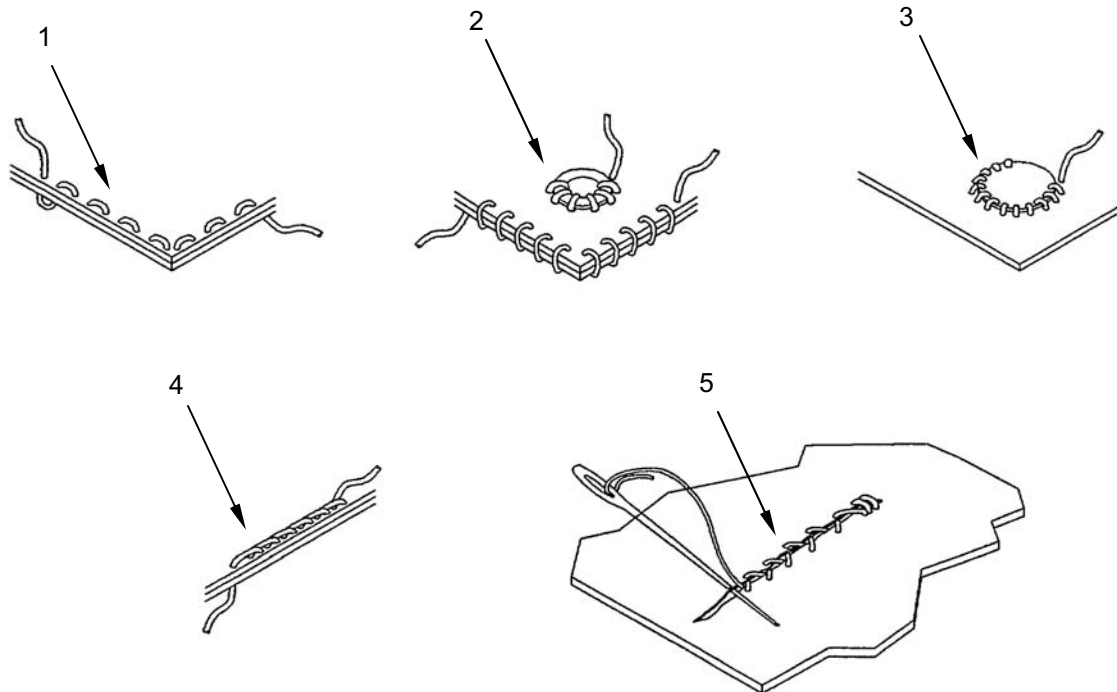

Figure 3. Hand Stitches.

END OF TASK

Replace a Die-Inserted Grommet

A die-inserted grommet (**Figure 4, Item 1**) consists of two brass parts. The male half, called a barrel (**Figure 4, Item 2**), is smooth. The female half, called a washer (**Figure 4, Item 3**), has spurs that grip the fabric.

1. Position fabric (**Figure 4, Item 4**) face up on end grain surface of softwood lumber.
2. Using a size 5 cutting punch (**Figure 4, Item 5**) for a size 4 grommet (or a size 6 cutting punch for a size 5 grommet) and a rawhide mallet (**Figure 4, Item 6**), cut a grommet hole in the fabric by hitting top of cutting punch with rawhide mallet.
3. Insert grommet barrel (**Figure 4, Item 2**) into hole of fabric (**Figure 4, Item 4**) from the underside.
4. Place fabric (**Figure 4, Item 4**) and bottom (flat) part of grommet barrel (**Figure 4, Item 2**) on grommet die (**Figure 4, Item 7**).
5. Place the grommet washer (**Figure 4, Item 3**), spurs down, over grommet barrel (**Figure 4, Item 2**).
6. Insert cutting punch (**Figure 4, Item 5**) into grommet barrel (**Figure 4, Item 2**) and hold in place.
7. Hit top of cutting punch (**Figure 4, Item 5**) with rawhide mallet (**Figure 4, Item 6**) hard enough to clinch the parts to fabric (**Figure 4, Item 4**) without damaging grommet (**Figure 4, Item 1**) or fabric. When parts are clinched properly, the edge of the grommet barrel (**Figure 4, Item 2**) has a smooth roll.

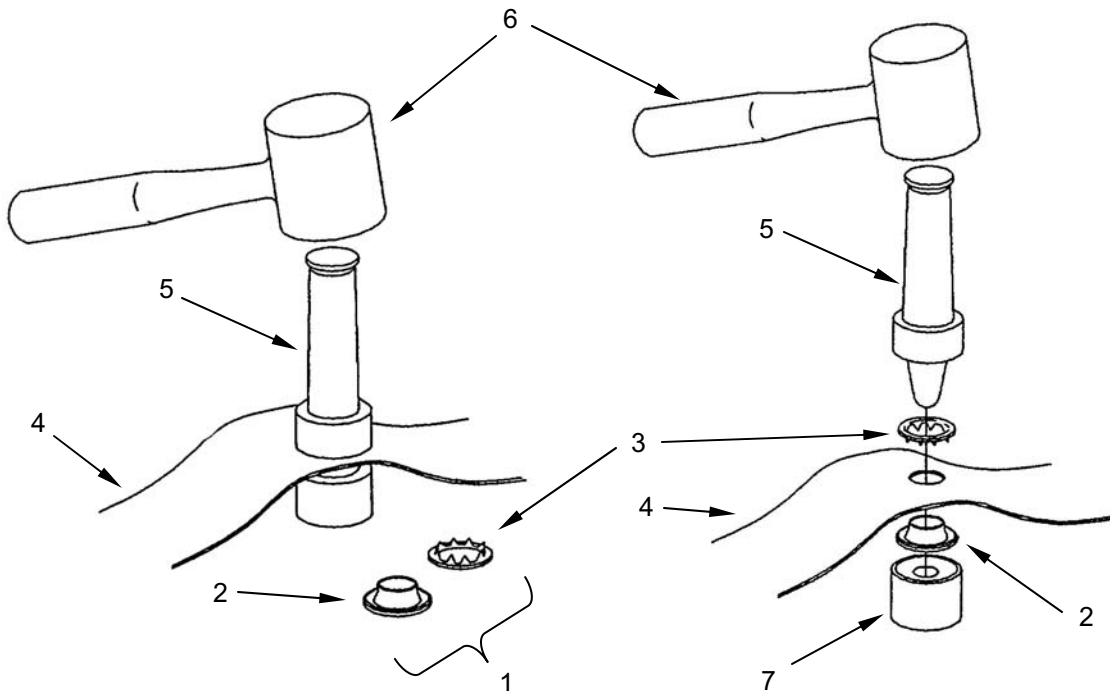

Figure 4. Replace a Die-Inserted Grommet.

END OF TASK

Repair Webbing and Buckles

NOTE

It is not necessary to replace an entire piece of webbing when only a small portion is damaged and webbing does not need to be threaded through a buckle for adjustment. The damaged area can be cut out and replaced, leaving a portion of the original piece in place.

1. Identify the webbing (**Figure 5, Item 1**) or buckle (**Figure 5, Item 2**) component that is damaged and obtain a replacement, or fabricate one from bulk or serviceable salvage stocks. For fixed webbing pieces, add an inch to length of replacement piece.
2. Remove unserviceable webbing (**Figure 5, Item 1**) or buckle (**Figure 5, Item 2**) from assembly. Undamaged components should be removed and salvaged wherever possible.
3. Assemble and sew buckles (**Figure 5, Item 2**) and webbing (**Figure 5, Item 1**) as required to form new assemblies.
4. Position webbing (**Figure 5, Item 1**) and buckle (**Figure 5, Item 2**) assemblies on tent fabric and sew. For fixed webbing pieces, overlap each end by $\frac{1}{2}$ inch.

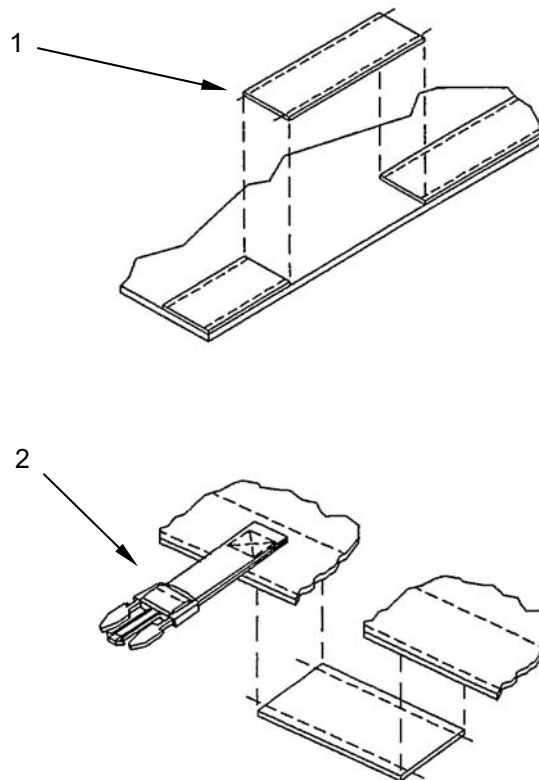

Figure 5. Repair Webbing and Buckles.

END OF TASK

REPLACE**Replace Fabric Assemblies**

Replace any fabric assembly which has rips or tears greater than 12 inches in length. Refer to WP 0005 and WP 0006 for instructions on how to remove and install fabric assemblies.

END OF TASK**END OF WORK PACKAGE**

**OPERATOR MAINTENANCE
LIGHT SET
REPAIR**

INITIAL SETUP**Tools and Special Tools**

None Required

Personnel Required

One

Materials/Parts

None Required

References

None Required

Equipment Condition

MCPS set up and lighting installed (WP 0005)

REPLACE**NOTE**

Lamp P/N 5-4-8194 cannot be repaired at Field Maintenance level.

Replace Lamp (P/N 31-502SK, F131-502SK, F131-5004, MIL-PRF-44259 TYPE II, and similar only)

WARNING

Turn off power before performing any maintenance on the light assembly. Lethal voltage is present when power is applied to light. Electrical shock and death may result from failure to heed this warning.

NOTE

A step aid may be required to remove the light from the straps.

1. Turn light OFF at switch (**Figure 1, Item 1**) and disconnect power connection (**Figure 1, Item 2**). Remove light from straps (**Figure 1, Item 3**).



Figure 1. Remove Light Assembly.

2. Remove strain relief nut (**Figure 2, Item 4**) from smaller end cap located opposite handle, then remove end cap (**Figure 2, Item 5**). Do not loosen jam nut (**Figure 2, Item 6**).

NOTE

It may be necessary to cut cable ties retaining the end cap.

3. Carefully remove shock (**Figure 2, Item 7**), using care not to pull on cord (**Figure 2, Item 8**).

WARNING



If the lamp has shattered within the light assembly, use caution when clearing the glass from the lamp. Glass shards can cause severe cuts to fingers, and the fluorescent coating of the bulb may be accidentally inhaled or ingested.

4. Grasp bulb puller (**Figure 2, Item 9**) and gently but firmly pull bulb (**Figure 2, Item 10**) out of socket and remove from outer tube (**Figure 2, Item 11**). Take care since bulb is tightly wedged in socket.
5. Remove bulb puller (**Figure 2, Item 9**) from old bulb (**Figure 2, Item 10**) and dispose of bulb IAW unit SOP. If old bulb is not broken, there is a vacuum inside and breaking the bulb can be dangerous.
6. Clean inside of outer tube (**Figure 2, Item 11**) if necessary.
7. Install bulb puller (**Figure 2, Item 9**) on replacement bulb (**Figure 2, Item 10**) as shown. This will assist in removing bulb the next time.
8. Slide the replacement bulb (**Figure 2, Item 10**) with bulb puller (**Figure 2, Item 9**) into outer tube and align so pins (**Figure 2, Item 12**) will intersect with receiver holes in socket.
9. Gently push bulb (**Figure 2, Item 10**) down into socket and seat pins (**Figure 2, Item 12**) in receiver holes.
10. Plug light in and activate switch. Ensure bulb (**Figure 2, Item 10**) is seated properly and that it illuminates. Switch light OFF and disconnect power.
11. Replace shock (**Figure 2, Item 7**), using care not to pull on cord (**Figure 2, Item 8**) or screen.
12. Replace end cap (**Figure 2, Item 5**), making certain cap is fully seated in groove of tube. Secure in place with cable tie, if necessary.
13. Install and tighten strain relief nut (**Figure 2, Item 4**).
14. Install light IAW procedures given in WP 0005.

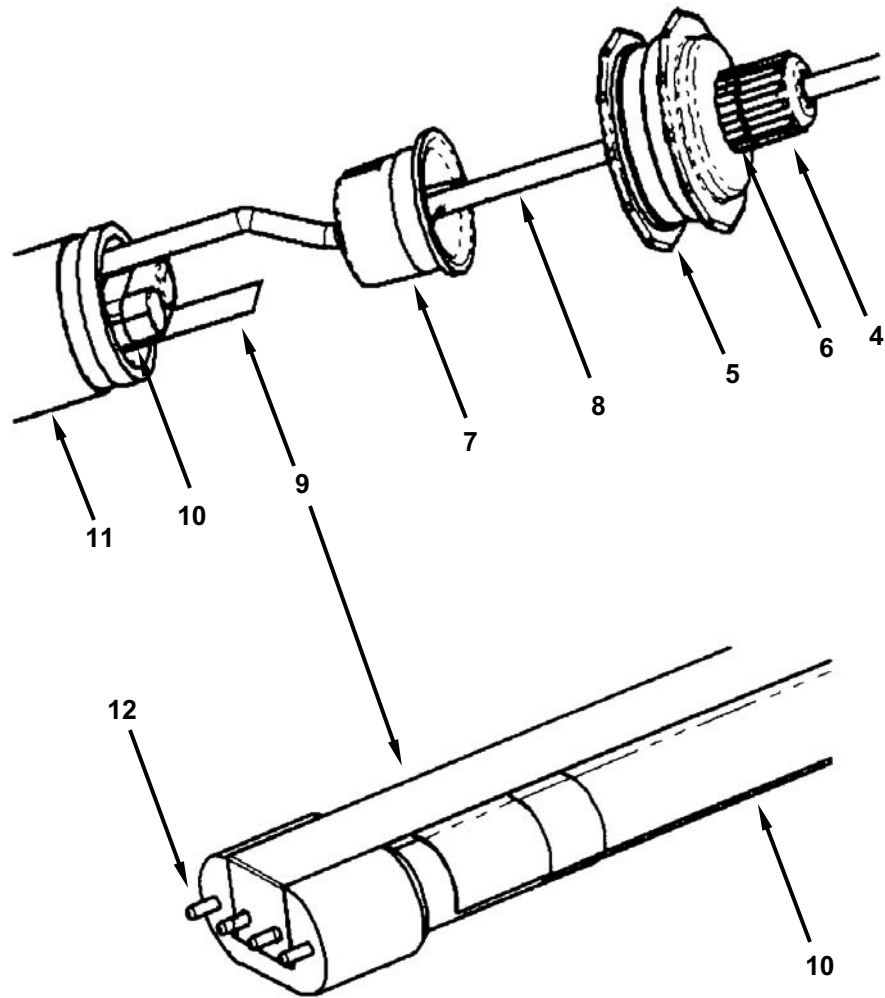

Figure 2. Replace Lamp.

END OF TASK

END OF WORK PACKAGE

CHAPTER 7
UNIT MAINTENANCE INSTRUCTIONS
FOR
MODULAR COMMAND POST SYSTEM (MCPS), SMALL

**UNIT MAINTENANCE
FRAME ASSEMBLY**
REPAIR, REPLACE**INITIAL SETUP****Tools and Special Tools**

Tool Kit, General Mechanic's (WP 0046, Item 7)

Personnel Required

One

Materials/Parts

Lower Leg Assembly (WP 0019, Items 5, 23)
 Handle (WP 0019, Items 15, 37)
 Rafter Assembly (WP 0019, Items 8, 29)
 Upper Leg Assembly (WP 0019, Items 4, 22)
 Purlin (WP 0019, Items 17, 18, 31)
 Detent Assembly (WP 0019, Items 6, 10, 25, 33)
 Cable Assembly (WP 0019, Items 19, 39)
 Cord (WP 0019, Items 20, 40)

References

WP 0016
 WP 0005

Equipment Condition

MCPS struck (WP 0005)
 Frame Sections separated (WP 0005)

REPAIR**Repair a Handle, Rafter Assembly, Upper Leg Assembly, or Purlin**

WARNING



When handling tent frame, do not grasp the frame near the frame joints. Failure to do so can result in personnel injury to hands and fingers. Failure to follow tie down and staking instructions may result in possible injury to personnel and damage to equipment.

CAUTION

Support assemblies during removal/replacement to prevent damage. There is a spring inside the fitting assembly. Be careful not to lose it when disassembling the fitting.

NOTE

Remove/replace procedures for the handles are identical, regardless of the assembly on which they are used.

1. Turn handle (**Figure 1, Item 1**) to the unlocked position and keep it there.
2. Without allowing bolt (**Figure 1, Item 2**) to rotate, remove nut (**Figure 1, Item 3**).

3. Unscrew bolt (**Figure 1, Item 2**) from front of fitting (**Figure 1, Item 4**) and remove.
4. Remove handle (**Figure 1, Item 1**) from fitting (**Figure 1, Item 4**). If removing handle only, proceed with replace procedures.
5. Separate front (**Figure 1, Item 4**) and rear (**Figure 1, Item 5**) sections of the fitting, being careful not to lose spring (**Figure 1, Item 6**).
6. If replacing rafter assemblies (**Figure 1, Item 7**), repeat above steps 1. through 5. for second fitting.
7. If replacing upper leg assemblies (**Figure 1, Item 8**), pull ring on detent assembly (**Figure 1, Item 9**) to release lower leg assembly (**Figure 1, Item 10**).
8. Remove lower leg assembly (**Figure 1, Item 10**) and allow detent (**Figure 1, Item 9**) to snap back into place.
9. Insert bolt (**Figure 1, Item 2**) through handle (**Figure 1, Item 1**) and front of fitting (**Figure 1, Item 4**). Place spring (**Figure 1, Item 6**) over bolt, ensuring that it is properly seated. Thread bolt through rear of fitting (**Figure 1, Item 5**).
10. Align teeth of fitting (**Figure 1, Item 5**) crown-to-crown (not nested or engaged).
11. Turn handle (**Figure 1, Item 1**) to completely unlocked position and keep it there.
12. Keeping teeth in crown-to-crown position, turn bolt (**Figure 1, Item 2**) until it bottoms.
13. Back off bolt (**Figure 1, Item 2**) $\frac{1}{2}$ turn to allow $\frac{1}{32}$ - inch folding clearance.
14. Place nut (**Figure 1, Item 3**) on bolt (**Figure 1, Item 2**) and tighten without allowing bolt to rotate.
15. Check fitting (**Figure 1, Item 5**) for proper assembly as follows:
 - a. Rotate handle (**Figure 1, Item 1**) to fully unlocked position. At this point there should be $\frac{1}{32}$ - inch rotation clearance.
 - b. Rotate handle (**Figure 1, Item 1**) to fully locked position. At this point handle should be at 90 degrees to purlin (**Figure 1, Item 11**) and/or rafter (**Figure 1, Item 7**).
16. For rafter assemblies (**Figure 1, Item 7**), repeat above steps 7. through 15. for second fitting.
17. For upper leg assemblies (**Figure 1, Item 8**), pull ring on quick release assembly (**Figure 1, Item 9**) and insert lower leg assembly (**Figure 1, Item 10**), lining up holes. Allow quick release to snap back into place.

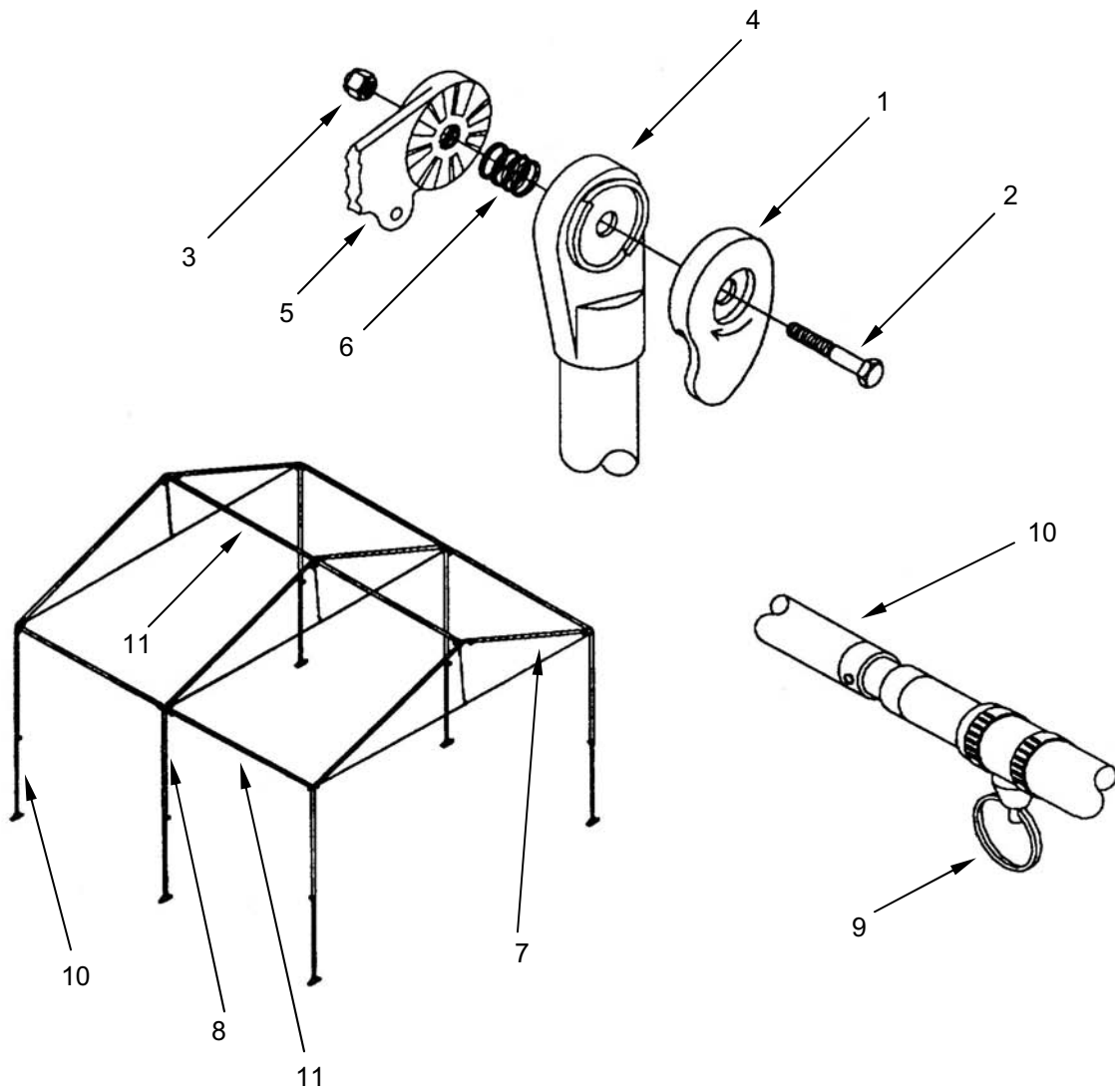

Figure 1. Repair Handle, Rafter Assembly, Upper Leg Assembly, or Purlin.

END OF TASK

REPLACE**Replace Frame Lower Leg Assemblies****WARNING**

When handling tent frame, do not grasp the frame near the frame joints. Failure to do so can result in personnel injury to hands and fingers. Failure to follow tie down and staking instructions may result in possible injury to personnel and damage to equipment.

1. Remove lower leg assembly (**Figure 2, Item 1**) by pulling ring (**Figure 2, Item 2**) on detent assembly (**Figure 2, Item 3**), releasing lower leg assembly from upper leg assembly (**Figure 2, Item 4**).
2. Insert replacement lower leg assembly (**Figure 2, Item 1**) into upper leg assembly (**Figure 2, Item 4**), and lock with detent (**Figure 2, Item 3**) to the desired height.

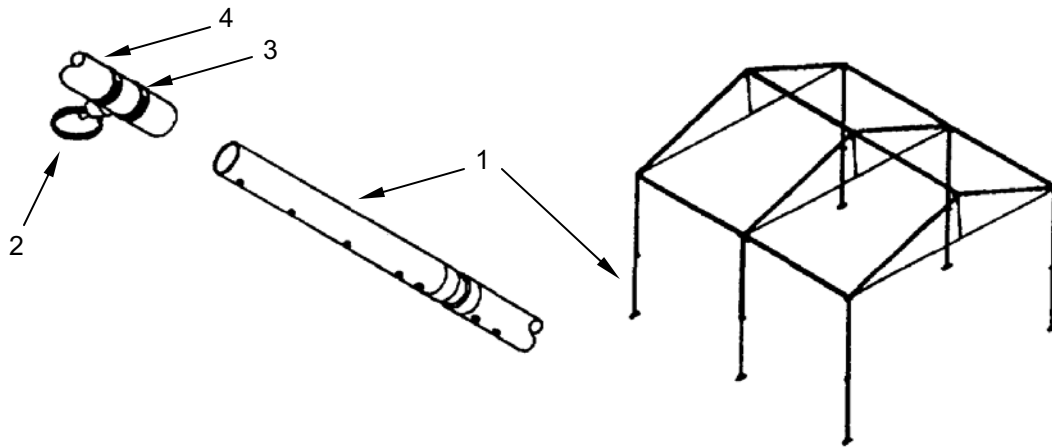

Figure 2. Replace Frame Lower Leg Assemblies.

END OF TASK

Replace Detent Assemblies

WARNING



When handling tent frame, do not grasp the frame near the frame joints. Failure to do so can result in personnel injury to hands and fingers. Failure to follow tie down and staking instructions may result in possible injury to personnel and damage to equipment.

1. Loosen and remove two worm gear clamps (**Figure 3, Item 1**) securing detent assembly (**Figure 3, Item 2**).
2. Remove detent assembly (**Figure 3, Item 2**).

CAUTION

Do not overtighten worm gear clamps.

3. Position detent assembly (**Figure 3, Item 2**), with channels for worm gear clamps (**Figure 3, Item 1**) parallel to end of frame member or fitting (**Figure 3, Item 3**).
4. Position two worm gear clamps (**Figure 3, Item 1**) around frame member (**Figure 3, Item 3**) and detent assembly (**Figure 3, Item 2**). Ensure that clamps are placed in channels in detent assembly.
5. Alternately tighten worm gear clamps (**Figure 3, Item 1**) until detent assembly (**Figure 3, Item 2**) is securely attached to tube or fitting.

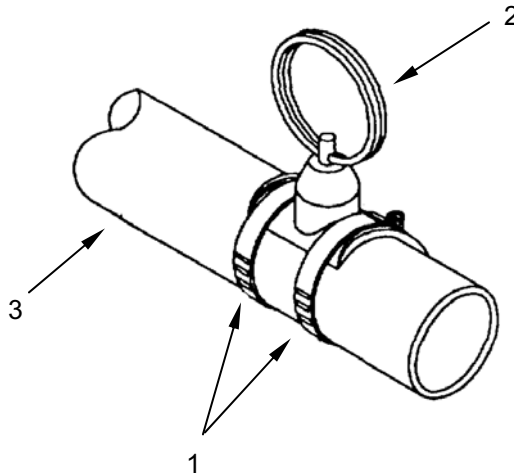

Figure 3. Replace Detent Assembly.

END OF TASK

Replace Cable Assemblies

WARNING



When handling tent frame, do not grasp the frame near the frame joints. Failure to do so can result in personnel injury to hands and fingers. Failure to follow tie down and staking instructions may result in possible injury to personnel and damage to equipment.

1. Remove bolt (**Figure 4, Item 1**) and locknut (**Figure 4, Item 2**) securing cable assembly (**Figure 4, Item 3**) to upper leg assembly fitting (**Figure 4, Item 4**).
2. Pull cable assembly (**Figure 4, Item 3**) out of cord (**Figure 4, Item 5**) loop.
3. If removing cord (**Figure 4, Item 5**), slide cord off purlin (**Figure 4, Item 6**).
4. Insert cable assembly (**Figure 4, Item 3**) through cord (**Figure 4, Item 5**) loop.
5. Align swaged end of cable assembly (**Figure 4, Item 3**) with hole in upper leg assembly fitting (**Figure 4, Item 4**) and install bolt (**Figure 4, Item 1**) and locknut (**Figure 4, Item 2**).
6. If replacing cord, slide cord (**Figure 4, Item 5**) loop over purlin (**Figure 4, Item 6**).

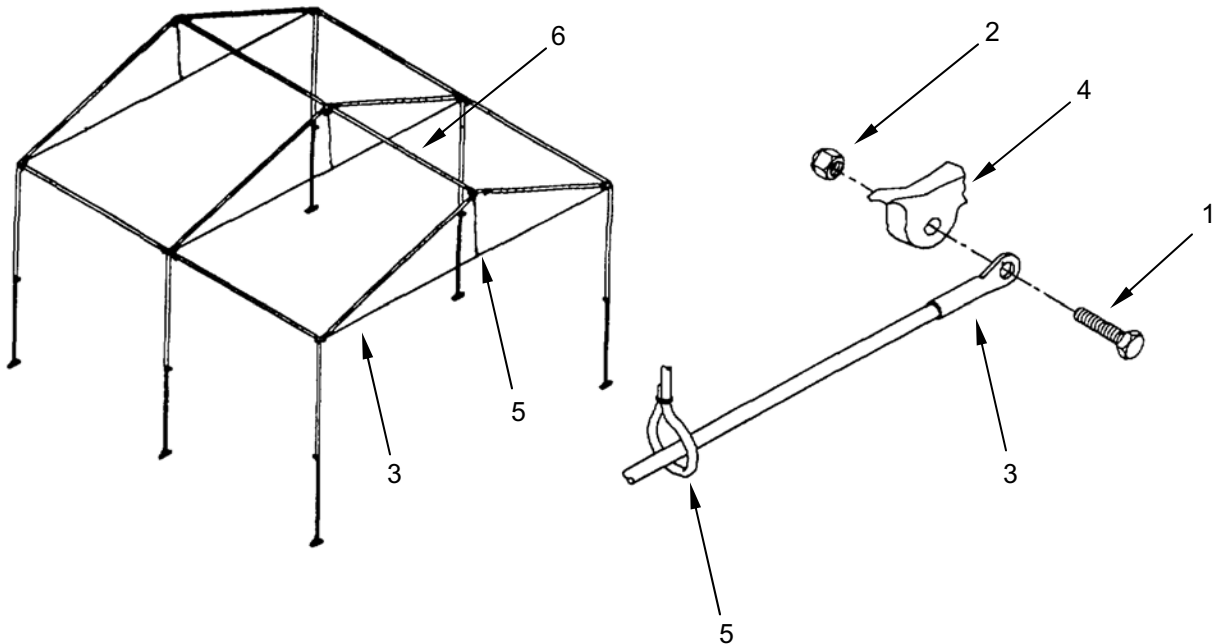

Figure 4. Replace Cable Assemblies.

END OF TASK

END OF WORK PACKAGE

**UNIT MAINTENANCE
MAPBOARD ASSEMBLY
REPAIR, REPLACE**

INITIAL SETUP**Tools and Special Tools**

Tool Kit, General Mechanic's
(WP 0046, Item 7)

Personnel Required

One

Materials/Parts

Locator Cylinder Assembly (WP 0035, Item 4)
Overlay, Rigid (WP 0035, Item 16)
Overlay, Rollable (WP 0035, Item 17)

References

WP 0005

Equipment Condition

Mapboards separated (WP 0005)

REPAIR**Repair Mapboard Assembly**

1. Remove screw (**Figure 1, Item 1**) holding locator assembly (**Figure 1, Item 2**) to mapboard panel (**Figure 1, Item 3**).
2. Remove locator cylinder assembly (**Figure 1, Item 2**).
3. Insert replacement locator cylinder assembly (**Figure 1, Item 2**) through rollable overlay (**Figure 1, Item 4**), rigid overlay (**Figure 1, Item 5**), and mapboard panel (**Figure 1, Item 3**).
4. Install screw (**Figure 1, Item 1**) holding locator cylinder assembly (**Figure 1, Item 2**) to mapboard panel (**Figure 1, Item 3**).
5. Move cylinder locator (**Figure 1, Item 2**) into horizontal position.
6. Remove rollable (**Figure 1, Item 4**) and/or rigid (**Figure 1, Item 5**) overlays.
7. Place replacement rigid (**Figure 1, Item 5**) and/or rollable (**Figure 1, Item 4**) overlays over cylinder locator (**Figure 1, Item 2**).
8. Move cylinder locator (**Figure 1, Item 2**) into vertical position.

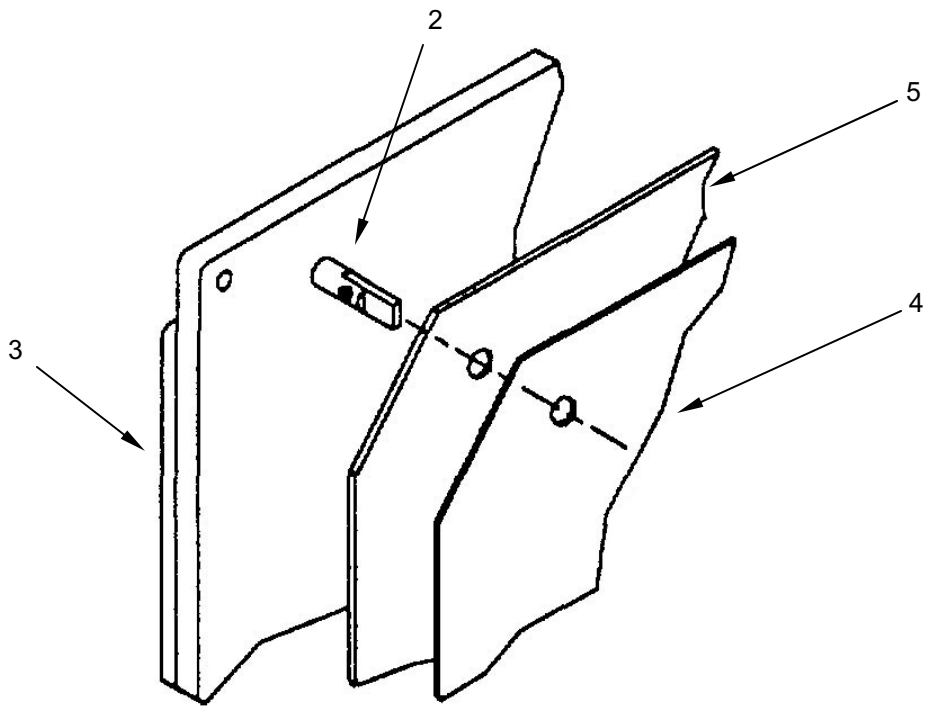
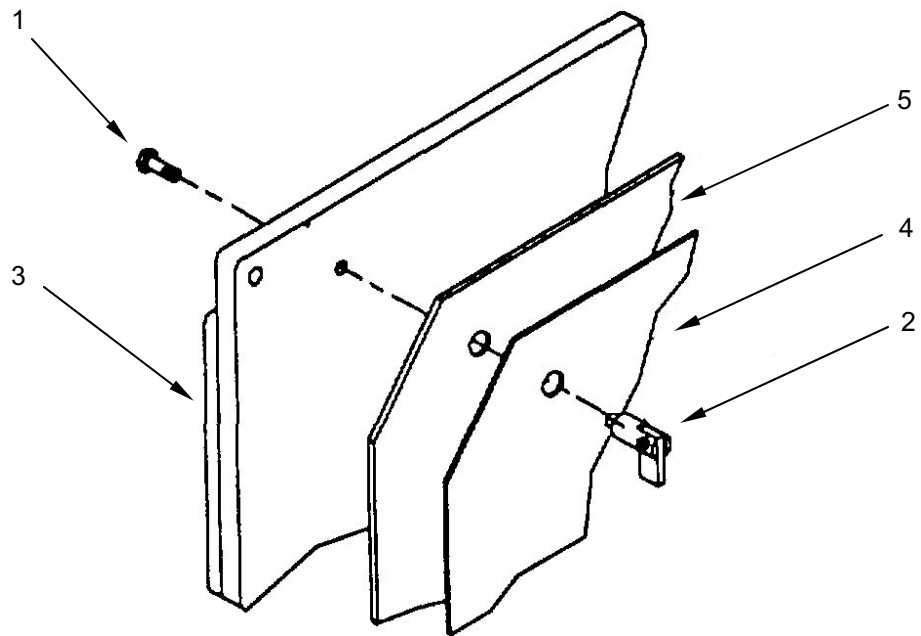

Figure 1. Repair Mapboard Assembly.

END OF TASK

REPLACE**Replace Mapboard**

Replace a mapboard that cannot be repaired using the procedures in this WP, or is otherwise unserviceable. Refer to WP 0005 for installation procedures.

END OF TASK**END OF WORK PACKAGE**

**UNIT MAINTENANCE
MODULAR COMMAND POST SYSTEM (MCPS), SMALL
ILLUSTRATED LIST OF MANUFACTURED ITEMS**

ILLUSTRATED LIST OF MANUFACTURED ITEMS INTRODUCTION

Scope

This work package includes complete instructions for making items authorized to be manufactured or fabricated at the Unit maintenance level.

How to Use the Index of Manufactured Items

A part number index in alphabetical order is provided for cross referencing the part number of the item to be manufactured to the page which covers fabrication criteria.

Explanations of Illustrations of Manufactured Items

All instructions needed by maintenance personnel to manufacture the item are included on the illustrations. (When applicable, a reference to the associated RPSTL TM or RPSTL work package shall be entered here.) All bulk materials needed for manufacture of an item are listed by part number or specification number in a tabular list on the illustration.

INITIAL SETUP**Tools and Special Tools**

Tool Kit, General Mechanic's (WP 0046, Item 7)

Personnel Required

One

Materials/Parts

Staple (WP 0049, Item 14)
Cord, Elastic (WP 0041, Item 4)

Equipment Condition

MCPS struck (WP 0005)

Fabricate Elastic Cords in Frame Assembly

Fabricate replacement elastic cords as follows:

NOTE

If elastic cords are being replaced to environmental damage or have been "worn out", replace all three as a set.

1. Cut a length of cord (**Figure 1, Item 1**) approximately 24 inches in length.
2. Loop one end of the cord (**Figure 1, Item 1**) around the ridge purlin of the tent frame, and draw 3 inches of cord down.
3. Pinch the free end (**Figure 1, Item 2**) of the cord (**Figure 1, Item 1**) together with the standing portion to form a loop, and position a staple (**Figure 1, Item 3**) approximately 1 inch from the end of the cord. Use pliers to crimp the staple down and secure the loop around the purlin.
4. Place an additional staple (**Figure 1, Item 3**) next to the first.
5. Loop the remaining free end of the cord (**Figure 1, Item 1**) around the cable of the tent frame, and draw 3 inches of cord down.
6. Repeat steps 3. and 4.

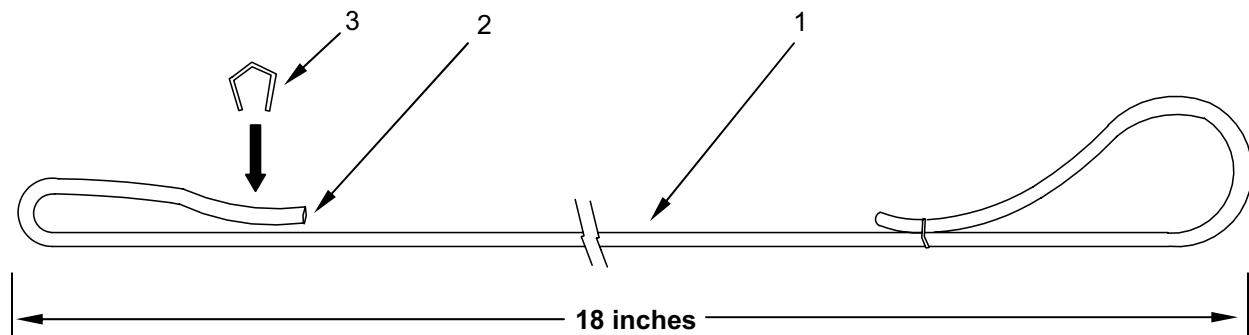

Figure 1. Elastic Cord Fabrication.

END OF TASK

END OF WORK PACKAGE

CHAPTER 8

**DIRECT SUPPORT MAINTENANCE INSTRUCTIONS
FOR
MODULAR COMMAND POST SYSTEM (MCPS), SMALL**

**DIRECT SUPPORT MAINTENANCE
TENT FABRIC ASSEMBLIES
REPAIR**

INITIAL SETUP
Tools and Special Tools

Sewing Machine, Industrial (WP 0046, Item 6)

Personnel Required

One

Materials/Parts

Tentage fabric (WP 0041, Items 1, 2)
Wood dunnage
Thread (WP 0041, Items 24 through 27)

References

FM 10-16

Equipment Condition

MCPS struck (WP 0005) and damaged
section removed.

REPAIR

Repairs by machine stitching are preferred to hand stitched field repairs or adhesive patches. Any rips or tears to fabric over 6 inches in length but under 12 inches must be machine stitched. It is advisable to conduct additional repair with machine stitching at the earliest practical opportunity after field repairs have been made.

NOTE

Replace fabric section with rips or tears exceeding 12 inches in length. Repair is not authorized.

Machine Stitching

All stitch types, except bartacking, shall conform to FED-STD 751. Lock Stitch Type 301 (**Figure 1, Item 1**) and Chain Stitch 401 (**Figure 2, Item 2**) stitching requires 5 to 7 stitches per inch. Bartacking shall be 1/8 inch in width and free of thread breaks and loose stitching.

Thread Breaks. Thread breaks in stitching shall be overstitched not less than 1 inch at each break on stitch type 301 (**Figure 1, Item 1**), and not less than 1 ½ inches at each break on stitch type 401 (**Figure 2, Item 2**). Thread breaks in type 401 may be overstitched with stitch type 301. Thread breaks noted during inspection must be repaired by overstitching the existing stitching starting from a distance of 1 inch beyond the break. The ends of repair stitching are not required to be backstitched.

Stitching Ends. The ends of type 301 (**Figure 1, Item 1**) stitching shall be overstitched not less than 1 inch except where ends, are turned under in a hem or held down by other stitching. Where 301 stitching performed automatically on stitch patterns such as box, box with cross-stitch, "W" stitching or straight line tacking, at least three tying, overlapping, or back stitches shall be used to secure the ends of stitching.

Skipped Stitches. Two or more consecutively skipped stitches occurring in type 301 (**Figure 1, Item 1**) stitching shall be overstitched not less than 1 inch. Any skipped stitches in type 401 (**Figure 2, Item 2**) stitching shall be overstitched not less than 1 ½ inches. Skipped stitches in 401 stitching may be overstitched with type 301 stitching. Skipped stitches noted during inspection shall be repaired as specified for thread breaks above.

Automatic Stitching

Automatic stitching machines may be used to perform any of the required stitch patterns provided the requirements of the stitch pattern, stitches per inch, size and type of thread are met, and at least three or more overlapping, tying or backstitches secure the ends of the stitching.

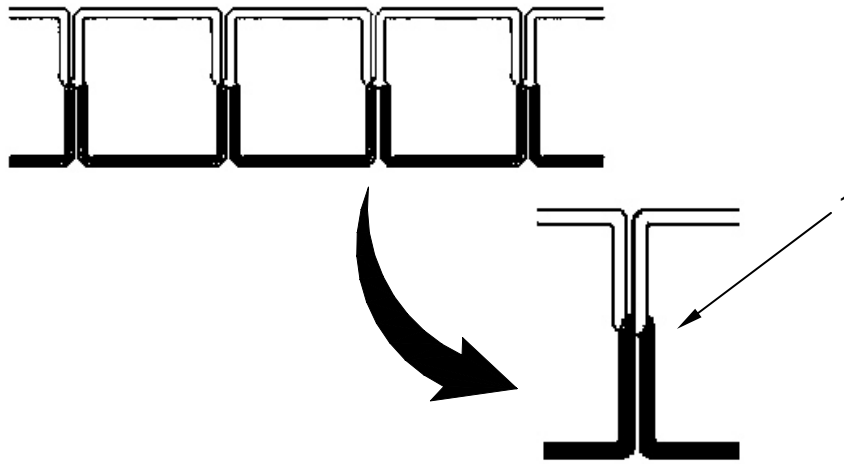

Figure 1. Type 301 Lock Stitch.

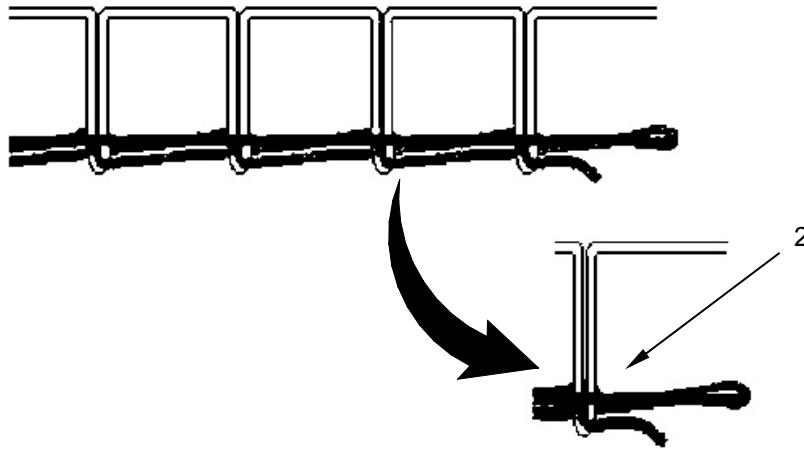

Figure 2. Type 401 Chain Stitch.

END OF TASK

END OF WORK PACKAGE

CHAPTER 9
PARTS INFORMATION
FOR
MODULAR COMMAND POST SYSTEM (MCPS), SMALL

**OPERATOR, UNIT, AND DIRECT SUPPORT MAINTENANCE
MODULAR COMMAND POST SYSTEM (MCPS), SMALL
REPAIR PARTS AND SPECIAL TOOLS LISTS (RPSTL) INTRODUCTION**

INTRODUCTION

SCOPE

This RPSTL lists and authorizes spares and repair parts; special tools; special test, measurement, and diagnostic equipment (TMDE); and other special support equipment required for performance of operator, unit, and direct support maintenance of the Modular Command Post System (MCPS), Small. It authorizes the requisitioning, issue, and disposition of spares, repair parts, and special tools as indicated by the source, maintenance, and recoverability (SMR) codes.

GENERAL

In addition to the Introduction work package, this RPSTL is divided into the following work packages.

1. Repair Parts List Work Packages. Work packages containing lists of spares and repair parts authorized by this RPSTL for use in the performance of maintenance. These work packages also include parts which must be removed for replacement of the authorized parts. Parts lists are composed of functional groups in ascending alphanumeric sequence, with the parts in each group listed in ascending figure and item number sequence. Sending units, brackets, filters, and bolts are listed with the component they mount on. Bulk materials are listed by item name in FIG. BULK at the end of the work packages. Repair parts kits are listed at the end of the individual work packages. Repair parts for reparable special tools are also listed in a separate work package. Items listed are shown on the associated illustrations.

2. Special Tools List Work Packages. Work packages containing lists of special tools, special TMDE, and special support equipment authorized by this RPSTL (as indicated by Basis of Issue (BOI) information in the DESCRIPTION AND USABLE ON CODE (UOC) column). Tools that are components of common tool sets and/or Class VII are not listed.

3. Cross-Reference Indexes Work Packages. There are two crossreference indexes work packages in this RPSTL: the National Stock Number (NSN) Index work package, and the Part Number (P/N) Index work package. The National Stock Number Index work package refers you to the figure and item number. The Part Number Index work package refers you to the figure and item number.

EXPLANATION OF COLUMNS IN THE REPAIR PARTS LIST AND SPECIAL TOOLS LIST WORK PACKAGES

ITEM NO. (Column (1)). Indicates the number used to identify items called out in the illustration.

SMR CODE (Column (2)). The SMR code containing supply/requisitioning information, maintenance level authorization criteria, and disposition instruction, as shown in the following breakout:

Table 1. SMR Code Explanation.

<u>Source</u>		<u>Maintenance</u>	
<u>Code</u>		<u>Code</u>	
<u>XX</u>		<u>XX</u>	
1st two positions: how to get an item.	3rd position: who can install, replace, or use the item.	4th position: Who can do complete repair* on the item	5th position: Who determines disposition action on unserviceable items.

*Complete Repair: Maintenance capacity, capability, and authority to perform all corrective maintenance tasks of the "Repair" function in a use/user environment in order to restore serviceability to a failed item.

Source Code. The source code tells you how you get an item needed for maintenance, repair, or overhaul of an end item/equipment. Explanations of source codes follow:

<u>Source Code</u>	<u>Application/Explanation</u>
PA	
PB	
PC	NOTE
PD	Items coded PC are subject to deterioration.
PE	
PF	
PG	Stock items; use the applicable NSN to requisition/request items with these source codes. They are authorized to the level indicated by the code entered in the 3rd position of the SMR code.
PH	
PR	
PZ	
KD	
KF	
KB	Items with these codes are not to be requested/requisitioned individually. They are part of a kit which is authorized to the maintenance level indicated in the 3rd position of the SMR code. The complete kit must be requisitioned and applied.
MO-Made at unit/AVUM level	
MF-Made at DS/AVIM level	
MH-Made at GS level	
ML-Made at SRA	
MD-Made at depot	
MG-Navy only	Items with these codes are not to be requisitioned/requested individually. They must be made from bulk material which is identified by the part number in the DESCRIPTION AND USABLE ON CODE (UOC) column and listed in the bulk material group work package of the RPSTL. If the item is authorized to you by the 3rd position code of the SMR code, but the source code indicates it is made at higher level, order the item from the higher level of maintenance.
AO-Assembled by unit/AVUM level	
AF-Assembled by DS/AVIM level	
AH-Assembled by GS level	
AL-Assembled by SRA	
AD-Assembled by depot	
AG-Navy only	Items with these codes are not to be requested/requisitioned individually. The parts that make up the assembled item must be requisitioned or fabricated and assembled at the level of maintenance indicated by the source code. If the 3rd position of the SMR code authorizes you to replace the item, but the source code indicates the item is assembled at a higher level, order the item from the higher level of maintenance.
XA	Do not requisition an "XA" coded item. Order the next higher assembly.(Refer to NOTE below.)
XB	If an item is not available from salvage, order it using the CAGEC and part number.
XC	Installation drawings, diagrams, instruction sheets, field service drawings; identified by manufacturer's part number.
XD	Item is not stocked. Order an XD-coded item through normal supply channels using the CAGEC and part number given, if no NSN is available.

NOTE

Cannibalization or controlled exchange, when authorized, may be used as a source of supply for items with the above source codes except for those items source coded "XA" or those aircraft support items restricted by requirements of AR 750-1.

Maintenance Code. Maintenance codes tell you the level(s) of maintenance authorized to use and repair support items. The maintenance codes are entered in the third and fourth positions of the SMR code as follows:

Third Position. The maintenance code entered in the third position tells you the lowest maintenance level authorized to remove, replace, and use an item. The maintenance code entered in the third position will indicate authorization to the following levels of maintenance:

Maintenance Code

Application/Explanation

O* -	Unit level/AVUM maintenance can remove, replace, and use the item.
F -	Direct support/AVIM maintenance can remove, replace, and use the item.
H -	General support maintenance can remove, replace, and use the item.
L -	Specialized repair activity can remove, replace, and use the item.
G -	Afloat and ashore intermediate maintenance can remove, replace, and use the item (Navy only).
K -	Contractor facility can remove, replace, and use the item.
Z -	Item is not authorized to be removed, replace, or used at any maintenance level.
D -	Depot can remove, replace, and use the item.

*NOTE - Army may use C in the third position. However, for joint service publications, Army will use O.

Fourth Position. The maintenance code entered in the fourth position tells you whether or not the item is to be repaired and identifies the lowest maintenance level with the capability to do complete repair (perform all authorized repair functions).

NOTE

Some limited repair may be done on the item at a lower level of maintenance, if authorized by the Maintenance Allocation Chart (MAC) and SMR codes.

Maintenance Code

Application/Explanation

O -	Unit/AVUM is the lowest level that can do complete repair of the item.
F -	Direct support/AVIM is the lowest level that can do complete repair of the item.
H -	General support is the lowest level that can do complete repair of the item.
L -	Specialized repair activity (enter specialized repair activity designator) is the lowest level that can do complete repair of the item.
D -	Depot is the lowest level that can do complete repair of the item.
G -	Both afloat and ashore intermediate levels are capable of complete repair of item. (Navy only)
K -	Complete repair is done at contractor facility.
Z -	Nonreparable. No repair is authorized.
B -	No repair is authorized. No parts or special tools are authorized for maintenance of "B" coded item. However, the item may be reconditioned by adjusting, lubricating, etc., at the user level.

Recoverability Code. Recoverability codes are assigned to items to indicate the disposition action on unserviceable items. The recoverability code is shown in the fifth position of the SMR code as follows:

Recoverability

<u>Recoverability Code</u>	<u>Application/Explanation</u>
Z -	Nonreparable item. When unserviceable, condemn and dispose of the item at the level of maintenance shown in the third position of the SMR code.
O -	Reparable item. When uneconomically repairable, condemn and dispose of the item at the unit level.
F -	Reparable item. When uneconomically repairable, condemn and dispose of the item at the direct support level.
H -	Reparable item. When uneconomically repairable, condemn and dispose of the item at the general support level.
D -	Reparable item. When beyond lower level repair capability, return to depot. Condemnation and disposal of item are not authorized below depot level.
L -	Reparable item. Condemnation and disposal not authorized below Specialized Repair Activity (SRA).
A -	Item requires special handling or condemnation procedures because of specific reasons (such as precious metal content, high dollar value, critical material, or hazardous material). Refer to appropriate manuals/directives for specific instructions.
G -	Filed level reparable item. Condemn and dispose at either afloat or ashore intermediate levels. (Navy only)
K -	Reparable item. Condemnation and disposal to be performed at contractor facility

NSN (Column (3)). The NSN for the item is listed in this column.

CAGEC (Column (4)). The Commercial and Government Entity Code (CAGEC) is a five-digit code which is used to identify the manufacturer, distributor, or Government agency/activity that supplies the item.

PART NUMBER (Column (5)). Indicates the primary number used by the manufacturer (individual, company, firm, corporation, or Government activity), which controls the design and characteristics of the item by means of its engineering drawings, specifications, standards, and inspection requirements to identify an item or range of items.

NOTE

When you use an NSN to requisition an item, the item you receive may have a different part number from the number listed.

DESCRIPTION AND USABLE ON CODE (UOC) (Column (6)). This column includes the following information:

1. The federal item name, and when required, a minimum description to identify the item.
2. Part numbers of bulk materials are referenced in this column in the line entry to be manufactured or fabricated.
3. Hardness Critical Item (HCI). A support item that provides the equipment with special protection from electromagnetic pulse (EMP) damage during a nuclear attack.
4. The statement END OF FIGURE appears just below the last item description in column (6) for a given figure in both the repair parts list and special tools list work packages.

QTY (Column (7)). The QTY (quantity per figure) column indicates the quantity of the item used in the breakout shown on the illustration/figure, which is prepared for a functional group, subfunctional group, or an assembly. A "V" appearing in this column instead of a quantity indicates that the quantity is variable and quantity may change from application to application.

EXPLANATION OF CROSS-REFERENCE INDEXES WORK PACKAGES FORMAT AND COLUMNS

1. National Stock Number (NSN) Index Work Package. NSNs in this index are listed in National Item Identification Number (NIIN) sequence.

STOCK NUMBER Column. This column lists the NSN in NIIN sequence. The NIIN consists of the last nine digits of the NSN. When using this column to locate an item, ignore the first four digits of the NSN. However, the complete NSN should be used when ordering items by stock number. For example, if the NSN is 5385-01-574-1476, the NIIN is 01-574-1476.

FIG. Column. This column lists the number of the figure where the item is identified/located. The figures are in numerical order in the repair parts list and special tools list work packages.

ITEM Column. The item number identifies the item associated with the figure listed in the adjacent FIG. column. This item is also identified by the NSN listed on the same line.

2. Part Number (P/N) Index Work Package. Part numbers in this index are listed in ascending alphanumeric sequence (vertical arrangement of letter and number combinations which places the first letter or digit of each group in order A through Z, followed by the numbers 0 through 9 and each following letter or digit in like order).

PART NUMBER Column. Indicates the part number assigned to the item.

FIG. Column. This column lists the number of the figure where the item is identified/located in the repair parts list and special tools list work packages.

ITEM Column. The item number is the number assigned to the item as it appears in the figure referenced in the adjacent figure number column.

SPECIAL INFORMATION

UOC. The UOC appears in the lower left corner of the Description Column heading. Usable on codes are shown as "UOC:..." in the Description Column (justified left) on the first line under the applicable item/nomenclature. Uncoded items are applicable to all models. Identification of the UOCs used in the RPSTL are:

Code	Used On
EWG	MCPS Type I (legacy system, green)
EZN	MCPS Type I (legacy system, tan)
FUD	MCPS Type III (green)
FUE	MCPS Type III (tan)

Fabrication Instructions. Bulk materials required to manufacture items are listed in the bulk material functional group of this RPSTL. Part numbers for bulk material are also referenced in the Description Column of the line item entry for the item to be manufactured/fabricated. Detailed fabrication instructions for items source coded to be manufactured or fabricated are found in TM 10-8340-243-13&P.

Index Numbers. Items which have the word BULK in the figure column will have an index number shown in the item number column. This index number is a cross-reference between the NSN / Part Number (P/N) Index work packages and the bulk material list in the repair parts list work package.

Illustrations List. The illustrations in this RPSTL contain unit authorized items. Illustrations published in (enter applicable TM number for the higher maintenance level RPSTL, e.g., for direct support, general support, etc.) that contain unit authorized items also appear in this RPSTL. The tabular list in the repair parts list work package contains only those parts coded "O" in the third position of the SMR code, therefore, there may be a break in the item number sequence.

HOW TO LOCATE REPAIR PARTS

1. When NSNs or Part Numbers Are Not Known.

First. Using the table of contents, determine the assembly group to which the item belongs. This is necessary since figures are prepared for assembly groups and subassembly groups, and lists are divided into the same groups.

Second. Find the figure covering the functional group or the subfunctional group to which the item belongs.

Third. Identify the item on the figure and note the number(s).

Fourth. Look in the repair parts list work packages for the figure and item numbers. The NSNs and part numbers are on the same line as the associated item numbers.

2. When NSN Is Known.

First. If you have the NSN, look in the STOCK NUMBER column of the NSN index work package. The NSN is arranged in NIIN sequence. Note the figure and item number next to the NSN.

Second. Turn to the figure and locate the item number. Verify that the item is the one you are looking for.

3. When Part Number Is Known.

First. If you have the part number and not the NSN, look in the PART NUMBER column of the part number index work package. Identify the figure and item number.

Second. Look up the item on the figure in the applicable repair parts list work package.

END OF WORK PACKAGE

**OPERATOR, UNIT, AND DIRECT SUPPORT MAINTENANCE
MODULAR COMMAND POST SYSTEM (MCPS), SMALL**

NSN 8340-01-323-2454

NSN 8340-01-334-7529

NSN 8340-01-528-4188

NSN 8340-01-528-8210

FRAME ASSEMBLY

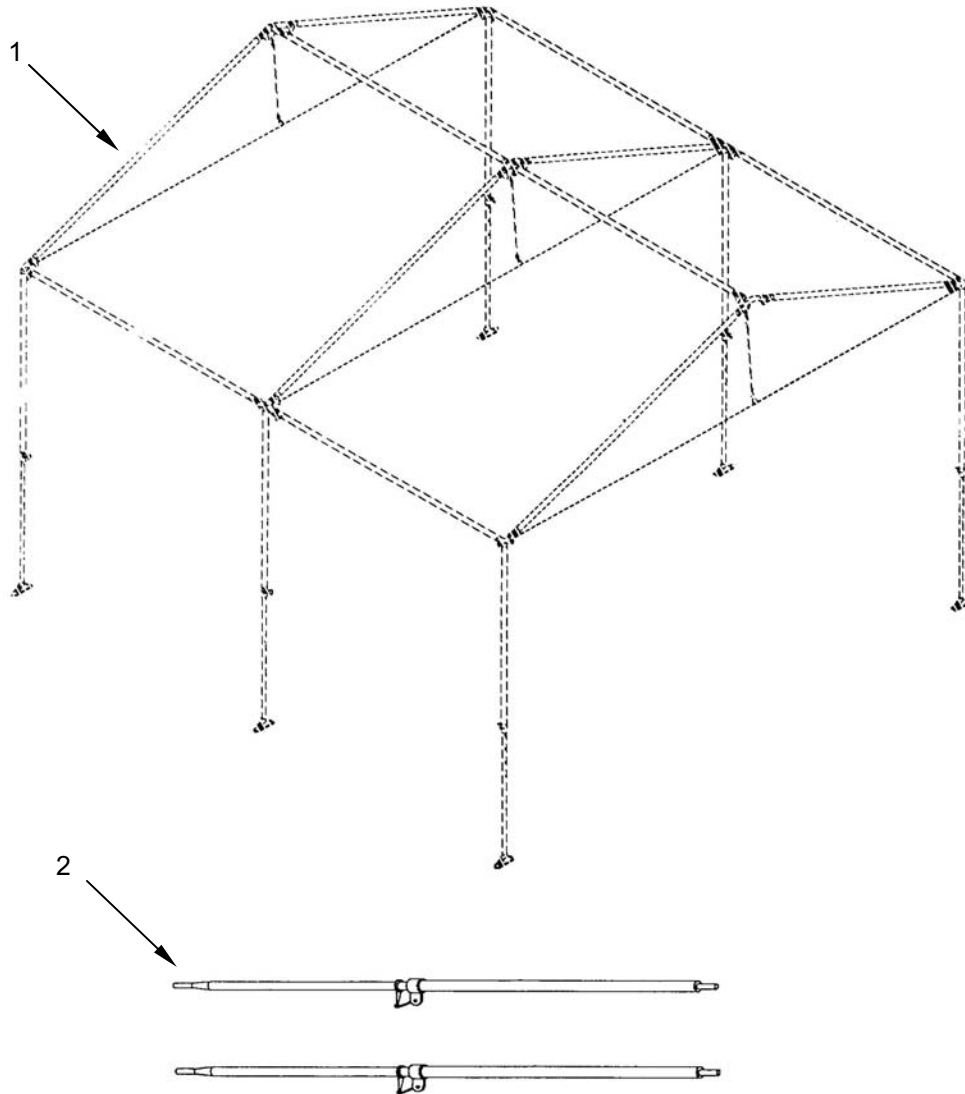

**Figure 1. Frame Assembly.
Sheet 1 of 3**

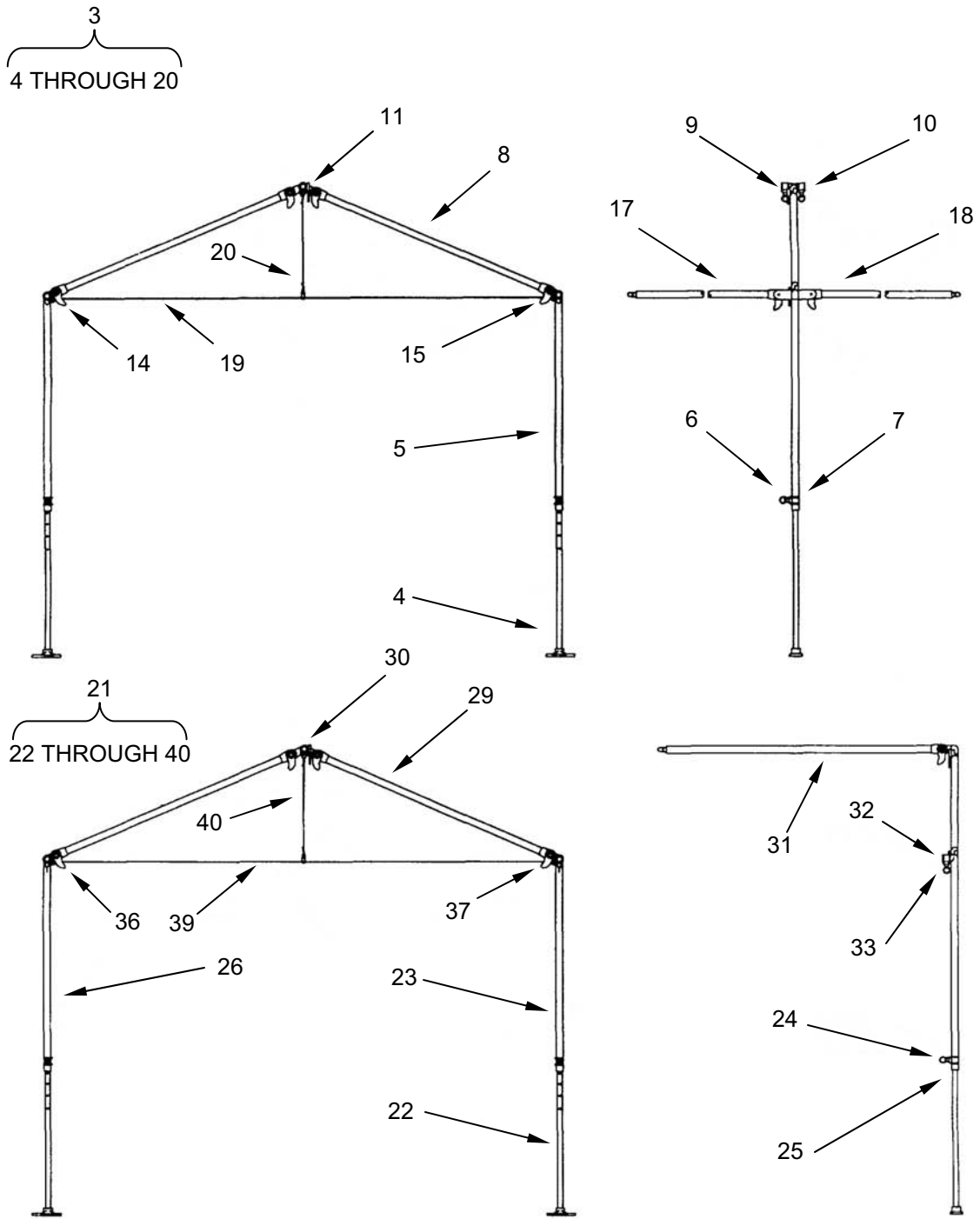

Figure 1. Frame Assembly.
Sheet 2 of 3

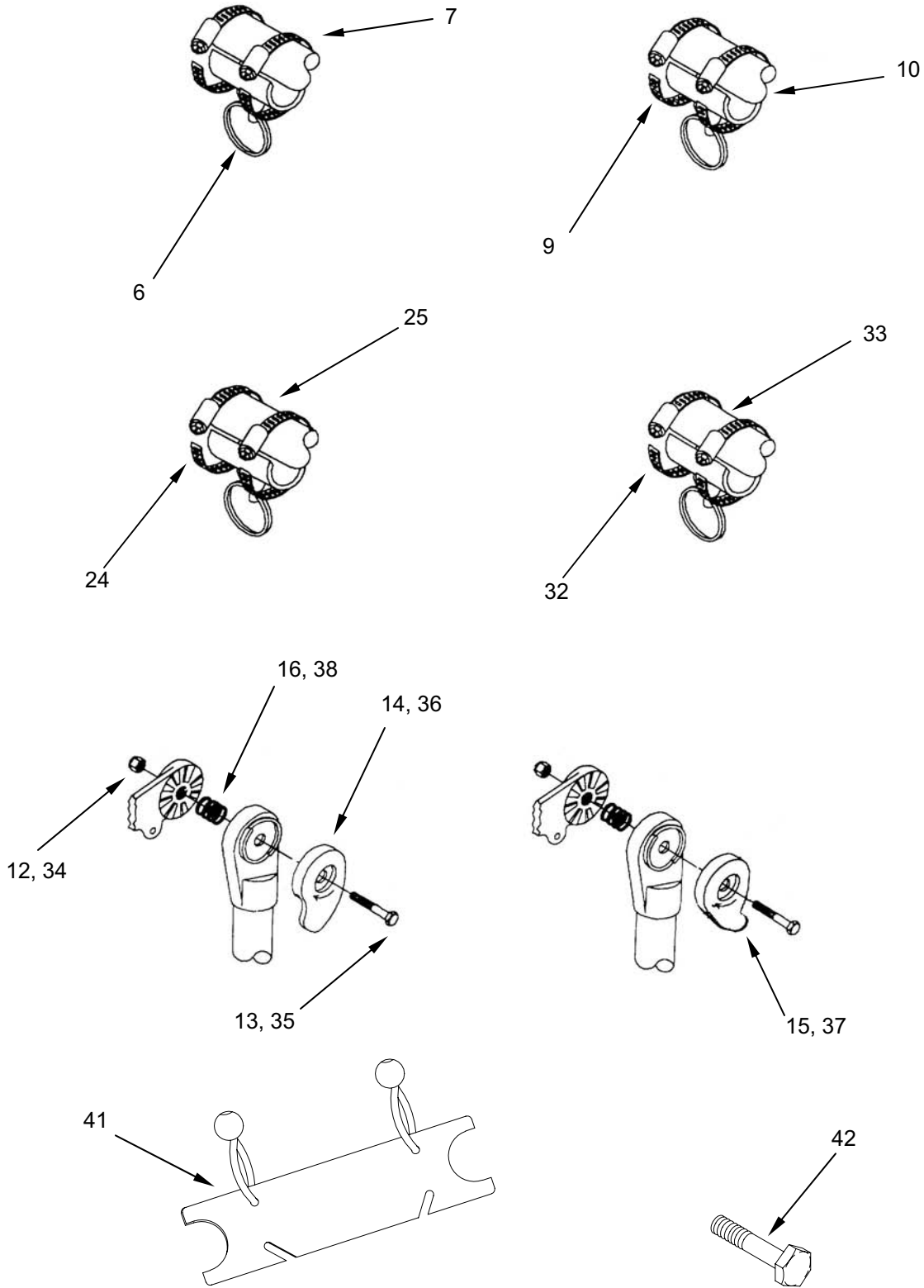

Figure 1. Frame Assembly.
Sheet 3 of 3

(1) ITEM NO.	(2) SMR CODE	(3) NSN	(4) CAGEC	(5) PART NUMBER	(6) DESCRIPTION AND USABLE ON CODE (UOC)	(7) QTY
GROUP 01 FRAME ASSEMBLY						
FIG. 1 FRAME ASSEMBLY						
1	PAOOO	8340-01-334-2341	81337	5-4-6947	FRAME ASSEMBLY	1
2	PAOZZ	8340-01-333-4126	81337	5-4-6980	..POLE, TENT	2
3	PAOOO	5410-01-331-0155	81337	5-4-6967	..FRAME ASSEMBLY, CENTER ...	1
4	PAOOO	5410-01-333-5918	81337	5-4-6948	..LEG ASSEMBLY, TUBULAR.....	2
5	PAOOO	5410-01-332-7684	81337	5-4-6968	..LEG ASSEMBLY, TUBULAR.....	2
6	PAOZZ	5340-01-333-4114	81337	5-4-6957	...PIN, QUICK RELEASE	1
7	XDOZZ	3020-01-333-9193	36708	350-020-102	...CLAMP, WORM GEAR.....	2
8	PAOOO	5410-01-333-4719	81337	5-4-6950	..CONNECTOR, RAFTER, FRAME	2
9	XDOZZ	3020-01-333-9193	36708	350-020-102	..CLAMP, WORM GEAR.....	4
10	PAOZZ	5340-01-333-4114	81337	5-4-6957	..PIN, QUICK RELEASE	2
11	PAOZZ	5410-01-331-3285	81337	5-4-6944	..JOINT, PEAK, CENTER.....	1
12	PAOZZ	5310-00-914-6028	81349	M45913/1- 6CS3	..NUT, SELF-LOCKING, HEXAGON, 3/8 - 16.....	8
13	PAOZZ	5305-01-423-5369	96906	MS35307-367	..SCREW, CAP, HEXAGON HEAD, 3/8 - 16 X 2.25.....	8
14	PAOZZ	5340-01-327-9355	81337	5-4-6954	..HANDLE, DOOR, RIGHT HAND.....	4
15	PAOZZ	5340-01-333-8474	81337	5-4-6955	..HANDLE, DOOR, LEFT HAND...	4
16	PAOZZ	5360-01-250-6959	70472	C-0720-055- 0620S	..SPRING, HELICAL, COMPRESSION.....	4
17	PAOZZ	5410-01-331-7325	81337	5-4-6976	..CONNECTOR, FRAME	2
18	PAOOZ	5410-01-331-3288	81337	5-4-6956	..CONNECTOR, FRAME	2
19	PAOZZ	6150-01-331-2374	81337	5-4-6960	..CABLE ASSEMBLY.....	1
20	MOOZZ		81337	5-4-6967-17	..CORD, ELASTIC, 18 IN LG, MAKE FROM 81349/MIL-C-5651 .	1
21	PAOOO	5410-01-331-3289	81337	5-4-6946	..FRAME ASSEMBLY, END	2
22	PAOOO	5410-01-333-5918	81337	5-4-6948	..LEG ASSEMBLY, TUBULAR.....	2
23	PAOOO	5410-01-332-7685	81337	5-4-6965	..LEG ASSEMBLY, TUBULAR	1
24	XDOZZ	3020-01-333-9193	36708	350-020-102	...CLAMP, WORM GEAR.....	2
25	PAOZZ	5340-01-333-4114	81337	5-4-6957	...PIN, QUICK RELEASE	1
26	PAOZZ	5410-01-332-7686	81337	5-4-6966	..LEG ASSEMBLY, TUBULAR.....	1
27	XDOZZ	3020-01-333-9193	36708	350-020-102	...CLAMP, WORM GEAR.....	2
28	PAOZZ	5340-01-333-4114	81337	5-4-6957	...PIN, QUICK RELEASE	1
29	PAOZZ	5410-01-333-4719	81337	5-4-6950	..CONNECTOR, RAFTER, FRAME	2
30	PAOZZ	3040-01-328-8016	81337	5-4-6953	..END FITTING, FLEXIBLE CASING	1
31	PAOOO	5410-01-331-3288	81337	5-4-6956	..CONNECTOR, FRAME	1
32	XDOZZ	3020-01-333-9193	36708	350-020-102	..CLAMP, WORM GEAR.....	4
33	PAOZZ	5340-01-333-4114	81337	5-4-6957	..PIN, QUICK RELEASE	2
34	PAOZZ	5310-00-914-6028	81349	M45913/1- 6CS3	..NUT, SELF-LOCKING, HEXAGON, 3/8-16.....	5
35	PAOZZ	5305-01-423--5369	96906	MS35307-367	..SCREW, CAP, HEXAGON HEAD, 3/8-16 X 2.25	5
36	PAOZZ	5340-01-327-9355	81337	5-4-6954	..HANDLE, DOOR, RIGHT HAND.....	4
37	PAOZZ	5340-01-333-8474	81337	5-4-6955	..HANDLE, DOOR, LEFT HAND...	4

(1) ITEM NO.	(2) SMR CODE	(3) NSN	(4) CAGEC	(5) PART NUMBER	(6) DESCRIPTION AND USABLE ON CODE (UOC)	(7) QTY
GROUP 01 FRAME ASSEMBLY						
FIG. 1 FRAME ASSEMBLY						
38	PAOZZ	5360-01-250-6959	70472	C-0720-055-0620S	..SPRING, HELICAL, COMPRESSION.....	8
39	PAOZZ	6150-01-331-2374	81337	5-4-6960	..CABLE ASSEMBLY.....	1
40	MOOZZ		81337	5-4-6967-17	..CORD, ELASTIC, 18 IN LG, MAKE FROM 81349/ MIL-C- 5651.....	1
41	PAOZZ	8340-01-524-8052	81337	5-4-9686-1	BRACKET, TENT FRAME UOC: FUD, FUE	6
42	PAOZZ	5306-01-475-9900	53711	6931056	BOLT, MACHINE, 1/4-20 X 1.5 IN.....	4
END OF FIGURE						

**OPERATOR, UNIT, AND DIRECT SUPPORT MAINTENANCE
MODULAR COMMAND POST SYSTEM (MCPS), SMALL**

NSN 8340-01-323-2454

NSN 8340-01-334-7529

NSN 8340-01-528-4188

NSN 8340-01-528-8210

PLAIN WALL ASSEMBLY

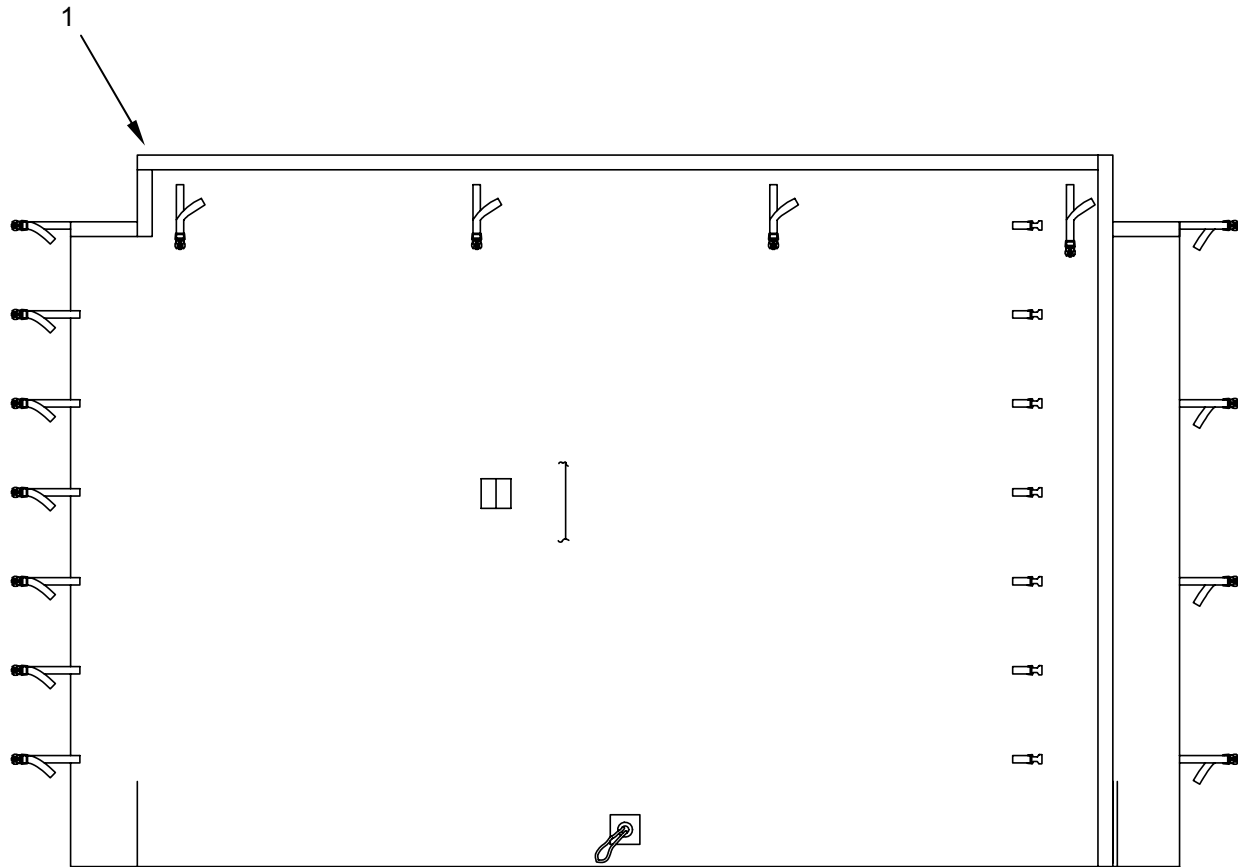

Figure 2. Plain Wall Assembly.

(1) ITEM NO.	(2) SMR CODE	(3) NSN	(4) CAGEC	(5) PART NUMBER	(6) DESCRIPTION AND USABLE ON CODE (UOC)	(7) QTY
					GROUP 0201 PLAIN WALL ASSEMBLY	
					FIG. 2 PLAIN WALL ASSEMBLY	
1	PAOFF	8340-01-333-4718	81337	5-4-6344-1	PLAIN WALL ASSEMBLY, CAMOUFLAGE GREEN UOC: EWG, FUD.....	1
1	PAOFF	8340-01-337-5297	81337	5-4-6344-2	PLAIN WALL ASSEMBLY, DESERT TAN UOC: EZN, FUE	1
END OF FIGURE						

**OPERATOR, UNIT, AND DIRECT SUPPORT MAINTENANCE
MODULAR COMMAND POST SYSTEM (MCPS), SMALL**

NSN 8340-01-323-2454

NSN 8340-01-334-7529

NSN 8340-01-528-4188

NSN 8340-01-528-8210

WINDOW WALL ASSEMBLY

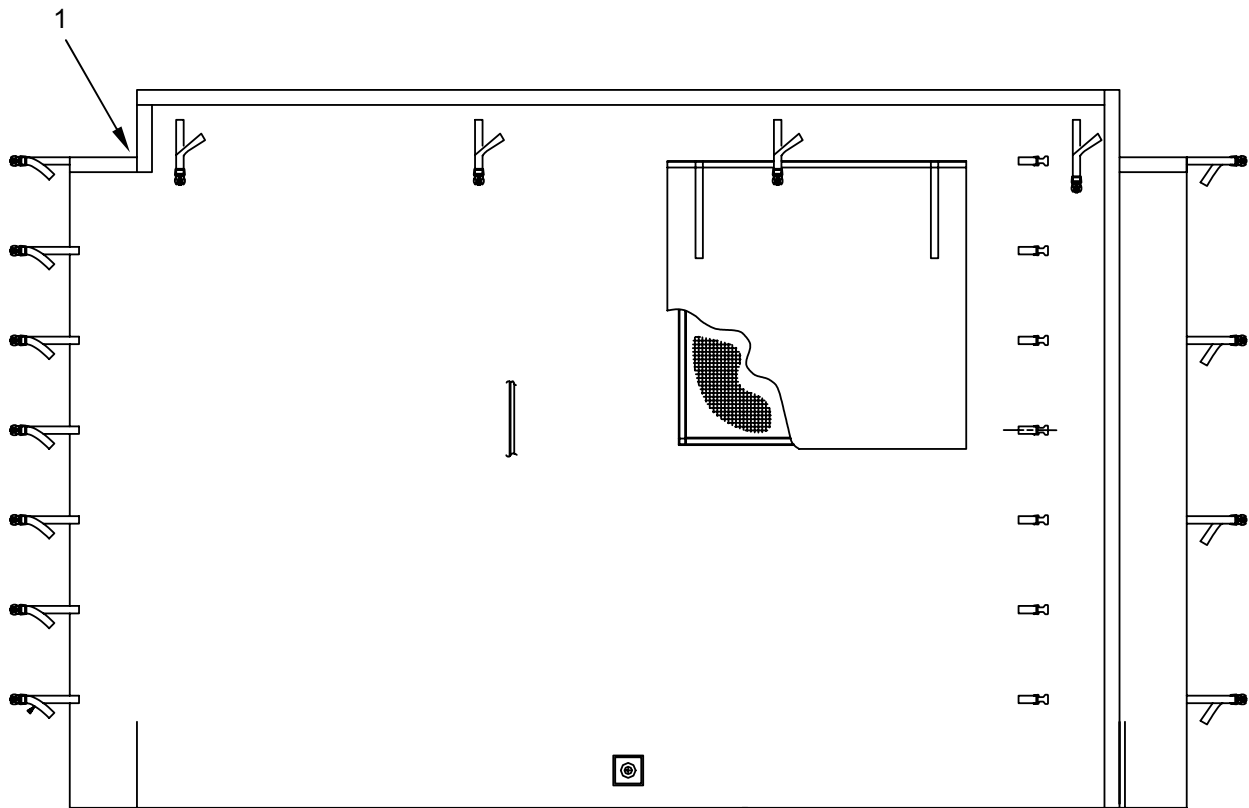

Figure 3. Window Wall Assembly.

(1) ITEM NO.	(2) SMR CODE	(3) NSN	(4) CAGEC	(5) PART NUMBER	(6) DESCRIPTION AND USABLE ON CODE (UOC)	(7) QTY
					GROUP 0202 WINDOW WALL ASSEMBLY	
					FIG. 3 WINDOW WALL ASSEMBLY	
1	PAOFF	8340-01-331-0152	81337	5-4-6345-1	WINDOW WALL ASSEMBLY, CAMOUFLAGE GREEN UOC: EWG	1
1	PAOFF	8340-01-337-5298	81337	5-4-6345-2	WINDOW WALL ASSEMBLY, DESERT TAN UOC: EZN	1
END OF FIGURE						

**OPERATOR, UNIT, AND DIRECT SUPPORT MAINTENANCE
MODULAR COMMAND POST SYSTEM (MCPS), SMALL
NSN 8340-01-323-2454
NSN 8340-01-334-7529
NSN 8340-01-528-4188
NSN 8340-01-528-8210**

HORIZONTAL ECU/WINDOW WALL ASSEMBLY

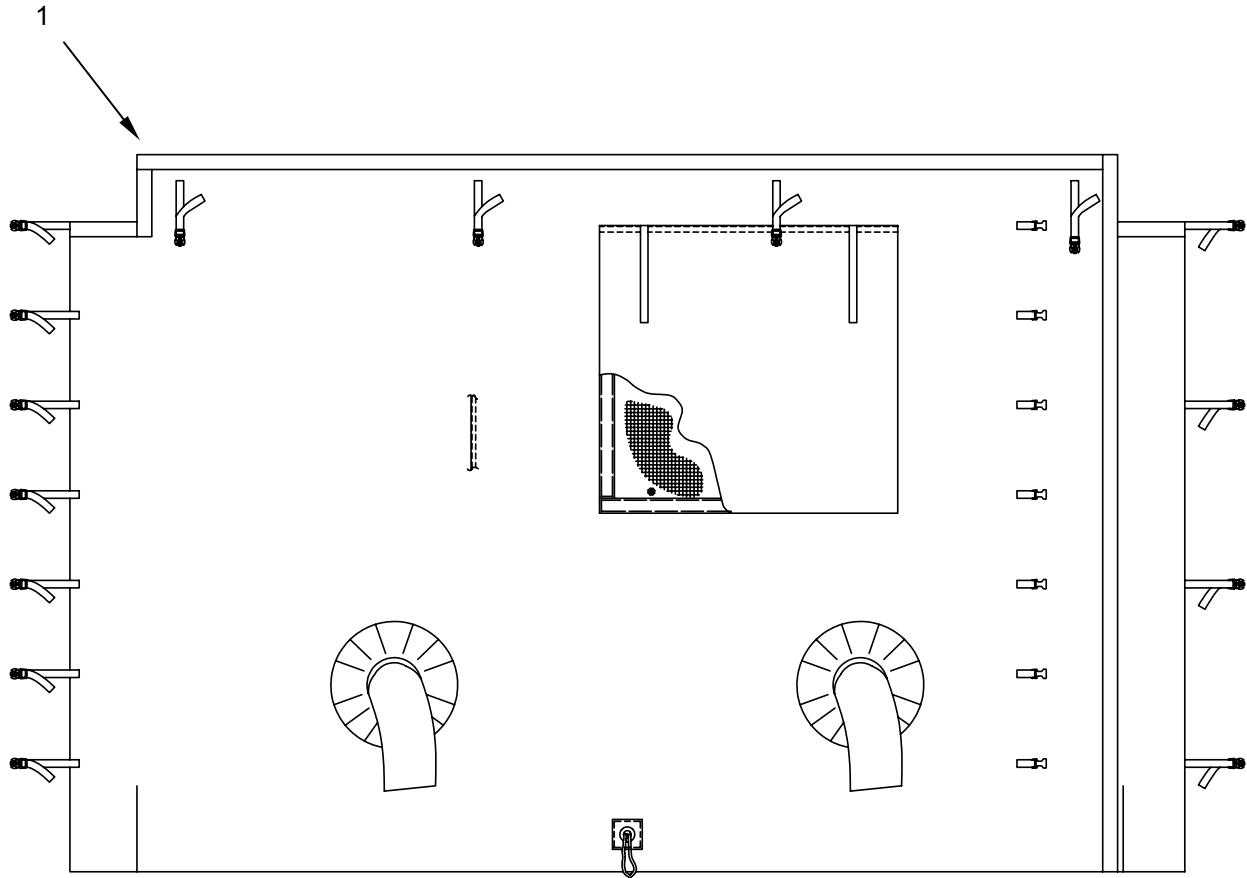

Figure 4. Horizontal ECU/Window Wall Assembly.

(1) ITEM NO.	(2) SMR CODE	(3) NSN	(4) CAGEC	(5) PART NUMBER	(6) DESCRIPTION AND USABLE ON CODE (UOC)	(7) QTY
					GROUP 0203 HORIZONTAL ECU/WINDOW WALL ASSEMBLY	
					FIG. 4 HORIZONTAL ECU/WINDOW WALL ASSEMBLY	
1	PAOFF	8340-01-529-0590	81337	5-4-9691-1	WALL ASSEMBLY, ECU/WINDOW WALL , CAMOUFLAGE GREEN UOC: FUD	1
1	PAOFF	8340-01-529-0596	81337	5-4-9691-2	WALL ASSEMBLY, ECU/WINDOW WALL , DESERT TAN UOC: FUE	1
END OF FIGURE						

OPERATOR, UNIT, AND DIRECT SUPPORT MAINTENANCE
MODULAR COMMAND POST SYSTEM (MCPS), SMALL

NSN 8340-01-323-2454

NSN 8340-01-334-7529

NSN 8340-01-528-4188

NSN 8340-01-528-8210

ENTRANCE WAY ASSEMBLY

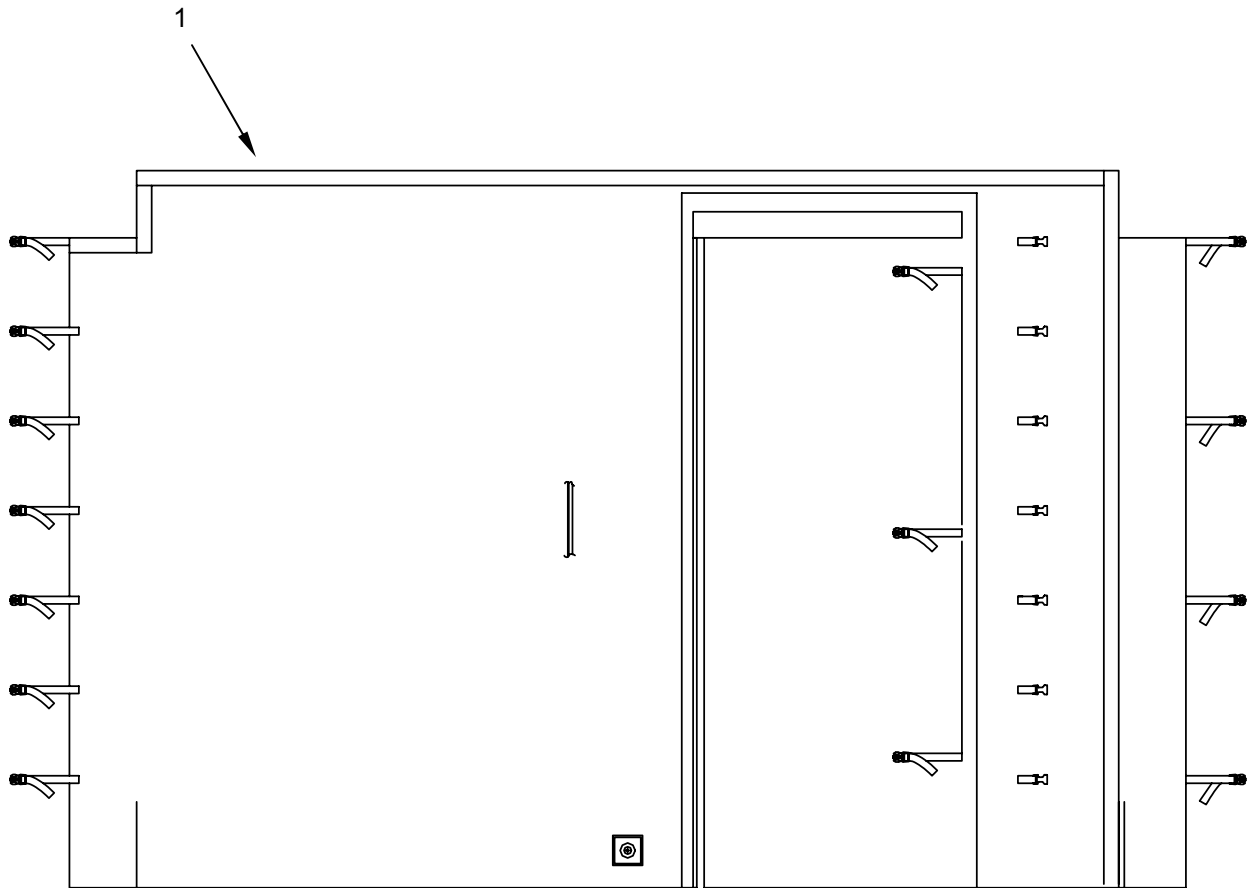

Figure 5. Entrance Way Assembly.

(1) ITEM NO.	(2) SMR CODE	(3) NSN	(4) CAGEC	(5) PART NUMBER	(6) DESCRIPTION AND USABLE ON CODE (UOC)	(7) QTY
					GROUP 0204 ENTRANCE WAY ASSEMBLY	
					FIG. 5 ENTRANCE WAY ASSEMBLY	
1	PAOFF	8340-01-331-3302	81337	5-4-6347-1	ENTRANCE, SHELTER, CAMOUFLAGE GREEN UOC: EWG, FUD.....	1
1	PAOFF	8340-01-337-5299	81337	5-4-6347-2	ENTRANCE, SHELTER, DESERT TAN UOC: EZN, FUE	1
END OF FIGURE						

OPERATOR, UNIT, AND DIRECT SUPPORT MAINTENANCE
MODULAR COMMAND POST SYSTEM (MCPS), SMALL

NSN 8340-01-323-2454

NSN 8340-01-334-7529

NSN 8340-01-528-4188

NSN 8340-01-528-8210

ROOF CAP ASSEMBLY

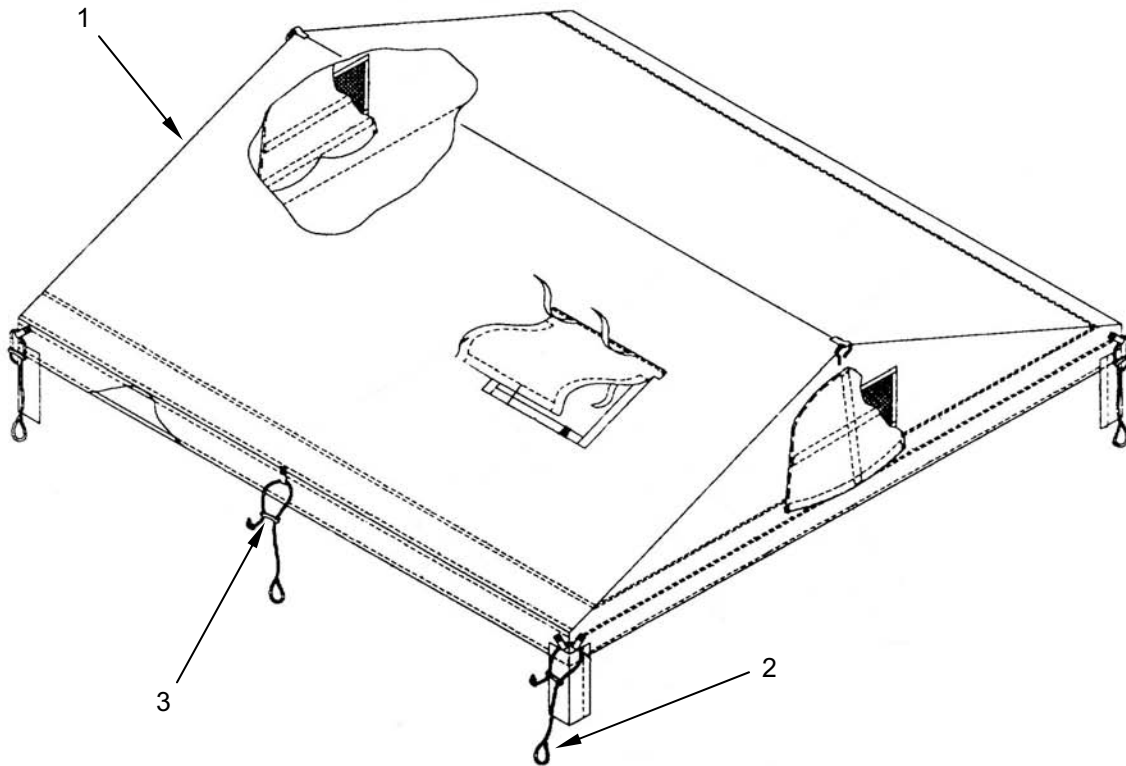

Figure 6. Roof Cap Assembly.

(1) ITEM NO.	(2) SMR CODE	(3) NSN	(4) CAGEC	(5) PART NUMBER	(6) DESCRIPTION AND USABLE ON CODE (UOC)	(7) QTY
					GROUP 0205 ROOF CAP ASSEMBLY	
					FIG. 6 ROOF CAP ASSEMBLY	
1	PAOZZ	8340-01-331-5422	81337	5-4-7478-1	ROOF CAP ASSEMBLY, CAMOUFLAGE GREEN UOC: EWG, FUD.....	1
1	PAOZZ	8340-01-337-5300	81337	5-4-7478-2	ROOF CAP ASSEMBLY, DESERT TAN UOC: EZN, FUE	1
2	MOOZZ		81337	5-4-7478-1-16	.TENT LINE, CLASS A, F MAKE FROM LINE, P/N MIL-L- 1709, TYPE XXVIII, CLASS A, CUT 19 FT LONG.....	8
3	PAOZZ	8340-00-205-2759	70167	23B28045-1	.SLIP, TENT LINE	8
END OF FIGURE						

OPERATOR, UNIT, AND DIRECT SUPPORT MAINTENANCE
MODULAR COMMAND POST SYSTEM (MCPS), SMALL
NSN 8340-01-323-2454
NSN 8340-01-334-7529
NSN 8340-01-528-4188
NSN 8340-01-528-8210

RAIN GUTTER ASSEMBLY

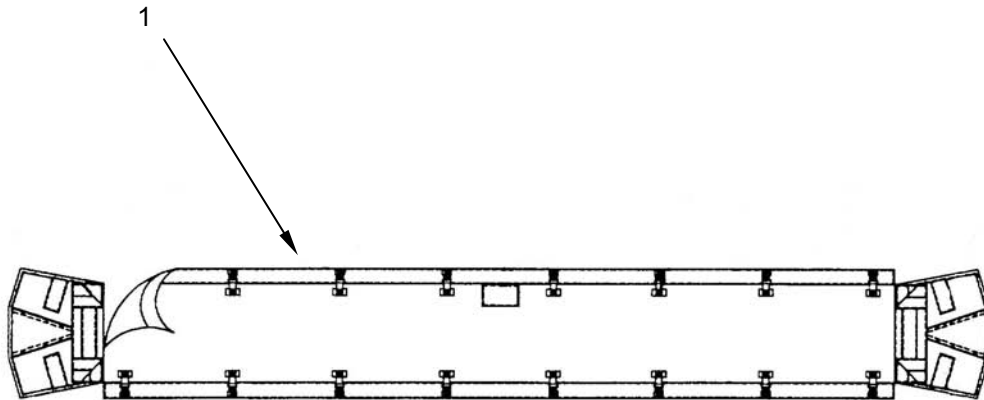

Figure 7. Rain Gutter Assembly.

(1) ITEM NO.	(2) SMR CODE	(3) NSN	(4) CAGEC	(5) PART NUMBER	(6) DESCRIPTION AND USABLE ON CODE (UOC)	(7) QTY
					GROUP 0206 RAIN GUTTER ASSEMBLY	
					FIG. 7 RAIN GUTTER ASSEMBLY	
1	PAOFF	8340-01-331-0153	81337	5-4-6356-1	GUTTER, RAIN, CAMOUFLAGE GREEN UOC: EWG, FUD.....	1
1	PAOFF	8340-01-337-5699	81337	5-4-6356-2	GUTTER, RAIN, DESERT TAN UOC: EZN, FUE	1
END OF FIGURE						

**OPERATOR, UNIT, AND DIRECT SUPPORT MAINTENANCE
MODULAR COMMAND POST SYSTEM (MCPS), SMALL**

NSN 8340-01-323-2454

NSN 8340-01-334-7529

NSN 8340-01-528-4188

NSN 8340-01-528-8210

FLOOR ASSEMBLY

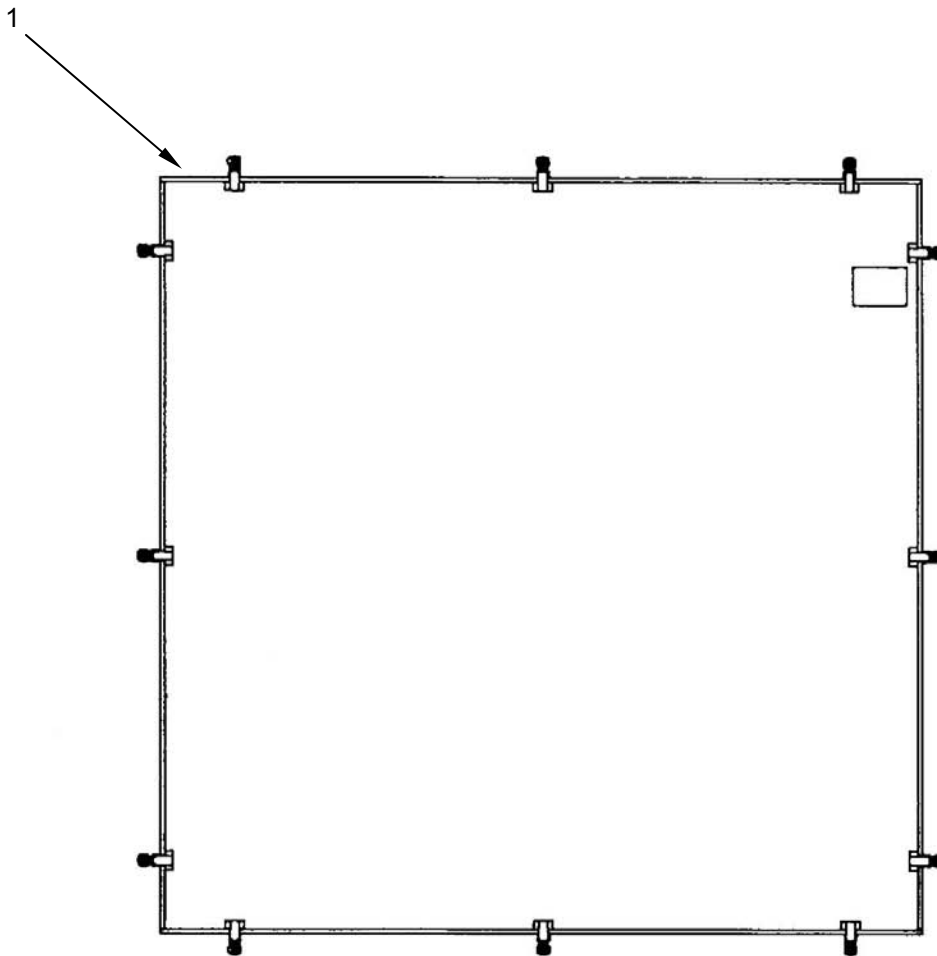

Figure 8. Floor Assembly.

(1) ITEM NO.	(2) SMR CODE	(3) NSN	(4) CAGEC	(5) PART NUMBER	(6) DESCRIPTION AND USABLE ON CODE (UOC)	(7) QTY
					GROUP 0207 FLOOR ASSEMBLY	
					FIG. 8 FLOOR ASSEMBLY	
1	PAOFF	8340-01-331-3304	81337	5-4-6355	FLOOR ASSEMBLY	1
END OF FIGURE						

**OPERATOR, UNIT, AND DIRECT SUPPORT MAINTENANCE
MODULAR COMMAND POST SYSTEM (MCPS), SMALL**

NSN 8340-01-323-2454

NSN 8340-01-334-7529

NSN 8340-01-528-4188

NSN 8340-01-528-8210

PLAIN WALL LINER

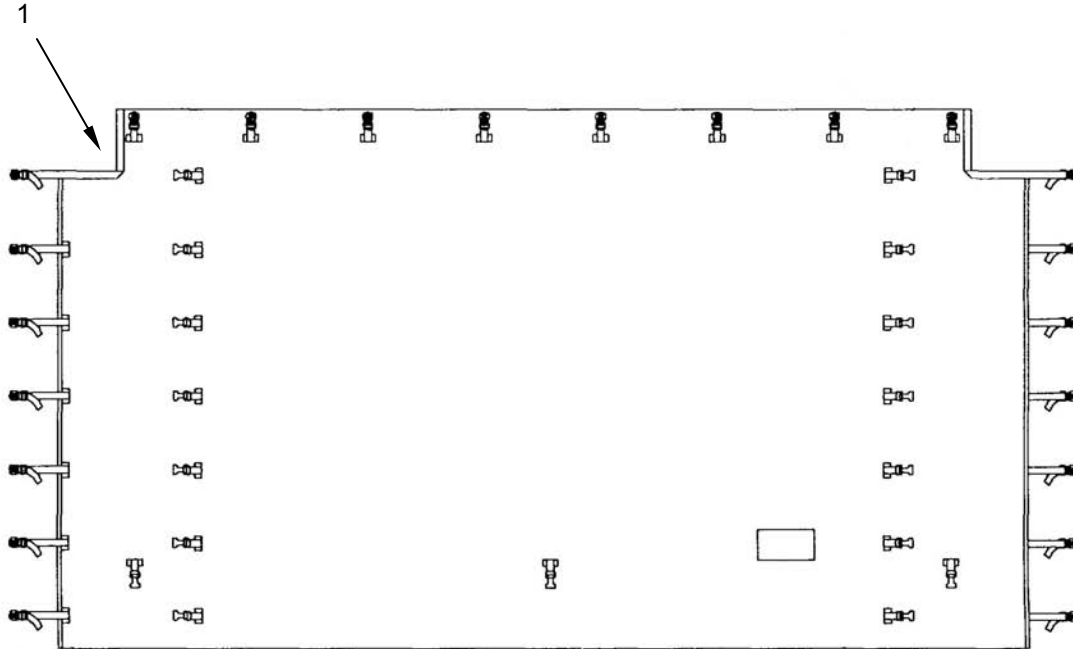

Figure 9. Plain Wall Liner.

(1) ITEM NO.	(2) SMR CODE	(3) NSN	(4) CAGEC	(5) PART NUMBER	(6) DESCRIPTION AND USABLE ON CODE (UOC)	(7) QTY
1	PAOFF	5410-01-333-0661	81337	5-4-6353	GROUP 0208 PLAIN WALL LINER FIG. 9 PLAIN WALL LINER PLAIN WALL LINER UOC: EWG, EZN.....	1
END OF FIGURE						

**OPERATOR, UNIT, AND DIRECT SUPPORT MAINTENANCE
MODULAR COMMAND POST SYSTEM (MCPS), SMALL**

NSN 8340-01-323-2454

NSN 8340-01-334-7529

NSN 8340-01-528-4188

NSN 8340-01-528-8210

ENTRANCE WAY/WINDOW WALL LINER

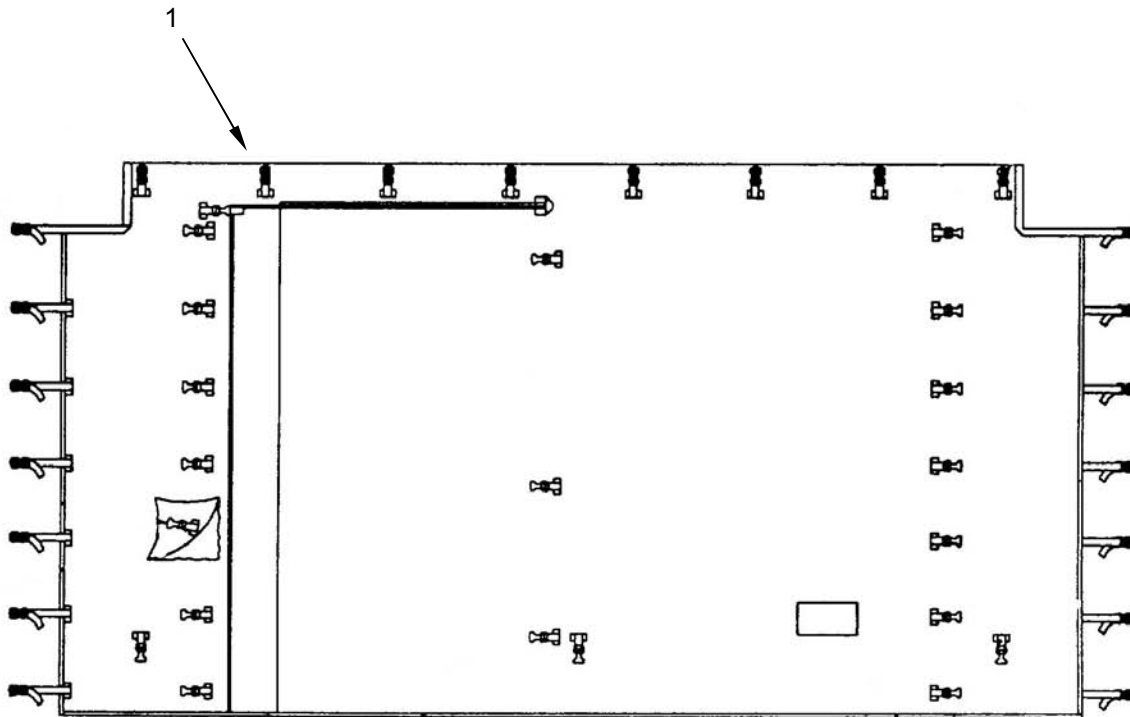

Figure 10. Entrance Way/Window Wall Liner.

(1) ITEM NO.	(2) SMR CODE	(3) NSN	(4) CAGEC	(5) PART NUMBER	(6) DESCRIPTION AND USABLE ON CODE (UOC)	(7) QTY
1	PAOFF	5410-01-331-3303	81337	5-4-6354	GROUP 0209 ENTRANCE WAY/WINDOW WALL LINER FIG. 10 ENTRANCE WAY/WINDOW WALL LINER LINER, ENTRANCE WALL UOC: EWG, EZN	1
END OF FIGURE						

**OPERATOR, UNIT, AND DIRECT SUPPORT MAINTENANCE
MODULAR COMMAND POST SYSTEM (MCPS), SMALL
NSN 8340-01-323-2454
NSN 8340-01-334-7529
NSN 8340-01-528-4188
NSN 8340-01-528-8210**

INSULATED LINER, ECU/WINDOW WALL

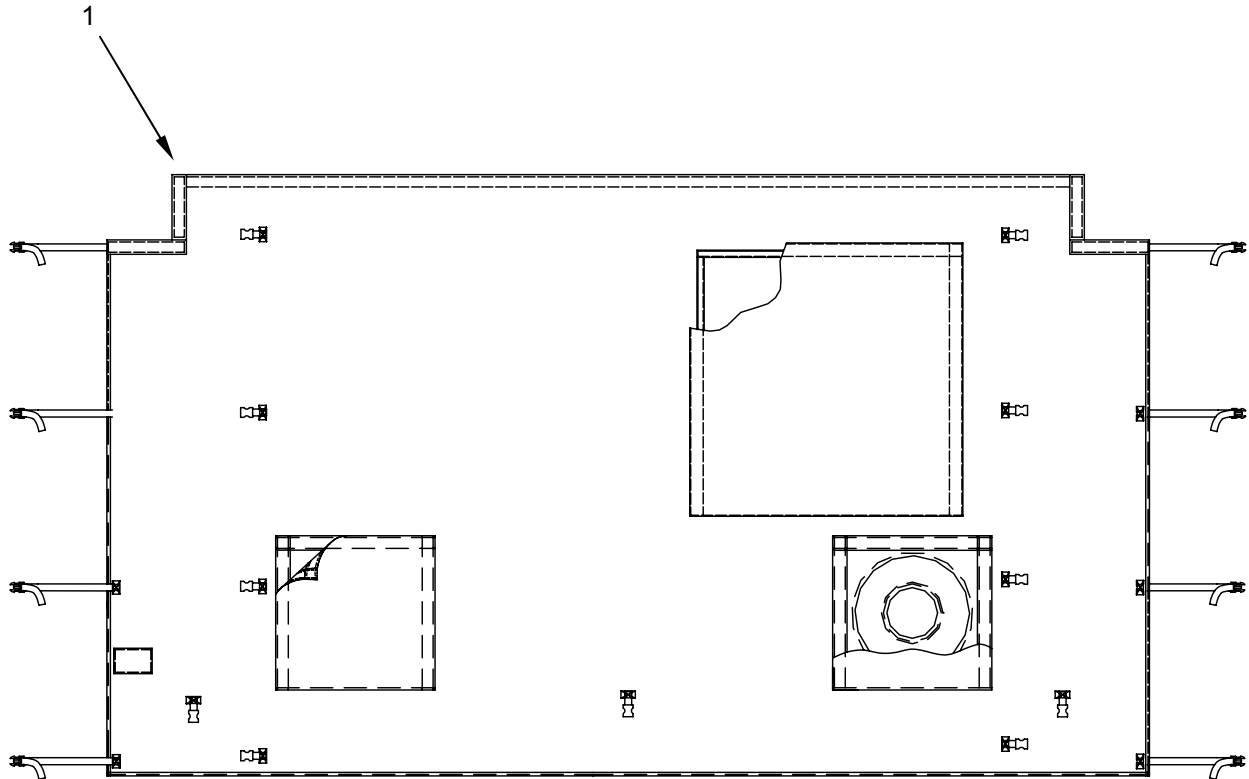

Figure 11. Insulated Liner, ECU/Window Wall.

(1) ITEM NO.	(2) SMR CODE	(3) NSN	(4) CAGEC	(5) PART NUMBER	(6) DESCRIPTION AND USABLE ON CODE (UOC)	(7) QTY
					GROUP 0301 INSULATED LINER, ECU/WINDOW WALL FIG. 11 INSULATED LINER, ECU/WINDOW WALL INSULATED LINER, ECU/WINDOW WALL UOC: FUD, FUE	1
	PAOFF	8340-01-529-6215	81337	5-4-9692-1	END OF FIGURE	

**OPERATOR, UNIT, AND DIRECT SUPPORT MAINTENANCE
MODULAR COMMAND POST SYSTEM (MCPS), SMALL**

NSN 8340-01-323-2454

NSN 8340-01-334-7529

NSN 8340-01-528-4188

NSN 8340-01-528-8210

INSULATED LINER, ENTRANCE WAY

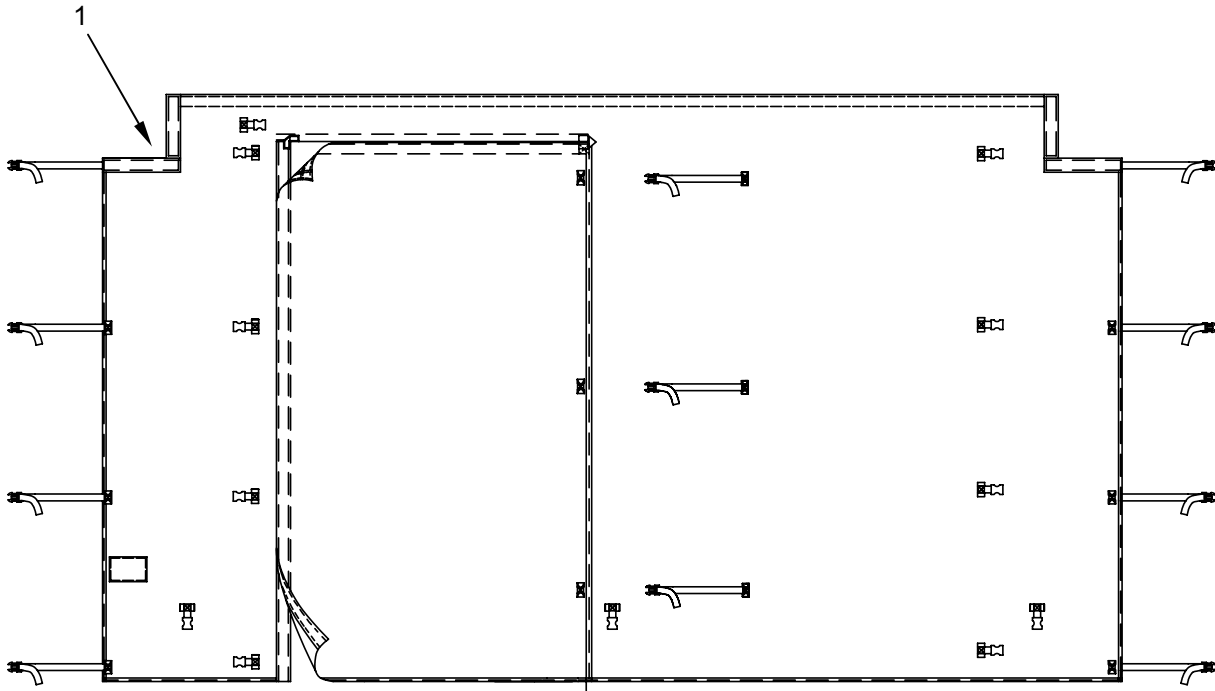

Figure 12. Insulated Liner, Entrance Way.

(1) ITEM NO.	(2) SMR CODE	(3) NSN	(4) CAGEC	(5) PART NUMBER	(6) DESCRIPTION AND USABLE ON CODE (UOC)	(7) QTY
1	PAOFF	8340-01-524-8009	81337	5-4-9065-1	GROUP 0302 INSULATED LINER, ENTRANCE WAY FIG. 12 INSULATED LINER, ENTRANCE WAY LINER, INSULATED, EXTERIOR WALL UOC: FUD, FUE	1
END OF FIGURE						

OPERATOR, UNIT, AND DIRECT SUPPORT MAINTENANCE
MODULAR COMMAND POST SYSTEM (MCPS), SMALL

NSN 8340-01-323-2454

NSN 8340-01-334-7529

NSN 8340-01-528-4188

NSN 8340-01-528-8210

INSULATED LINER, BOOT WALL ASSEMBLY

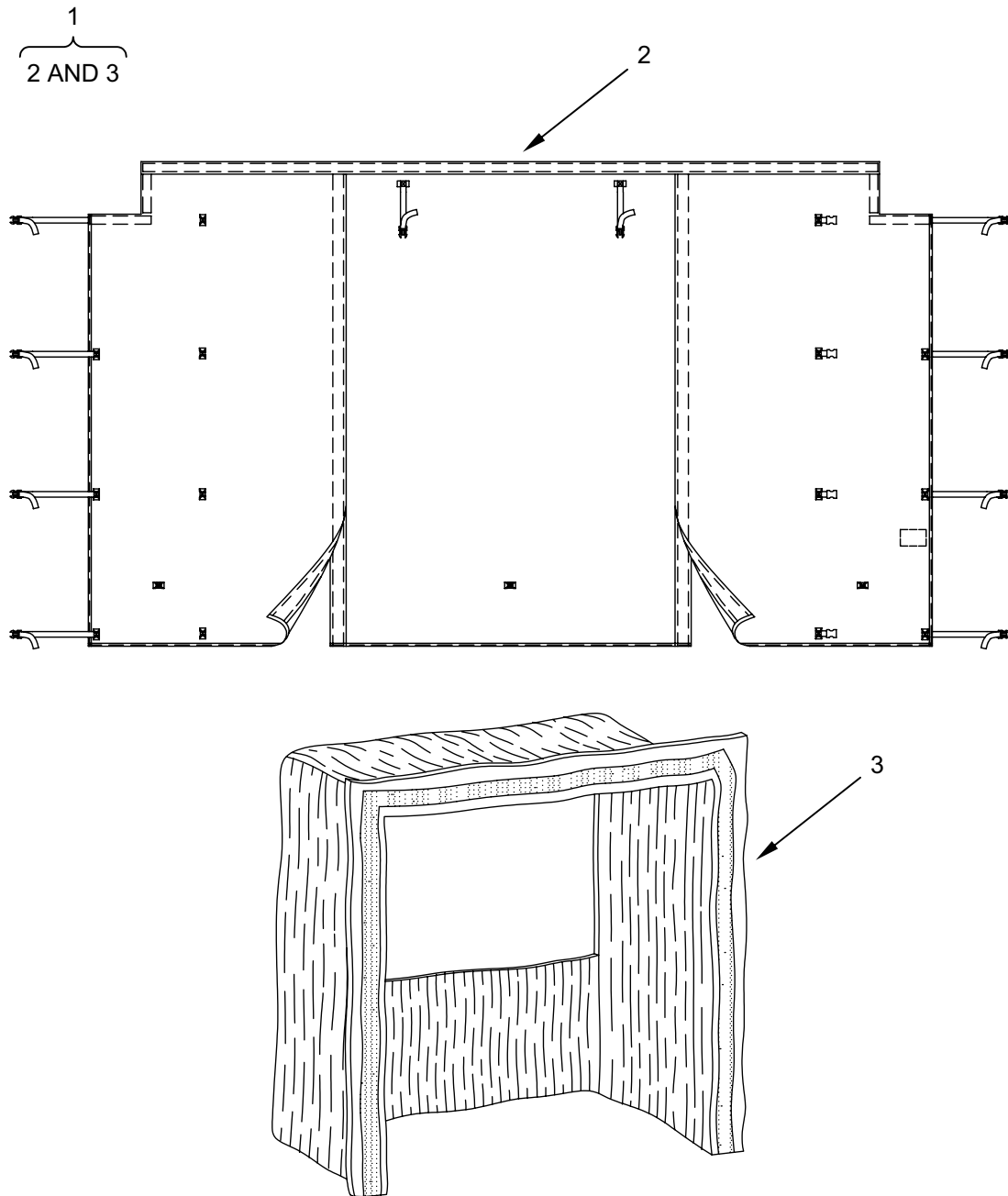

Figure 13. Insulated Liner, Boot Wall Assembly.

(1) ITEM NO.	(2) SMR CODE	(3) NSN	(4) CAGEC	(5) PART NUMBER	(6) DESCRIPTION AND USABLE ON CODE (UOC)	(7) QTY
					GROUP 0303 INSULATED LINER, BOOT WALL ASSEMBLY	
					FIG. 13 INSULATED LINER, BOOT WALL ASSEMBLY	
1	PAOFF	8340-01-524-8042	81337	5-4-9061	LINER, INSULATED, KIT, BOOT WALL ASSEMBLY	
					UOC: FUD, FUE	1
2	XAOFF		81337	5-4-9062-1	.INSULATED LINER, BOOTWALL	
					UOC: FUD, FUE	1
3	XAOFF		81337	5-4-9063-1	.INSULATED LINER, BOOTWALL, RWS	
					UOC: FUD, FUE	1
END OF FIGURE						

OPERATOR, UNIT, AND DIRECT SUPPORT MAINTENANCE
MODULAR COMMAND POST SYSTEM (MCPS), SMALL
NSN 8340-01-323-2454
NSN 8340-01-334-7529
NSN 8340-01-528-4188
NSN 8340-01-528-8210

INSULATED LINER, ROOF CAP ASSEMBLY

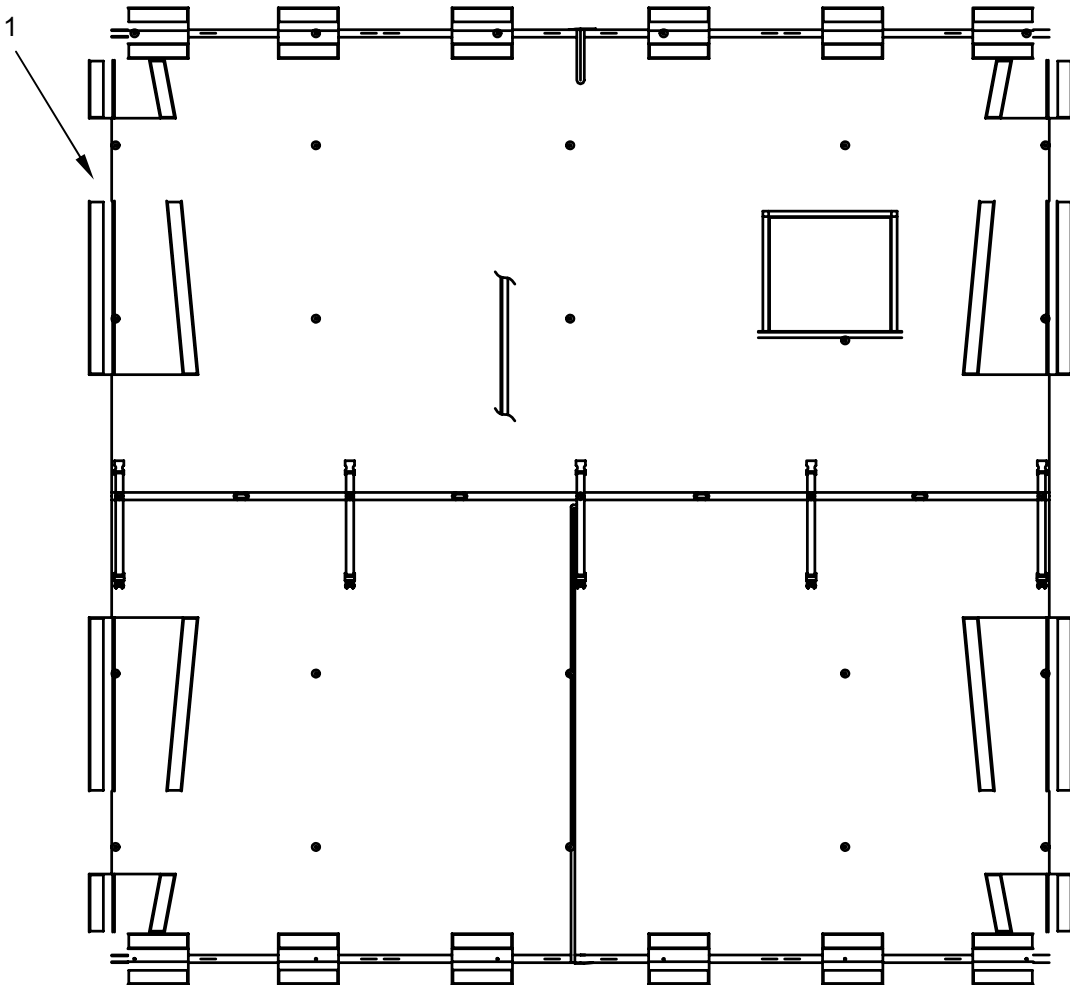

Figure 14. Insulated Liner, Roof Cap Assembly.

(1) ITEM NO.	(2) SMR CODE	(3) NSN	(4) CAGEC	(5) PART NUMBER	(6) DESCRIPTION AND USABLE ON CODE (UOC)	(7) QTY
1	PAOFF	8340-01-524-8038	81337	5-4-9067-1	GROUP 0304 INSULATED LINER, ROOF CAP ASSEMBLY FIG. 14 INSULATED LINER, ROOF CAP ASSEMBLY LINER, INSULATED, ROOF CAP UOC: FUD, FUE	1
END OF FIGURE						

OPERATOR, UNIT, AND DIRECT SUPPORT MAINTENANCE
MODULAR COMMAND POST SYSTEM (MCPS), SMALL
NSN 8340-01-323-2454
NSN 8340-01-334-7529
NSN 8340-01-528-4188
NSN 8340-01-528-8210

INSULATED LINER, RAIN GUTTER ASSEMBLY

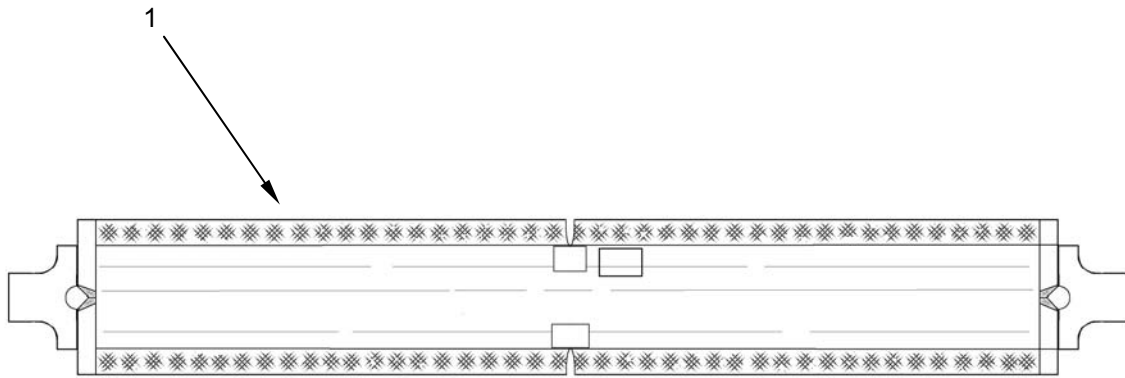

Figure 15. Insulated Liner, Rain Gutter Assembly.

(1) ITEM NO.	(2) SMR CODE	(3) NSN	(4) CAGEC	(5) PART NUMBER	(6) DESCRIPTION AND USABLE ON CODE (UOC)	(7) QTY
1	PAOFF	8340-01-524-8037	81337	5-4-9068-1	GROUP 0305 INSULATED LINER, RAIN GUTTER ASSEMBLY FIG. 15 INSULATED LINER, RAIN GUTTER ASSEMBLY LINER, INSULATED, RAIN GUTTER UOC: FUD, FUE	1
END OF FIGURE						

OPERATOR, UNIT, AND DIRECT SUPPORT MAINTENANCE
MODULAR COMMAND POST SYSTEM (MCPS), SMALL

NSN 8340-01-323-2454

NSN 8340-01-334-7529

NSN 8340-01-528-4188

NSN 8340-01-528-8210

TABLE, FIELD, FOLDING LEGS, METAL

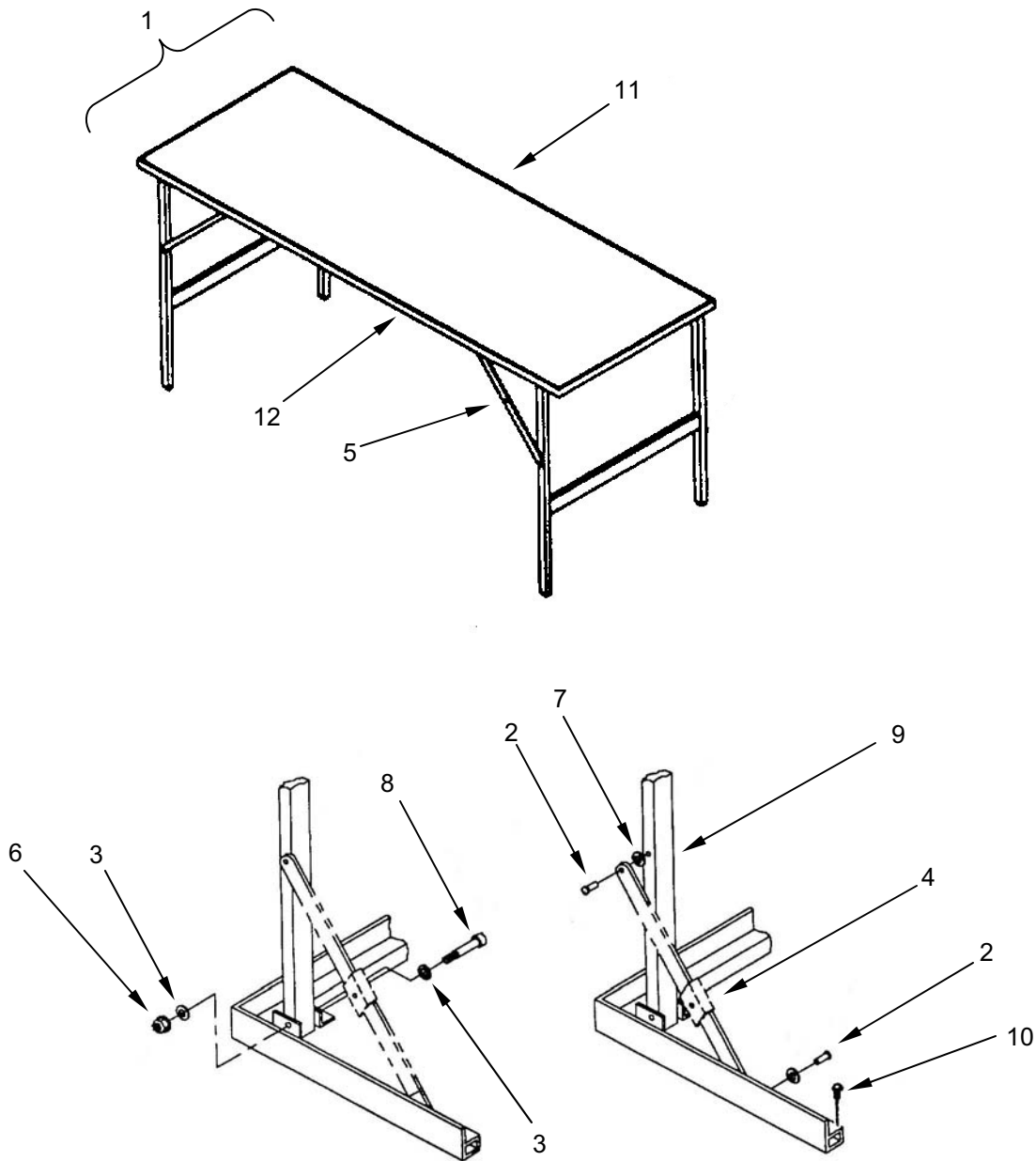

Figure 16. Table, Field, Folding Legs, Metal.

(1) ITEM NO.	(2) SMR CODE	(3) NSN	(4) CAGEC	(5) PART NUMBER	(6) DESCRIPTION AND USABLE ON CODE (UOC)	(7) QTY
					GROUP 04 TABLE, FIELD, FOLDING LEGS, METAL	
					FIG. 16 TABLE, FIELD, FOLDING LEGS, METAL	
1	PAOOO	8340-01-327-7685	81337	5-13-4661	TABLE, FOLDING, TENT	2
2	PAOZZ	5320-00-850-3256	07707	AD86BS	.RIVET, BLIND	8
3	PAOZZ	5310-00-533-9328	96906	MS51859-7	.WASHER, FLAT, NYLON.....	8
4	PAOZZ	5410-01-330-5146	81337	5-13-4668-1	.STOP, LEG BRACE, FIELD	2
5	PAOZZ	5410-01-331-7324	81337	5-13-4668-2	.STRAP, LEG BRACE, FIELD	2
6	PAOZZ	5310-00-929-1807	81349	M45913/1-4CS3	.NUT, SELF-LOCKING, HEX.....	4
7	PAOZZ	5310-00-502-0106	1YGB8	2326-N-253	.WASHER, FLAT	8
8	PAOZZ	5305-00-935-2985	80205	MS51975-15	.SCREW, SHOULDER	4
9	PAOZZ	7195-01-328-1987	81337	5-13-4662-1	.LEG ASSEMBLY, WORK TABLE...	2
10	PAOZZ	5305-00-115-9984	96906	MS35492-78	.SCREW, WOOD	8
11	XAOZZ		81337	5-13-4671-1	.SPECIFICATION PANEL	1
12	XAOZZ		81337	5-13-4664-1	.WELDMENT, FRAME.....	1
END OF FIGURE						

OPERATOR, UNIT, AND DIRECT SUPPORT MAINTENANCE
MODULAR COMMAND POST SYSTEM (MCPS), SMALL

NSN 8340-01-323-2454

NSN 8340-01-334-7529

NSN 8340-01-528-4188

NSN 8340-01-528-8210

COMPLEXING MAP BOARD

1
2 THROUGH 18

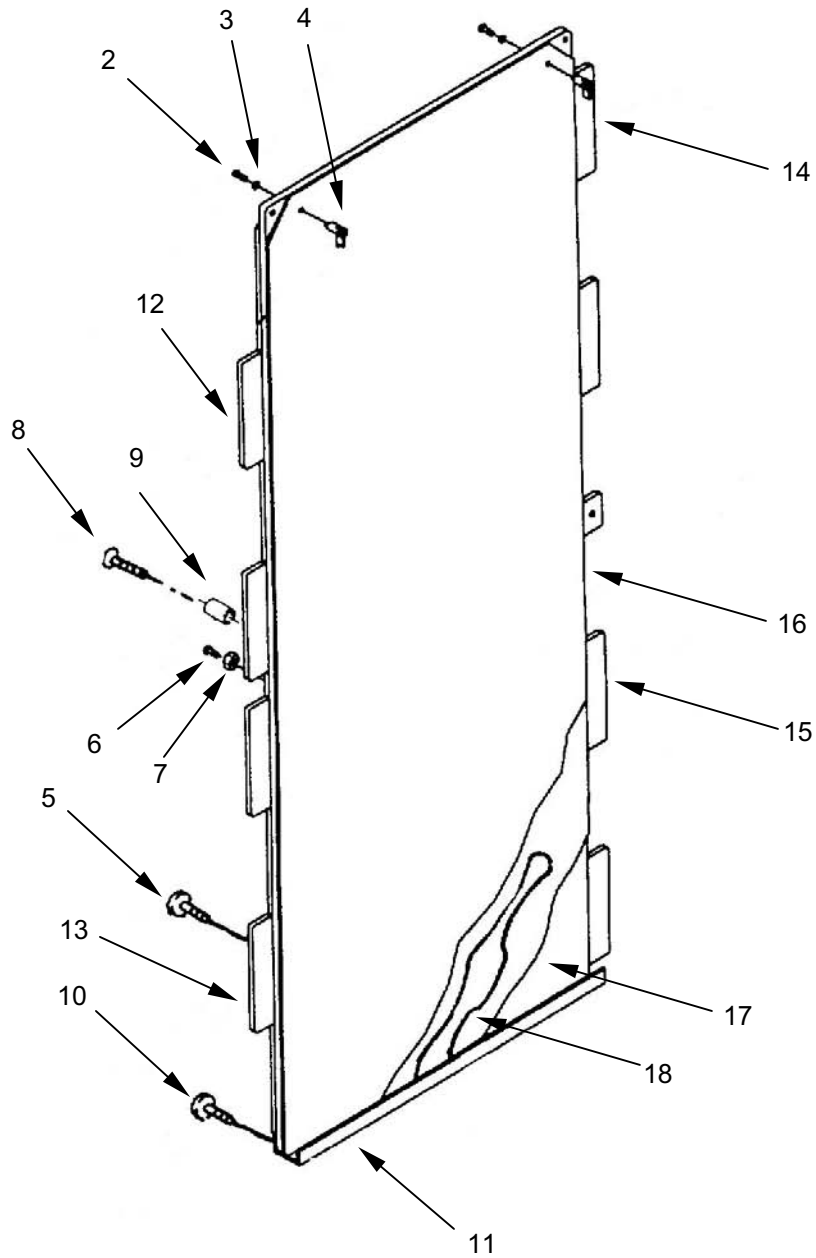

Figure 17. Complexing Map Board.

(1) ITEM NO.	(2) SMR CODE	(3) NSN	(4) CAGEC	(5) PART NUMBER	(6) DESCRIPTION AND USABLE ON CODE (UOC)	(7) QTY
					GROUP 05 COMPLEXING MAP BOARD	
					FIG. 17 COMPLEXING MAP BOARD	
1	PAOZZ	8340-01-327-6124	81337	5-4-7457	MAPBOARD	4
2	PAOZZ	5305-00-071-1315	96906	MS51957-79	.SCREW, MACHINE.....	2
3	PAOZZ	5310-00-933-8121	80205	MS35338-139	.WASHER, LOCK	2
4	PAOZZ	7110-01-327-6139	81337	5-4-7458	.LOCATOR, CYLINDER ASSEMBLY	2
5	PAOZZ	5305-00-900-2545	96906	MS35492-27	.SCREW, WOOD.....	5
6	PAOZZ	5305-00-701-5075	95105	342-0100-00	.SCREW, MACHINE.....	10
7	PAOZZ	5310-00-492-6079	96906	MS51941-5	.NUT, PLAIN, PLATE	4
8	PAOZZ	5305-00-701-5071	96906	MS51959-61	.SCREW, MACHINE.....	1
9	XBOZZ		81337	5-4-7469	.SPACER.....	1
10	PAOZZ	5305-00-249-2665	96906	MS35494-32	.WOOD SCREW, FLAT HD.....	18
11	XBOZZ		81337	5-4-7468	.CHANNEL	1
12	XBOZZ		81337	5-4-7459	.COMPLEXER TOP, LEFT	1
13	XBOZZ		81337	5-4-7460	.COMPLEXER BOTTOM, LEFT	1
14	XBOZZ		81337	5-4-7461	.COMPLEXER TOP, RIGHT.....	1
15	XBOZZ		81337	5-4-7462	.COMPLEXER BOTTOM, RIGHT.....	1
16	PAOZZ	7110-01-327-6141	81337	5-4-7467	.OVERLAY, RIGID, MAPBOARD	1
17	XAOZZ		81337	5-4-8496	.OVERLAY, ROLLABLE	1
18	XAOZZ		81337	5-4-7465	.MAPBOARD PANEL	1
END OF FIGURE						

OPERATOR, UNIT, AND DIRECT SUPPORT MAINTENANCE
MODULAR COMMAND POST SYSTEM (MCPS), SMALL

NSN 8340-01-323-2454

NSN 8340-01-334-7529

NSN 8340-01-528-4188

NSN 8340-01-528-8210

LIGHT ASSEMBLY

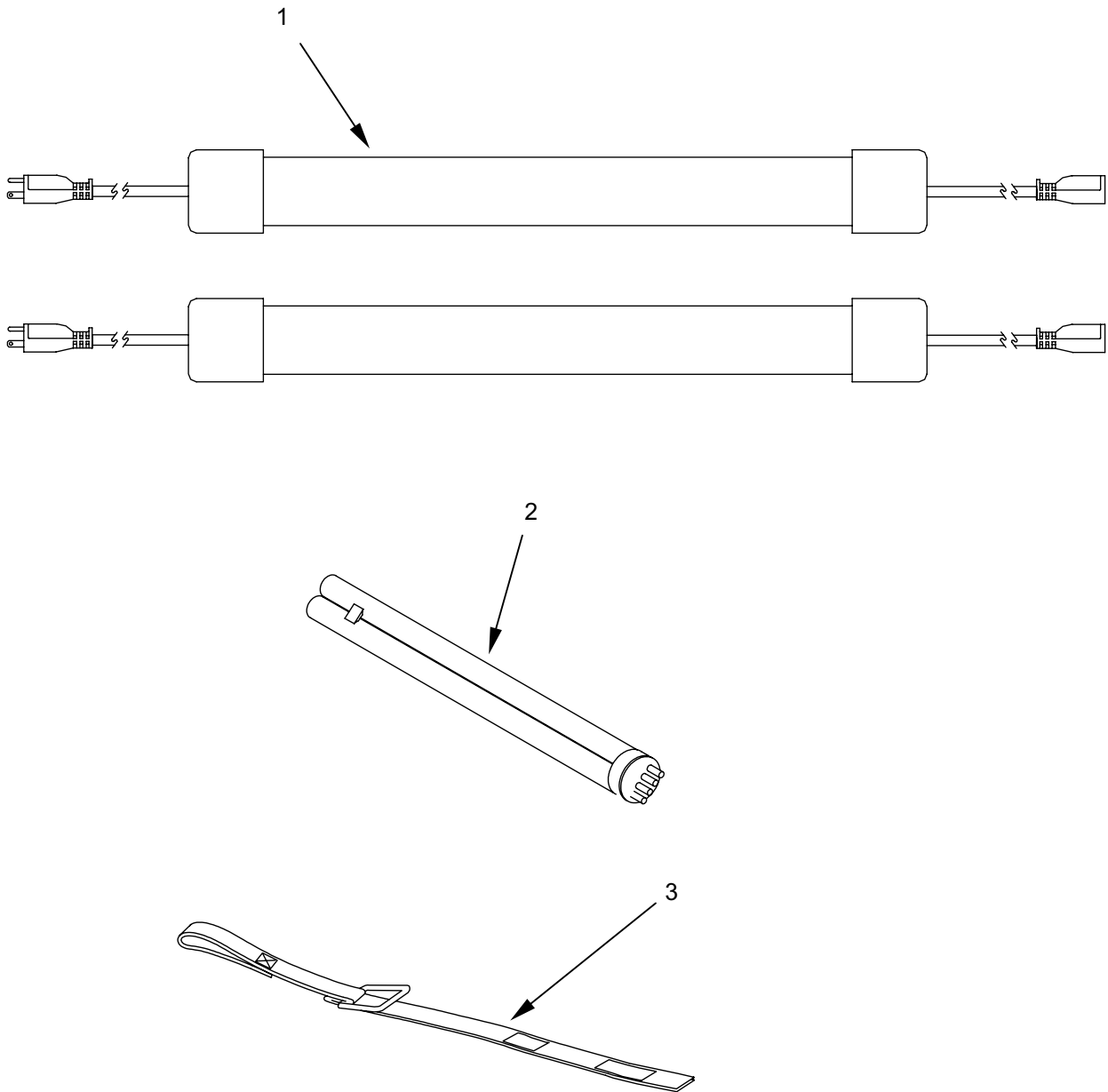

Figure 18. Light Assembly.

(1) ITEM NO.	(2) SMR CODE	(3) NSN	(4) CAGEC	(5) PART NUMBER	(6) DESCRIPTION AND USABLE ON CODE (UOC)	(7) QTY
					GROUP 06 LIGHT ASSEMBLY	
					FIG. 18 LIGHT ASSEMBLY	
1	PAOOO	6230-01-465-8931	06969	F131-502SK	LIGHT SET, GENERAL ILLUMINATION	1
2	PAOZZ	6240-01-477-9718	81337	5-4-8745	.BULB, 50 WATT, DOUBLE TUBE, 4 PIN	1
3	PAOZZ	5340-01-475-8205	80515	CMC-7971	.LIGHT SUPPORT STRAP ASSEMBLY	1
					END OF FIGURE	

**OPERATOR, UNIT, AND DIRECT SUPPORT MAINTENANCE
MODULAR COMMAND POST SYSTEM (MCPS), SMALL**

NSN 8340-01-323-2454

NSN 8340-01-334-7529

NSN 8340-01-528-4188

NSN 8340-01-528-8210

TRANSPORT BAG ASSEMBLY - FRAME

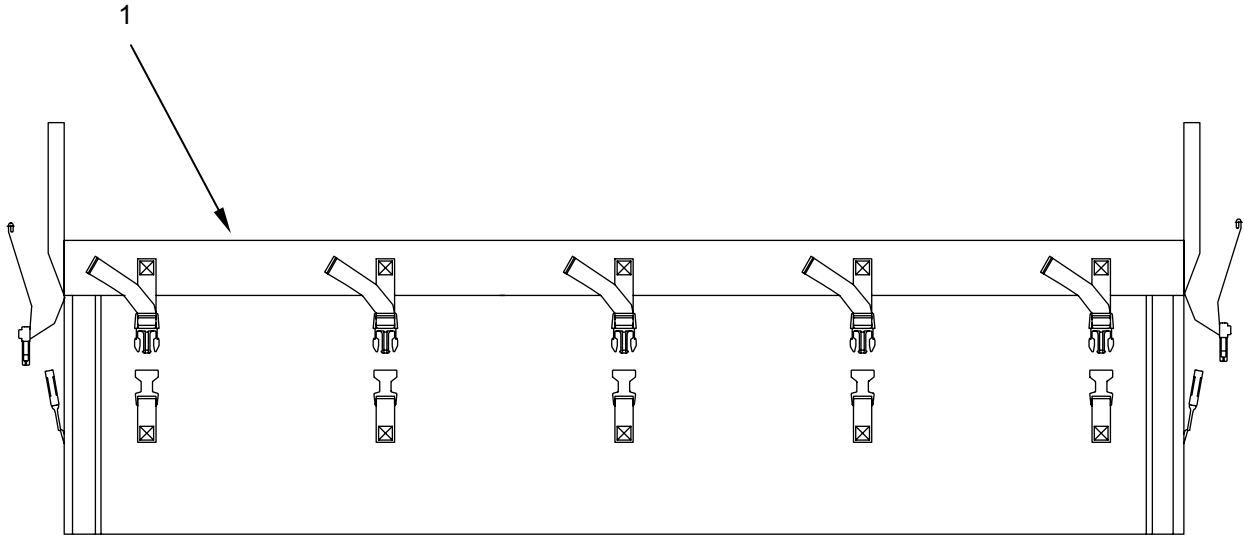

Figure 19. Transport Bag Assembly – Frame.

(1) ITEM NO.	(2) SMR CODE	(3) NSN	(4) CAGEC	(5) PART NUMBER	(6) DESCRIPTION AND USABLE ON CODE (UOC)	(7) QTY
					GROUP 07 TRANSPORT BAG ASSEMBLY - FRAME	
					FIG. 19 TRANSPORT BAG ASSEMBLY - FRAME	
1	PAOFF	8340-01-337-5561	81337	5-4-7474-1	TRANSPORT BAG ASSEMBLY – FRAME, CAMOUFLAGE GREEN UOC: EWG, FUD	1
1	PAOFF	8340-01-336-9093	81337	5-4-7474-2	TRANSPORT BAG ASSEMBLY – FRAME, DESERT TAN UOC: EZN, FUE	1
END OF FIGURE						

**OPERATOR, UNIT, AND DIRECT SUPPORT MAINTENANCE
MODULAR COMMAND POST SYSTEM (MCPS), SMALL
NSN 8340-01-323-2454
NSN 8340-01-334-7529
NSN 8340-01-528-4188
NSN 8340-01-528-8210**

TRANSPORT BAG ASSEMBLY - FABRIC

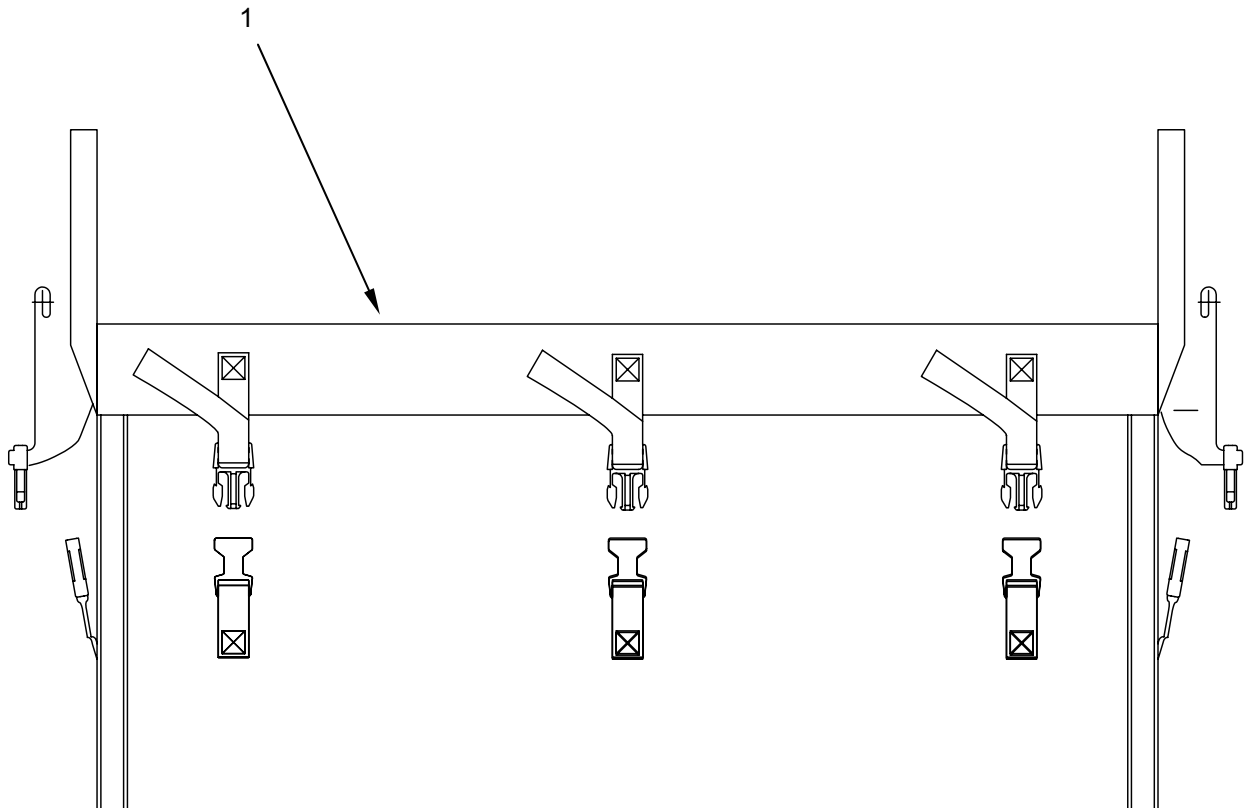

Figure 20. Transport Bag Assembly – Fabric.

(1) ITEM NO.	(2) SMR CODE	(3) NSN	(4) CAGEC	(5) PART NUMBER	(6) DESCRIPTION AND USABLE ON CODE (UOC)	(7) QTY
					GROUP 08 TRANSPORT BAG ASSEMBLY - FABRIC	
					FIG. 20 TRANSPORT BAG ASSEMBLY - FABRIC	
1	PAOFF	8340-01-337-7234	81337	5-4-7476-1	TRANSPORT BAG ASSEMBLY – FABRIC, CAMOUFLAGE GREEN UOC: EWG, FUD	5
1	PAOFF	8340-01-337-9215	81337	5-4-7476-2	TRANSPORT BAG ASSEMBLY – FABRIC, DESERT TAN UOC: EZN, FUE	5
END OF FIGURE						

**OPERATOR, UNIT, AND DIRECT SUPPORT MAINTENANCE
MODULAR COMMAND POST SYSTEM (MCPS), SMALL
NSN 8340-01-323-2454
NSN 8340-01-334-7529
NSN 8340-01-528-4188
NSN 8340-01-528-8210**

VESTIBULE/PIN CONTAINER

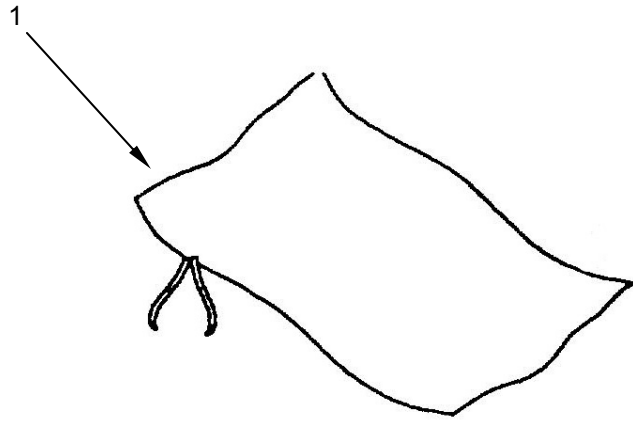

Figure 21. Vestibule/Pin Container.

(1) ITEM NO.	(2) SMR CODE	(3) NSN	(4) CAGEC	(5) PART NUMBER	(6) DESCRIPTION AND USABLE ON CODE (UOC)	(7) QTY
					GROUP 09 VESTIBULE/PIN CONTAINER	
					FIG. 21 VESTIBULE/PIN CONTAINER	
1	PAOZZ	8340-01-186-3030	81337	5-4-8487-1	VESTIBULE/PIN CONTAINER CAMOUFLAGE GREEN UOC: EWG, FUD	1
1	PAOZZ	8340-01-440-8886	81337	5-4-8487-2	VESTIBULE/PIN CONTAINER DESERT TAN UOC: EZN, FUE	1
END OF FIGURE						

**OPERATOR, UNIT, AND DIRECT SUPPORT MAINTENANCE
MODULAR COMMAND POST SYSTEM (MCPS), SMALL
NSN 8340-01-323-2454
NSN 8340-01-334-7529
NSN 8340-01-528-4188
NSN 8340-01-528-8210**

REPAIR PARTS FOR SPECIAL TOOLS

There are no special tools supplied or required for the MCPS Small.

**OPERATOR, UNIT, AND DIRECT SUPPORT MAINTENANCE
MODULAR COMMAND POST SYSTEM (MCPS), SMALL**

NSN 8340-01-323-2454

NSN 8340-01-334-7529

NSN 8340-01-528-4188

NSN 8340-01-528-8210

BULK MATERIAL

(1) ITEM NO.	(2) SMR CODE	(3) NSN	(4) CAGEC	(5) PART NUMBER	(6) DESCRIPTION AND USABLE ON CODE (UOC)	(7) QTY
GROUP BULK MATERIAL						
FIG. BULK						
1	XBOZZ	8305-01-238-0342	81349	MIL-PRF-44103	CLOTH, DUCK, POLY, GREEN UOC: EWG, FUD.....	V
2	XBOZZ	8305-01-238-8076	81337	MIL-PRF-44103	CLOTH, DUCK, POLY, TAN UOC: EZN, FUE.....	V
3	PAOZZ	8305-01-225-9231	81349	MIL-C-43774	CLOTH, PAJAMA CHECK	V
4	PAOZZ	8305-01-030-7235	81349	MIL-C-5651	CORD, ELASTIC	V
5	PAOZZ		81349	MIL-F- 21840TYII	FASTENER TAPE, HOOK, 1 INCH, OD CLASS 3	V
6	PAOZZ		81349	MIL-F- 21840TYII	FASTENER TAPE, HOOK, 2 INCH, OD CLASS 3 UOC: EWG, FUD.....	V
7	PAOZZ		81349	MIL-F- 21840TYII	FASTENER TAPE, PILE, 1 INCH, OD CLASS 3 UOC: EWG, FUD.....	V
8	PAOZZ		81349	MIL-F- 21840TYII	FASTENER TAPE, PILE, 1 INCH, OD CLASS 3 UOC: EZN, FUE.....	V
9	PAOZZ		81349	MIL-F- 21840TYII	FASTENER TAPE, PILE, 2 INCH, WHITE CLASS 3 UOC: EZN, FUE.....	V
10	PAOZZ		81349	MIL-F- 21840TYII	FASTENER TAPE,HOOK, 2 INCH, WHITE CLASS 3 UOC: EZN, FUE.....	V
11	PAOZZ		81349	MIL-F- 21840TYII	FASTENER TAPE, PILE, 2 INCH, OD CLASS 3 UOC: EWG, FUD.....	V
12	PAOZZ	8465-01-286-5352	81337	5-10-47	FASTENER, QUICK RELEASE, 1 INCH, BLACK	V
13	PAOZZ		81349	MIL-L-1709 TYXXVI	LINE,TENT.....	V
14	PAFZZ		81348	LP378TYI	PLASTIC SHEET	V
15	PAOZZ		81349	MIL-R-30500	ROPE, FIBROUS, 3/8 INCH DIA, NATURAL	V
16	PAOZZ		81348	LS125	SCREENING,INSECT, NO	V
17			81349	MIL-T- 5038TYII, CLASS 2	TAPE, REINFOR, NYLON 1 INCH, OD UOC: EWG, FUD.....	V
18	PAOZZ		81349	MIL-T- 5038TYII, CLASS 2	TAPE,REINFOR,NYLON 1 INCH, TAN UOC: EZN, FUE.....	V

(1) ITEM NO.	(2) SMR CODE	(3) NSN	(4) CAGEC	(5) PART NUMBER	(6) DESCRIPTION AND USABLE ON CODE (UOC)	(7) QTY
19	PAOZZ		81349	MIL-T-43566TYI, CLASS 4	TAPE,TEXTILE, 1 INCH, OD UOC: EWG, FUD.....	V
20	PAOZZ		81349	MIL-T-43566TYI, CLASS 4	TAPE,TEXTILE, 1 INCH, TAN UOC: EZN, FUE.....	V
21	PAOZZ		81349	MIL-T-43566TYI, CLASS 4	TAPE,TEXTILE, 2 INCH, OD UOC: EWG, FUD.....	V
22	PAOZZ		81349	MIL-T-43566TYI, CLASS 4	TAPE,TEXTILE, 2 INCH, TAN UOC: EZN, FUE.....	V
23	PAOZZ		81349	MIL-T-43566TYI, CLASS 4	TAPE,TEXTILE, 3/4 INCH, OD UOC: EWG, FUD.....	V
24	PAOZZ		81349	MIL-T-43566TYI, CLASS 4	TAPE,TEXTILE, 3/4 INCH, TAN UOC: EZN, FUE.....	V
25	PAOZZ		81348	V-T-285TYI, CLASS 1, SUBCLASS B	THREAD, POLY, OD, F UOC: EWG, FUD.....	V
26	PAOZZ		81348	V-T-285TYI, CLASS 1, SUBCLASS B	THREAD, POLY, OD, FF UOC: EWG, FUD.....	V
27	PAOZZ		81348	V-T-285TYI, CLASS 1, SUBCLASS B	THREAD, POLY, TAN, F UOC: EZN, FUE.....	V
28	PAOZZ		81348	V-T-285TYI, CLASS 1, SUBCLASS B	THREAD, POLY, TAN, FF UOC: EZN, FUE.....	V
29	PAOZZ		81349	MIL-W-4088 TYVIII B, CLASS 2	WEBBING,NYLON, 2 INCH, OD UOC: EWG, FUD.....	V
30	PAOZZ		81349	MIL-W-4088 TYVIII B, CLASS 2	WEBBING,NYLON, 2 INCH, TAN UOC: EZN, FUE.....	V
31	PAOZZ		81349	MIL-W-530 TYIIA, CLASS 4	WEBBING,NYLON, 2 INCH, OD UOC: EWG, FUD.....	V
32	PAOZZ		81349	MIL-W-530 TYIIA, CLASS 4	WEBBING,NYLON, 2 INCH, TAN UOC: EZN, FUE.....	V
33	PAOZZ		81349	MIL-W-4088 TYVIII, CLASS 2	WEBBING,NYLON, 23/32 INCH, OD UOC: EWG, FUD.....	V
34	PAOZZ		81349	MIL-W-4088 TYVIII, CLASS 2	WEBBING,NYLON, 23/32 INCH, TAN UOC: EZN, FUE.....	V

(1) ITEM NO.	(2) SMR CODE	(3) NSN	(4) CAGEC	(5) PART NUMBER	(6) DESCRIPTION AND USABLE ON CODE (UOC)	(7) QTY
35	PAOZZ		81349	MIL-T-5038 TYII, CLASS 2	WEBBING,TEXTILE 1 1/2 INCH, OD UOC: EWG, FUD.....	V
36	PAOZZ		81349	MIL-T-5038 TYII, CLASS 2	WEBBING,TEXTILE 1 1/2 INCH, TAN UOC: EZN, FUE.....	V
37	PAOZZ		81349	MIL-T- 5038TYII, CLASS 2	WEBBING,TEXTILE 1 INCH, OD UOC: EWG, FUD.....	V
38	PAOZZ		81349	MIL-W-43668 TYIII	WEBBING,TEXTILE 1 INCH, OD UOC: EWG, FUD.....	V
39	PAOZZ		81349	MIL-T-5038 TYII, CLASS 2	WEBBING,TEXTILE 1 INCH, TAN UOC: EZN, FUE.....	V
40	PAOZZ		81349	MIL-W-43668 TYIII	WEBBING,TEXTILE 1 INCH, TAN UOC: EZN, FUE.....	V
41	PAOZZ		81349	MIL-T-5038 TYII,CLASS 2	WEBBING,TEXTILE 2 INCH, OD UOC: EWG, FUD.....	V
42	PAOZZ		81349	MIL-T-5038 TYII, CLASS 2	WEBBING,TEXTILE 2 INCH, TAN UOC: EZN, FUE.....	V
43	PAOZZ		81349	MIL-W-4088 TYVIII, CLASS 2	WEBBING,TEXTILE, 1 INCH, OD UOC: EWG, FUD.....	V
44	PAOZZ		81349	MIL-W-4088 TYXX, CLASS 2	WEBBING,TEXTILE, 1 INCH, OD UOC: EWG, FUD.....	V
45	PAOZZ		81349	MIL-W-4088 TYXX, CLASS 2	WEBBING,TEXTILE, 1 INCH, TAN UOC: EZN, FUE.....	V
END OF FIGURE						

**OPERATOR, UNIT, AND DIRECT SUPPORT MAINTENANCE
 MODULAR COMMAND POST SYSTEM (MCPS), SMALL
 NSN 8340-01-323-2454
 NSN 8340-01-334-7529
 NSN 8340-01-528-4188
 NSN 8340-01-528-8210**

NSN INDEX

STOCK NUMBER	FIG.	ITEM	STOCK NUMBER	FIG.	ITEM
5305- 00-071-1315	17	2	5410- 01-331-3303	10	1
5305- 00-115-9984	16	10	8340- 01-331-3304	8	1
8340- 00-205-2759	6	3	8340- 01-331-5422	6	1
5305- 00-249-2665	17	10	5410- 01-331-7324	16	5
5310- 00-492-6079	17	7	5410- 01-331-7325	1	17
5310- 00-502-0106	16	7	5410- 01-332-7684	1	5
5310- 00-533-9328	16	3	5410- 01-332-7685	1	23
5305- 00-701-5071	17	8	5410- 01-332-7686	1	26
5305- 00-701-5075	17	6	5410- 01-333-0661	9	1
5320- 00-850-3256	16	2	5340- 01-333-4114	1	6
5305- 00-900-2545	17	5		1	10
5310- 00-914-6028	1	12		1	25
	1	34		1	28
5310- 00-929-1807	16	6		1	33
5310- 00-933-8121	17	3	8340- 01-333-4126	1	2
5305- 00-935-2985	16	8	8340- 01-333-4718	2	1
8305- 01-0307235	BULK	4	5410- 01-333-4719	1	8
8340- 01-186-3030	21	1		1	29
8305- 01-225-9231	BULK	3	5410- 01-333-5918	1	4
8305- 01-238-0342	BULK	1		1	22
8305- 01-238-8076	BULK	2	5340- 01-333-8474	1	15
5360- 01-250-6959	1	16		1	37
	1	38	3020- 01-333-9193	1	7
8465- 01-286-5352	BULK	12		1	9
8340- 01-327-6124	17	1		1	24
7110- 01-327-6139	17	4		1	27
7110- 01-327-6141	17	16		1	32
8340- 01-327-7685	16	1	8340- 01-334-2341	1	1
5340- 01-327-9355	1	14	8340- 01-336-9093	19	1
	1	36	8340- 01-337-5297	2	1
7195- 01-328-1987	16	9	8340- 01-337-5298	3	1
3040- 01-328-8016	1	30	8340- 01-337-5299	5	1
5410- 01-330-5146	16	4	8340- 01-337-5300	6	1
8340- 01-331-0152	3	1	8340- 01-337-5561	19	1
8340- 01-331-0153	7	1	8340- 01-337-5699	7	1
5410- 01-331-0155	1	3	8340- 01-337-7234	20	1
6150- 01-331-2374	1	39	8340- 01-337-9215	20	1
	1	19	5305- 01-423-5369	1	35
5410- 01-331-3285	1	11		1	13
5410- 01-331-3288	1	18	8340- 01-440-8886	21	1
	1	31	6230-01-465-8931	18	1
5410- 01-331-3289	1	21	5340- 01-475-8205	18	3
8340- 01-331-3302	5	1	5306- 01-475-9900	1	42

STOCK NUMBER	FIG.	ITEM	STOCK NUMBER	FIG.	ITEM
6240-01-477-9718	18	2	8340-01-529-0590	4	1
8340-01-524-8009	12	1	8340-01-529-0596	4	1
8340-01-524-8037	15	1	8340-01-529-6215	11	1
8340-01-524-8038	14	1			
8340-01-524-8042	13	1			
8340-01-524-8052	1	41			

END OF WORK PACKAGE

**OPERATOR, UNIT, AND DIRECT SUPPORT MAINTENANCE
MODULAR COMMAND POST SYSTEM (MCPS), SMALL
NSN 8340-01-323-2454
NSN 8340-01-334-7529
NSN 8340-01-528-4188
NSN 8340-01-528-8210**

PART NUMBER INDEX

PART NUMBER	FIG.	ITEM	PART NUMBER	FIG.	ITEM
AD86BS	16	2	MIL-W-43668 TYIII	BULK	38
C-0720-055-0620S	1	16	MIL-W-43668 TYIII	BULK	40
C-0720-055-0620S	1	38	MIL-W-530 TYIIA, CLASS 4	BULK	31
CMC-7971	18	3		BULK	32
F131-502SK	18	1	MS35307-367	1	35
LP378TYI	BULK	14		1	13
LS125	BULK	16	MS35338-139	17	3
MIL-C-43774	BULK	3	MS35492-27	17	5
MIL-C-5651	BULK	4	MS35492-78	16	10
MIL-F-21840TYII	BULK	5	MS35494-32	17	10
	BULK	6	MS51859-6	16	7
	BULK	7	MS51859-7	16	3
	BULK	8	M45913/1-4CS3	16	6
	BULK	9		1	34
	BULK	10		1	12
	BULK	11	MS51957-79	17	2
MIL-L-1709 TYXXVI	BULK	13	MS51959-61	17	8
MIL-PRF-44103	BULK	1	MS51975-15	16	8
	BULK	2	V-T-285TYI, CLASS 1,		
MIL-R-30500	BULK	15	SUBCLASS B	BULK	25
MIL-T-43566TYI, CLASS 4	BULK	19		BULK	26
	BULK	20		BULK	27
	BULK	21		BULK	28
	BULK	22	2326-N-253	17	7
	BULK	23	23B28045-1	6	3
	BULK	24	342-0100-00	17	6
	BULK	34	350-020-102	1	7
MIL-T-5038 TYII, CLASS 2	BULK	17		1	9
	BULK	18		1	24
	BULK	35		1	27
	BULK	36		1	32
	BULK	37	5-10-47	BULK	12
	BULK	39	5-13-4661	16	1
	BULK	41	5-13-4662-1	16	9
	BULK	42	5-13-4664-1	16	12
MIL-W-4088 TYVIII, CLASS 2	BULK	33	5-13-4668-1	16	4
	BULK	34	5-13-4668-2	16	5
	BULK	43	5-13-4671-1	16	11
MIL-W-4088 TYVIII B, CLASS 2	BULK	29	5-4-6344-1	2	1
	BULK	30	5-4-6344-2	2	1
MIL-W-4088 TYXX, CLASS 2	BULK	44	5-4-6345-1	3	1
	BULK	45	5-4-6345-2	3	1

PART NUMBER	FIG.	ITEM	PART NUMBER	FIG.	ITEM
5-4-6347-1	5	1	5-4-6976	1	17
5-4-6347-2	5	1	5-4-6980	1	2
5-4-6353	9	1	5-4-7457	17	1
5-4-6354	10	1	5-4-7458	17	4
5-4-6355	8	1	5-4-7459	17	12
5-4-6356-1	7	1	5-4-7460	17	13
5-4-6356-2	7	1	5-4-7461	17	14
5-4-6944	1	11	5-4-7462	17	15
5-4-6946	1	21	5-4-7465	17	18
5-4-6947	1	1	5-4-7467	17	16
5-4-6948	1	4	5-4-7468	17	11
	1	22	5-4-7469	17	9
5-4-6950	1	8	5-4-7474-1	19	1
	1	29	5-4-7474-2	19	1
5-4-6953	1	30	5-4-7476-1	20	1
5-4-6954	1	14	5-4-7476-2	20	1
	1	36	5-4-7478-1	6	1
5-4-6955	1	15	5-4-7478-1-16	6	2
	1	37	5-4-7478-2	6	1
5-4-6956	1	18	5-4-8487-1	21	1
	1	31	5-4-8487-2	21	1
5-4-6957	1	6	5-4-8496	17	17
	1	10	5-4-8745	18	2
	1	25	5-4-9061	13	1
	1	28	5-4-9062-1	13	2
	1	33	5-4-9063-1	13	3
5-4-6960	1	39	5-4-9065-1	12	1
	1	19	5-4-9067-1	14	1
5-4-6965	1	23	5-4-9068-1	15	1
5-4-6966	1	26	5-4-9686-1	1	41
5-4-6967	1	3	5-4-9691-1	4	1
5-4-6967-17	1	40	5-4-9691-2	4	1
5-4-6967-17	1	20	5-4-9692-1	11	1
5-4-6968	1	5	6931056	1	42

END OF WORK PACKAGE

CHAPTER 10
SUPPORTING INFORMATION
FOR
MODULAR COMMAND POST SYSTEM (MCPS), SMALL

**OPERATOR, UNIT, AND DIRECT SUPPORT MAINTENANCE
MODULAR COMMAND POST SYSTEM (MCPS), SMALL
REFERENCES**

SCOPE

This work package lists all field manuals, forms, technical manuals, and miscellaneous publications referenced in this manual.

FIELD MANUALS

FM 3-3	Decontamination Procedures
FM 3-5	NBC Decontamination
FM 3-11.4	Multiservice Tactics, Techniques, and Procedures for Nuclear, Biological and Chemical (NBC) Protection
FM 4-25.11	First Aid for Soldiers
FM 10-16	General Fabric Repair
FM 31-70	Basic Cold Weather Manual
FM 38-701	Preservation, Packaging and Packing of Military Supplies and Equipment

FORMS

DD Form 6	Packaging Improvement Report
DA Form 2404	Equipment Inspection and Maintenance Worksheet
DA Form 2028-2	Recommended changes to Equipment Technical Publications
SF 361	Discrepancy in Shipment Report
SF 362	Report of Packaging and Handling Deficiencies
SF 368	Quality Deficiency Report

TECHNICAL MANUALS

TM 5-1080-200-13&P	Camouflage Screen and Screen Support Systems
TM 750-244-3	Destruction of Army Material to prevent Enemy Use

DA PAMPHLETS

DA PAM 750-8	The Army Maintenance Management System (TAMMS) Users Manual
DA PAM 25-30	Modification Work Orders

FEDERAL STANDARDS

595	Colors
751	Stitches, Seams and Stitchings

MILITARY STANDARDS

147	Palletizing Unit Loads
704	Treatment and Painting of Material
731	Quality of Wood Members for Containers and Pallets

MISCELLANEOUS

TC 9-450	Metal Body Repair and Related Operations
----------	--

END OF WORK PACKAGE

**OPERATOR, UNIT AND DIRECT SUPPORT MAINTENANCE
MODULAR COMMAND POST SYSTEM (MCPS), SMALL
MAINTENANCE ALLOCATION CHART (MAC) INTRODUCTION**

**MAINTENANCE ALLOCATION CHART (MAC)
INTRODUCTION**

The Army Maintenance System MAC

This introduction provides a general explanation of all maintenance and repair functions authorized at the two maintenance levels under the Two-Level Maintenance System concept.

This MAC (immediately following the introduction) designates overall authority and responsibility for the performance of maintenance functions on the identified end item or component. The application of the maintenance functions to the end item or component levels, which are shown on the MAC in column (4) as:

Field – includes two columns, Unit maintenance and Direct Support maintenance. The Unit maintenance column is divided again into two more subcolumns, C for Operator or Crew and O for Unit maintenance.

Sustainment – includes two subcolumns, general support (H) and depot (D).

The tools and test equipment requirements (immediately following the MAC) list the tools and test equipment (both special tools and common tool sets) required for each maintenance function as referenced from the MAC.

The remarks (immediately following the tools and test equipment requirements) contain supplemental instructions and explanatory notes for a particular maintenance function.

Maintenance Functions

Maintenance functions are limited to and defined as follows:

1. Inspect. To determine the serviceability of an item by comparing its physical, mechanical, and/or electrical characteristics with established standards through examination (e.g., by sight, sound, or feel). This includes scheduled inspection and gagings and evaluation of cannon tubes.
2. Test. To verify serviceability by measuring the mechanical, pneumatic, hydraulic, or electrical characteristics of an item and comparing those characteristics with prescribed standards on a scheduled basis, i.e., load testing of lift devices and hydrostatic testing of pressure hoses.
3. Service. Operations required periodically To keep an item in proper operating condition; e.g., to clean (includes decontaminate, when required), to preserve, to drain, to paint, or to replenish fuel, lubricants, chemical fluids, or gases. This includes scheduled exercising and purging of recoil mechanisms. The following are examples of service functions:
 - a. Unpack. To remove from packing box for service or when required for the performance of maintenance operations.
 - b. Repack. To return item to packing box after service and other maintenance operations.
 - c. Clean. To rid the item of contamination.
 - d. Touch up. To spot paint scratched or blistered surfaces.
 - e. Mark. To restore obliterated identification.

4. **Adjust.** To maintain or regulate, within prescribed limits, by bringing into proper position, or by setting the operating characteristics to specified parameters.
5. **Align.** To adjust specified variable elements of an item to bring about optimum or desired performance.
6. **Calibrate.** To determine and cause corrections to be made or to be adjusted on instruments of test, measuring, and diagnostic equipment used in precision measurement. Consists of comparisons of two instruments, one of which is a certified standard of known accuracy, to detect and adjust any discrepancy in the accuracy of the instrument being compared.
7. **Remove/install.** To remove and install the same item when required to perform service or other maintenance functions. Install may be the act of emplacing, seating, or fixing into position a spare, repair part, or module (component or assembly) in a manner to allow the proper functioning of an equipment or system.
8. **Paint.** To prepare and spray color coats of paint so that the ammunition can be identified and protected. The color indicating primary use is applied, preferably, to the entire exterior surface as the background color of the item. Other markings are to be repainted as original so as to retain proper ammunition identification.
9. **Replace.** To remove an unserviceable item and install a serviceable counterpart in its place "Replace" is authorized by the MAC and assigned maintenance level is shown as the third position code of the Source, Maintenance and Recoverability (SMR) code.
10. **Repair.** The application of maintenance services, including fault location/troubleshooting, removal/installation, disassembly/assembly procedures and maintenance actions to identify troubles and restore serviceability to an item by correcting specific damage, fault, malfunction, or failure in a part, subassembly, module (component or assembly), end item, or system.

NOTE

The following definitions are applicable to the "repair" maintenance function: Services. Inspect, test, service, adjust, align, calibrate, and/or replace.

Fault location/troubleshooting. The process of investigating and detecting the cause of equipment malfunctioning; the act of isolating a fault within a system or Unit Under Test (UUT).

Disassembly/assembly. The step-by-step breakdown (taking apart) of a spare/functional group coded item to the level of its least component, that is assigned an SMR code for the level of maintenance under consideration (i.e., identified as maintenance significant).

Actions. Welding, grinding, riveting, straightening, facing, machining, and/or resurfacing.

11. **Overhaul.** That maintenance effort (service/action) prescribed to restore an item to a completely serviceable/operational condition as required by maintenance standards in appropriate technical publications. Overhaul is normally the highest degree of maintenance performed by the Army. Overhaul does not normally return an item to like new condition.
12. **Rebuild.** Consists of those services/actions necessary for the restoration of unserviceable equipment to a like new condition in accordance with original manufacturing standards. Rebuild is the highest degree of material maintenance applied to Army equipment. The rebuild operation includes the act of returning to zero those age measurements (e.g., hours/miles) considered in classifying Army equipment/components.

Explanation of Columns in the MAC

Column (1) Group Number. Column (1) lists Functional Group Codes (FGC) numbers, the purpose of which is to identify maintenance significant components, assemblies, subassemblies, and modules with the Next Higher Assembly (NHA).

Column (2) Component/Assembly. Column (2) contains the item names of components, assemblies, subassemblies, and modules for which maintenance is authorized.

Column (3) Maintenance Function. Column (3) lists the functions to be performed on the item listed in column (2). (For a detailed explanation of these functions refer to "Maintenance Functions" outlined above).

Column (4) Maintenance Level. Column (4) specifies each level of maintenance authorized to perform each function listed in column (3), by indicating work time required (expressed as manhours in whole hours or decimals) in the appropriate subcolumn. This work time figure represents the active time required to perform that maintenance function at the indicated level of maintenance. If the number or complexity of the tasks within the listed maintenance function varies at different maintenance levels, appropriate work time figures are to be shown for each level. The work time figure represents the average time required to restore an item (assembly, subassembly, component, module, end item, or system) to a serviceable condition under typical field operating conditions. This time includes preparation time (including any necessary disassembly/assembly time), troubleshooting/fault location time, and quality assurance time in addition to the time required to perform the specific tasks identified for the maintenance functions authorized in the MAC. The symbol designations for the various maintenance levels are as follows:

Field:

C Operator or Crew maintenance

O Unit maintenance

F Direct Support maintenance

Sustainment:

L Specialized Repair Activity

H General Support maintenance

D Depot maintenance

NOTE

The "L" maintenance level is not included in column (4) of the MAC. Functions to this level of maintenance are identified by work time figure in the "H" column of column (4), and an associated reference code is used in the REMARKS column (6). This code is keyed to the remarks and the SRA complete repair application is explained there.

Column (5) Tools and Equipment Reference Code. Column (5) specifies, by code, those common tool sets (not individual tools), common Test, Measurement and Diagnostic Equipment (TMDE), and special tools, special TMDE and special support equipment required to perform the designated function. Codes are keyed to the entries in the tools and test equipment table.

Column (6) Remarks Code. When applicable, this column contains a letter code, in alphabetical order, which is keyed to the remarks table entries.

Explanation of Columns in the Tools and Test Equipment Requirements

Column (1) – Tool or Test Equipment Reference Code. The tool or test equipment reference code correlates with a code used in Column (5) of the MAC.

Column (2) – Maintenance Level. The lowest level of maintenance authorized to use the tool or test equipment.

Column (3) – Nomenclature. Name or identification of the tool or test equipment.

Column (4) – National Stock Number (NSN). The NSN of the tool or test equipment.

Column (5) – Tool Number. The manufacturer's part number.

Explanation of Columns in the Remarks

Column (1) – Remarks Code. The code recorded in column (6) of the MAC.

Column (2) – Remarks. This column lists information pertinent to the maintenance function being performed as indicated in the MAC.

END OF WORK PACKAGE

**OPERATOR, UNIT, AND DIRECT SUPPORT MAINTENANCE
MODULAR COMMMAND POST SYSTEM (MCPS), SMALL
MAINTENANCE ALLOCATION CHART (MAC)**

Table 1. Maintenance Allocation Chart for Modular Command Post System.

(1) GROUP NUMBER	(2) COMPONENT/ ASSEMBLY	(3) MAINTENANCE FUNCTION	(4) MAINTENANCE LEVEL				(5) TOOLS AND EQUIPMENT REFERENCE CODE	(6) REMARKS CODE	
			FIELD		SUSTAINMENT				
			UNIT		DIRECT SUPPORT	GENERAL SUPPORT			DEPOT
			C	O	F	H			D
00	MODULAR COMMAND POST SYSTEM								
01	FRAME ASSEMBLY	Inspect Service Replace Repair	0.4 0.4	0.4 0.5 0.5			2, 3, 5, 7		
0101	TENT FRAME BRACKET	Inspect Replace	0.1 0.1				A		
02	TENT FABRIC ASSEMBLIES	Inspect Service	0.5 1.2						
0201	PLAIN WALL ASSEMBLY	Replace Repair	0.5 0.5	0.5			1, 4, 6 B		
0202	WINDOW WALL ASSEMBLY	Replace Repair	0.5 0.5	0.5			1, 4, 6 B, C		
0203	HORIZONTAL ECU/WINDOW WALL ASSEMBLY	Replace Repair	0.5 0.5	0.5			1, 4, 6 A B		
0204	ENTRANCE WAY ASSEMBLY	Replace Repair	0.5 0.5	0.5			1, 4, 6 B		
0205	ROOF CAP ASSEMBLY	Replace Repair	0.5 0.5	0.5			1, 4, 6 B		
0206	RAIN GUTTER ASSEMBLY	Replace Repair	0.5 0.5	0.5			1, 4, 6 B		
0207	FLOOR ASSEMBLY	Replace Repair	0.5 0.5	0.5			1, 4, 6 B		
0208	PLAIN WALL LINER	Replace Repair	0.5 0.5	0.5			1, 4, 6 B, C		

Table 1. Maintenance Allocation Chart for Modular Command Post System – Continued.

(1) GROUP NUMBER	(2) COMPONENT/ ASSEMBLY	(3) MAINTENANCE FUNCTION	(4) MAINTENANCE LEVEL				(5) TOOLS AND EQUIPMENT REFERENCE CODE	(6) REMARKS CODE	
			FIELD		SUSTAINMENT				
			UNIT		DIRECT SUPPORT	GENERAL SUPPORT			DEPOT
			C	O	F	H			D
0209	ENTRANCE WAY/WINDOW WALL LINER	Replace	0.5					1, 4, 6	B, C
		Repair	0.5		0.5				
03	INSULATED LINERS	Inspect	0.1						A, B
		Service	1.0						
0301	INSULATED LINER, ECU / WINDOW WALL	Replace	0.5					1, 4, 6	A, B
		Repair	0.5		0.5				
0302	INSULATED LINER, ENTRANCE WAY	Replace	0.5					1, 4, 6	A, B
		Repair	0.5		0.5				
0303	INSULATED LINER, BOOT WALL ASSEMBLY	Replace	0.5					1, 4, 6	A, B
		Repair	0.5		0.5				
0304	INSULATED LINER, ROOF CAP ASSEMBLY	Replace	0.5					1, 4, 6	A, B
		Repair	0.5		0.5				
0305	INSULATED LINER, RAIN GUTTER ASSEMBLY	Replace	0.5					1, 4, 6	A, B
		Repair	0.5		0.5				
04	TABLE, FIELD, FOLDING LEGS, METAL	Inspect	0.2	0.2				2, 3, 5, 7	
		Service	0.3						
		Replace		0.5					
		Repair		0.5					
05	COMPLEXING MAP BOARD	Inspect	0.2	0.2				2, 3, 5, 7	C
		Service	0.3						
		Replace		0.1					
		Repair		0.5					
06	LIGHT ASSEMBLY	Inspect	0.5					2, 3, 5, 7	
		Service	0.4						
		Test		0.1					
		Replace	0.2						
		Repair		1.0					

Table 1. Maintenance Allocation Chart for Modular Command Post System – Continued.

(1) GROUP NUMBER	(2) COMPONENT/ ASSEMBLY	(3) MAINTENANCE FUNCTION	(4) MAINTENANCE LEVEL					(5) TOOLS AND EQUIPMENT REFERENCE CODE	(6) REMARKS CODE	
			FIELD		SUSTAINMENT					
			UNIT		DIRECT SUPPORT	GENERAL SUPPORT	DEPOT			
			C	O	F	H	D			
07	TRANSPORT BAG ASSEMBLY – FRAME	Replace	0.1					1, 4, 6	B	
		Repair	0.5		0.5					
08	TRANSPORT BAG ASSEMBLY – FABRIC	Replace	0.1					1, 4, 6	B	
		Repair	0.5		0.5					
09	VESTIBULE/PIN CONTAINER	Replace	0.1					1, 4, 6	B	
		Repair	0.5		0.5					

Table 2. Tools and Test Equipment for Modular Command Post System.

(1) TOOLS OR TEST EQUIPMENT REFERENCE CODE	(2) MAINTENANCE LEVEL	(3) NOMENCLATURE	(4) NATIONAL STOCK NUMBER	(5) TOOL NUMBER
1	C	Brush, Scrub	7920-00-240-7174	
2	O	Drill, Electric, Portable	5130-00-935-7354	
3	O	Drill Set, Twist	5133-00-293-0983	
4	O	Repair Kit, Tentage	8340-00-262-5767	
5	O	Riveting Tool	5180-01-201-4978	
6	F	Sewing Machine, Industrial	3530-00-892-4631	
7	O	Tool Kit, General Mechanic's	5180-00-177-7033	

Table 3. Remarks for Modular Command Post System.

(1) REMARK CODES	(2) REMARKS
A	Type III only.
B	Repair of fabric at Field Maintenance level is limited to the capability of the tentage repair kit. Repairs should be sent to Direct Support for machine stitching whenever possible.
C	Type I only.

END OF WORK PACKAGE

**OPERATOR, UNIT, AND DIRECT SUPPORT MAINTENANCE
MODULAR COMMMAND POST SYSTEM (MCPS), SMALL
COMPONENTS OF END ITEM (COEI) AND BASIC ISSUE ITEMS (BII) LISTS**

COMPONENTS OF END ITEM (COEI) AND BASIC ISSUE ITEMS (BII) LISTS

INTRODUCTION

Scope

This work package lists COEI and BII for the Modular Command Post System (MCPS), Small to help you inventory items for safe and efficient operation of the equipment.

General

The COEI and BII information is divided into the following lists:

Components of End Item (COEI). This list is for information purposes only and is not authority to requisition replacements. These items are part of the Modular Command Post System (MCPS). As part of the end item, these items must be with the end item whenever it is issued or transferred between property accounts. Items of COEI are removed and separately packaged for transportation or shipment only when necessary. Illustrations are furnished to help you find and identify the items.

Basic Issue Items (BII). These essential items are required to place the Modular Command Post System (MCPS) in operation, operate it, and to do emergency repairs. Although shipped separately packaged, BII must be with the Modular Command Post System (MCPS) during operation and when it is transferred between property accounts. Listing these items is your authority to request/requisition them for replacement based on authorization of the end item by the TOE/MTOE. Illustrations are furnished to help you find and identify the items.

Explanation of Columns in the COEI List and BII List

Column (1) Item Number. Gives you the reference number of the item listed.

Column (2) National Stock Number (NSN) and Illustration. Identifies the stock number of the item to be used for requisitioning purposes and provides an illustration of the item.

Column (3) Description, Part Number/(CAGEC). Identifies the Federal item name (in all capital letters) followed by a minimum description when needed. The stowage location of COEI and BII is also included in this column. The last line below the description is the part number and the Commercial and Government Entity Code (CAGEC) (in parentheses).

Column (4) Usable On Code. When applicable, gives you a code if the item you need is not the same for different models of equipment. These codes are identified below:

<u>Code</u>	<u>Used on</u>
EWG	MCPS Type I, Green
EZN	MCPS Type I, Tan
FUD	MCPS Type III, Green
FUE	MCPS Type III, Tan

Column (5) U/I. Unit of Issue (U/I) indicates the physical measurement or count of the item as issued per the National Stock Number shown in column (2).

Column (6) Qty Rqr. Indicates the quantity required.

Table 1. Components of End Item (COEI).

(1) Item Number	(2) National Stock Number (NSN) and Illustration	(3) Description, Part Number/(CAGEC)	(4) Usable On Code	(5) U/I	(6) Qty Rqr
1	8340-01-334-2341 	FRAME ASSEMBLY 5-4-6947 (81337)		EA	1
2	8340-01-524-8052 	BRACKET, TENT FRAME 5-4-9686 (81337)	FUD, FUE	EA	6
3	8340-01-333-4718 	PLAIN WALL ASSEMBLY, CAMOUFLAGE GREEN 5-4-6344-1 (81337)	EWG, FUD	EA	1
4	8340-01-337-5297 	PLAIN WALL ASSEMBLY, DESERT TAN 5-4-6344-2 (81337)	EZN, FUE	EA	1
5	8340-01-331-0152 	WINDOW WALL ASSEMBLY, CAMOUFLAGE GREEN 5-4-6345-1 (81337)	EWG	EA	2

Table 1. Components of End Item (COEI) - Continued.

(1) Item Number	(2) National Stock Number (NSN) and Illustration	(3) Description, Part Number/(CAGEC)	(4) Usable On Code	(5) U/I	(6) Qty Rqr
6	8340-01-337-5298 	WINDOW WALL ASSEMBLY, DESERT TAN 5-4-6345-2 (81337)	EZN	EA	2
7	8340-01-529-0590 	HORIZONTAL ECU/WINDOW WALL ASSEMBLY, CAMOUFLAGE GREEN 5-4-9691-1 (81337)	FUD	EA	2
8	8340-01-529-0596 	HORIZONTAL ECU/WINDOW WALL ASSEMBLY, DESERT TAN 5-4-9691-2 (81337)	FUE	EA	2
9	8340-01-331-3302 	ENTRANCE, SHELTER, CAMOUFLAGE GREEN 5-4-6347-1 (81337)	EWG, FUD	EA	1
10	8340-01-337-5299 	ENTRANCE, SHELTER, DESERT TAN 5-4-6347-2 (81337)	EZN, FUE	EA	1

Table 1. Components of End Item (COEI) - Continued.

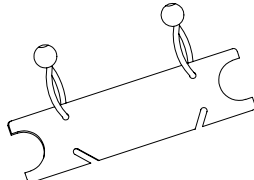
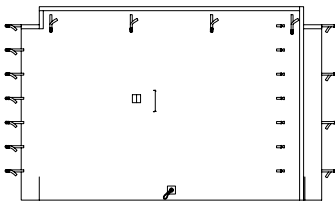
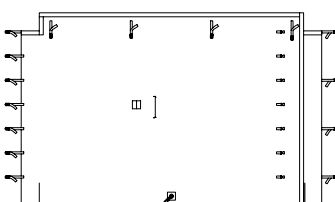
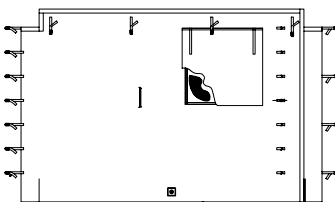

(1) Item Number	(2) National Stock Number (NSN) and Illustration	(3) Description, Part Number/(CAGEC)	(4) Usable On Code	(5) U/I	(6) Qty Rqr
11	8340-01-331-5422 	ROOF CAP ASSEMBLY, CAMOUFLAGE GREEN 5-4-7478-1 (81337)	EWG, FUD	EA	1
12	8340-01-337-5300 	ROOF CAP ASSEMBLY, DESERT TAN 5-4-7478-2 (81337)	EZN, FUE	EA	1
13	8340-01-331-0153 	GUTTER, RAIN, CAMOUFLAGE GREEN 5-4-6356-1 (81337)	EWG, FUD	EA	1
14	8340-01-337-5699 	GUTTER, RAIN, DESERT TAN 5-4-6356-2 (81337)	EZN, FUE	EA	1
15	8340-01-331-3304 	FLOOR ASSEMBLY 5-4-6355 (81337)		EA	1
16	5410-01-333-0661 	PLAIN WALL LINER 5-4-6353 (81337)	EWG, EZN	EA	1
17	5410-01-331-3303 	LINER, ENTRANCE WALL 5-4-6354 (81337)	EWG, EZN	EA	3

Table 1. Components of End Item (COEI) - Continued.

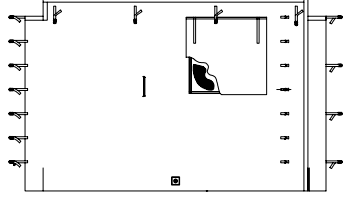
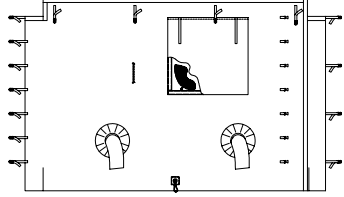
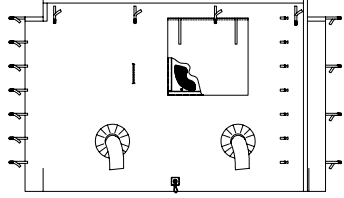
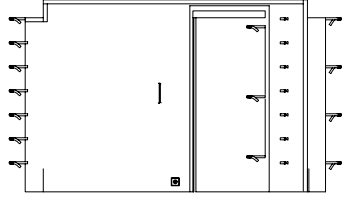
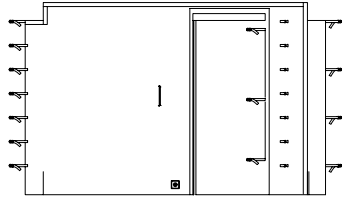
(1) Item Number	(2) National Stock Number (NSN) and Illustration	(3) Description, Part Number/(CAGEC)	(4) Usable On Code	(5) U/I	(6) Qty Rqr
18	8340-01-529-6215 	INSULATED LINER, ECU/WINDOW WALL 5-4-9692-1 (81337)	FUD, FUE	EA	2
19	8340-01-524-8009 	LINER, INSULATED, EXTERIOR WALL 5-4-9065-1 (81337)	FUD, FUE	EA	1
20	8340-01-524-8042 	INSULATED LINER, BOOT WALL ASSEMBLY 5-4-9061 (81337)	FUD, FUE	EA	1
21	8340-01-524-8038 	LINER, INSULATED, ROOF CAP 5-4-9067-1 (81337)	FUD, FUE	EA	1
22	8340-01-524-8037 	LINER, INSULATED, RAIN GUTTER 5-4-9068-1 (81337)	FUD, FUE	EA	1
23	8340-01-327-7685 	TABLE, FOLDING, TENT 5-13-4661 (81337)		EA	2

Table 1. Components of End Item (COEI) - Continued.

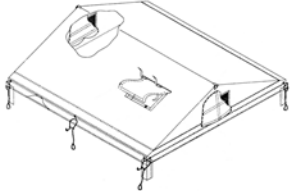
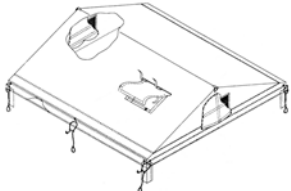
(1) Item Number	(2) National Stock Number (NSN) and Illustration	(3) Description, Part Number/(CAGEC)	(4) Usable On Code	(5) U/I	(6) Qty Rqr
24	6230-01-465-8931 	LIGHT SET, GENERAL ILLUMINATION CMC0019-LS (80515)	EWG, EZN	EA	1
25	8340-01-327-6124 	MAPBOARD 5-4-7457 (81337)		EA	4
26	8340-01-337-5561 	TRANSPORT BAG ASSEMBLY – FRAME, CAMOUFLAGE GREEN 5-4-7474-1 (81337)	EWG, FUD	EA	1
27	8340-01-336-9093 	TRANSPORT BAG ASSEMBLY – FRAME, DESERT TAN 5-4-7474-2 (81337)	EZN, FUE	EA	1
28	8340-01-337-7234 	TRANSPORT BAG ASSEMBLY – FABRIC, CAMOUFLAGE GREEN 5-4-7476-1 (81337)	EWG, FUD	EA	5
29	8340-01-337-9215 	TRANSPORT BAG ASSEMBLY – FABRIC, DESERT TAN 5-4-7476-2 (81337)	EZN, FUE	EA	5

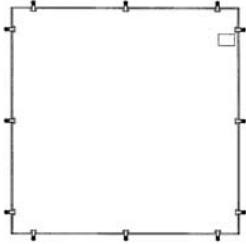
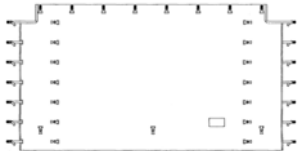
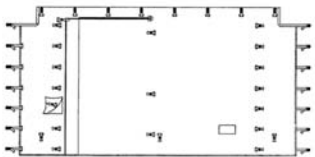
Table 1. Components of End Item (COEI) - Continued.

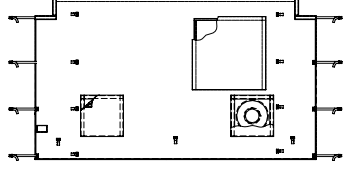
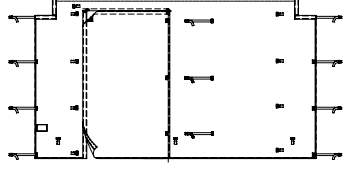
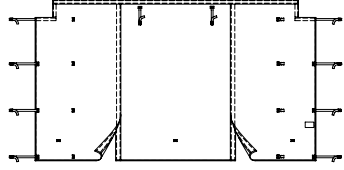
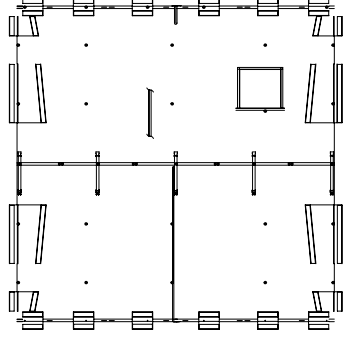
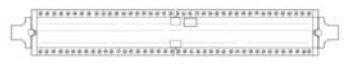
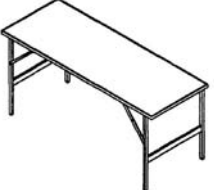

(1) Item Number	(2) National Stock Number (NSN) and Illustration	(3) Description, Part Number/(CAGEC)	(4) Usable On Code	(5) U/I	(6) Qty Rqr
30	8340-00-823-7451 	TENT PIN, STEEL MIL-P-501 (81337)		EA	8
31	8340-00-261-9751 	TENT STAKE, WOOD MIL-P-2383 (81337)		EA	8
32	8340-01-186-3030 	VESTIBULE/PIN CONTAINER CAMOUFLAGE GREEN 5-4-8487-1 (81337)	EWG, FUD	EA	1
33	8340-01-440-8886 	VESTIBULE/PIN CONTAINER DESERT TAN 5-4-8487-2 (81337)	EZN, FUE	EA	1
34	5340-01-336-7034 	SUPPORT STRAP 5-4-5531 (81337)		EA	10

Table 1. Components of End Item (COEI) - Continued.

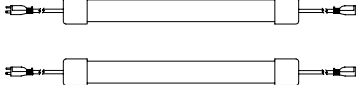
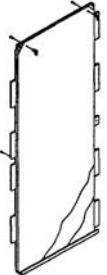
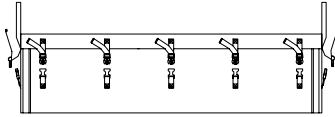
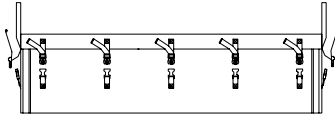
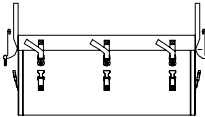
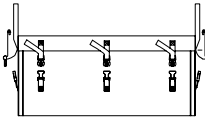

(1) Item Number	(2) National Stock Number (NSN) and Illustration	(3) Description, Part Number/(CAGEC)	(4) Usable On Code	(5) U/I	(6) Qty Rqr
35		CORD, EXTENSION, 50-FT 02308-88-03 (1QYY2)	EWG, FUD	EA	1
36		POWER STRIP, 6 OUTLET 5H213 (1RDQ0)	FUD, FUE	EA	1

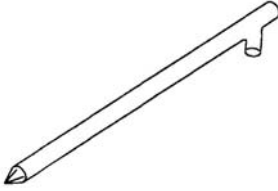
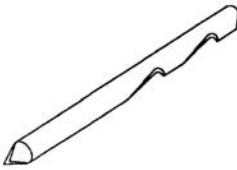
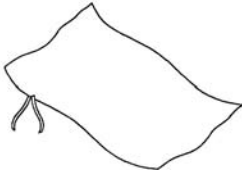
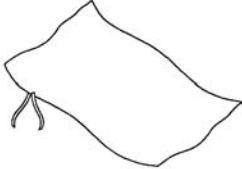
Table 2. Basic Issue Items (BII).

(1) Item Number	(2) National Stock Number (NSN) and Illustration	(3) Description, Part Number/(CAGEC)	(4) Usable On Code	(5) U/I	(6) Qty Rqr
1		TM 10-8340-243-13&P		EA	1

END OF WORK PACKAGE

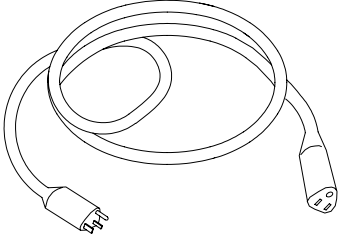
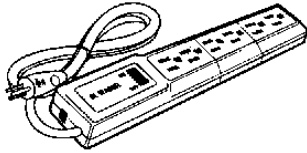
**OPERATOR, UNIT, AND DIRECT SUPPORT MAINTENANCE
MODULAR COMMAND POST SYSTEM (MCPS), SMALL
ADDITIONAL AUTHORIZATION LIST (AAL)**

INTRODUCTION**Scope**

This work package lists additional items you are authorized for the support of the Modular Command Post System (MCPS), Small.

General

This list identifies items that do not have to accompany the Modular Command Post System (MCPS), Small and that do not have to be turned in with it. These items are all authorized to you by CTA, MTOE, TDA, or JTA.

Explanation of Columns in the AAL

Column (1) National Stock Number (NSN). Identifies the stock number of the item to be used for requisitioning purposes.

Column (2) Description, Part Number/(CAGEC). Identifies the Federal item name (in all capital letters) followed by a minimum description when needed. The last line below the description is the part number and the Commercial and Government Entity Code (CAGEC) (in parentheses).

Column (3) Usable On Code. When applicable, gives you a code if the item you need is not the same for different models of equipment. These codes are identified below:

<u>Code</u>	<u>Used on</u>
EWG	MCPS Type I, Green
EZN	MCPS Type I, Tan
FUD	MCPS Type III, Green
FUE	MCPS Type III, Tan

Column (4) U/I. Unit of Issue (U/I) indicates the physical measurement or count of the item as issued per the National Stock Number shown in column (1).

Column (5) Qty Recm. Indicates the quantity recommended.

Table 1. Additional Authorization List (AAL).

(1) National Stock Number (NSN)	(2) Description, Part Number/(CAGEC)	(3) Usable On Code	(4) U/I	(5) Qty Recm
4120-01-449-0459	AIR CONDITIONER, FDECU 9454100 (94833)		EA	1
8340-01-524-7934	ASSEMBLY, ECU WINDOW WALL, MCPS 5-4-9071-1 (81337)		EA	1
5410-01-378-8301	BOOTWALL, MODULAR COMMAND POST TYPE I, CLASS 1 FOR M577, GREEN 5-4-7484-1 (81337)	EWG, FUD	EA	1
5410-01-380-2241	BOOTWALL, MODULAR COMMAND POST TYPE I, CLASS 2 FOR M577, TAN 5-4-7484-2 (81337)	EZN, FUE	EA	1
5410-01-364-4497	BOOTWALL, TENT TYPE II, CLASS 1 FOR RWS, GREEN MIL-B-44418,TY2,CL1 (81349)	EWG, FUD	EA	1
	BOOTWALL, TENT TYPE II, CLASS 2 FOR RWS, TAN 5-4-8184-2(81337)	EZN, FUE	EA	1
5420-01-364-4496	BOOTWALL, TENT TYPE IV, CLASS 1 FOR S-250E, GREEN MIL-B-44418,TY4,CL1 (81349)	EWG, FUD	EA	1
	BOOTWALL, TENT TYPE IV, CLASS 2 FOR S-250E, TAN 5-4-8213-2 (81337)	EZN, FUE	EA	1
8340-01-524-7884	ECU WALL ASSEMBLY, MCPS, WITH 4 ECU DUCTS, GREEN 5-4-9070-1 (81337)		EA	1
8340-00-951-6423	GROUND ANCHOR KIT 4-1-197AND4-1-199 (81337)	EWG, FUD	EA	1
8340-01-450-5161	GUTTER, RAIN, TENT, 4-WAY 5-4-8609-GREEN (80515)	EWG, FUD	EA	1
8340-01-450-7156	GUTTER, RAIN, TENT, 4-WAY 5-4-8609-TAN (80515)	EZN, FUE	EA	1
4520-01-431-8927	HEATER, SPACE, CONVECTIVE SHC35 (81337)		EA	1
4520-01-329-3451	HEATER, SPACE 5-13-4400 (81337)		EA	1
8340-01-524-8034	LINER, INSULATED, ECU WALL ASSEMBLY, WITH 4 ECU DUCTS 5-4-9066-1 (81337)		EA	1
8340-01-524-7990	LINER, INSULATED, WINDOW WALL, WITH VERTICAL ECU DUCTS 5-4-9064-1 (81337)		EA	1
5120-00-926-7116	MALLET, WOOD LLL-M-71 (81348)		EA	1
8340-00-823-7451	PIN, TENT MIL-P-501 (81349)		EA	8
8340-00-262-5767	REPAIR KIT, TENTAGE MIL-DTL-3372 (81349)		EA	1

END OF WORK PACKAGE

**OPERATOR, UNIT, AND DIRECT SUPPORT MAINTENANCE
MODULAR COMMAND POST SYSTEM (MCPS), SMALL
EXPENDABLE AND DURABLE ITEMS LIST**

INTRODUCTION

Scope

This work package lists expendable and durable items that you will need to operate and maintain the Modular Command Post System (MCPS), Small. This list is for information only and is not authority to requisition the listed items. These items are authorized to you by CTA 50-970, Expendable/Durable Items (Except Medical, Class V Repair Parts, and Heraldic Items), CTA 50-909, Field and Garrison Furnishings and Equipment or CTA 8-100, Army Medical Department Expendable/Durable Items.

Explanation of Columns in the Expendable/Durable Items List

Column (1) Item No. This number is assigned to the entry in the list and is referenced in the narrative instructions to identify the item (e.g., Use brake fluid (WP 0098, item 5)).

Column (2) Level. This column identifies the lowest level of maintenance that requires the listed item
C = Operator/Crew, O = Unit, F = Direct Support.

Column (3) National Stock Number (NSN). This is the NSN assigned to the item which you can use to requisition it.

Column (4) Item Name, Description, Part Number/(CAGEC). This column provides the other information you need to identify the item. The last line below the description is the part number and the Commercial and Government Entity Code (CAGEC) (in parentheses).

Column (5) U/I. Unit of Issue (U/I) code shows the physical measurement or count of an item, such as gallon, dozen, gross, etc.

Table 1. Expendable and Durable Items List.

(1) Item No.	(2) Level	(3) National Stock Number (NSN)	(4) Item Name, Description, Part Number/ (CAGEC)	(5) U/I
1	C	8020-00-597-4761	BRUSH, PAINT H-B-420 (81349)	EA
2	C	7920-00-240-7174	BRUSH, SCRUB HB1490-5 (81348)	EA
3	C	6545-00-656-1093	FIRST AID KIT, GENERAL 6170-008 (04024)	EA
4	C	8415-00-753-6551	GLOVES, TOXICOLOGIAL PROTECTIVE, LARGE (81349) MIL-G-12223	PR
5	C	8415-00-753-6552	GLOVES, TOXICOLOGIAL PROTECTIVE, MEDIUM (81349) MIL-G-12223	PR
6	C	8415-00-753-6553	GLOVES, TOXICOLOGIAL PROTECTIVE, SMALL (81349) MIL-G-12223	PR
7	O	5970-00-815-1295	HEAT SHRINK, ¼ IN 7230941-P56 (03538)	FT
8	O	7690-00-689-5212	MARKER,IDENTIFICATION, WIRE TCWM NO. 16 (59493)	EA
9	C	7920-00-205-1711	RAGS, WIPING (58536) A-A-2522	LB
10	C	8030-01-350-4984	SEALING COMPOUND 83-234C (OR6N1)	GL
11	C	7930-00-965-4868	SOAP,LAUNDRY A-A-1375 (58536)	BX
12	O	5940-00-168-3382	SPLICE, CONDUCTOR , BUTT#14-16 – BLUE B231 (98410)	HD
13	O	5940-00-665-7317	SPLICE, CONDUCTOR , BUTT#18-22 1-34070-1 (00779)	HD
14	O	5315-00-999-1090	STAPLE K300159 (34623)	LB
15	O	5975-00-727-5153	STRAP,TIEDOWN,ELECTRICAL 26002060390 (0124B)	HD
16	O	5970-00-644-3167	TAPE, ELECTRICAL INSULATION, ¼ INCH WIDTH (58536) A-A-2094	RL
17	O	5940-00-143-4780	TERMINAL, LUG , #10 STUD 34161 (00779)	HD

END OF WORK PACKAGE

**OPERATOR, UNIT, AND DIRECT SUPPORT MAINTENANCE
MODULAR COMMAND POST SYSTEM (MCPS), SMALL
MANDATORY REPLACEMENT PARTS**

This work package includes a list of all mandatory replacement parts referenced in the task initial setups and procedures. These are items that must be replaced during maintenance whether they have failed or not. This includes items based on usage intervals such as miles, time, rounds, fired, etc.

Table 1. Mandatory Replacement Parts.

Item No.	Part Number/(CAGEC)	National Stock Number (NSN)	Nomenclature	Qty
The are no Mandatory Replacement Parts specified for the MCPS, Small.				

END OF WORK PACKAGE

<u>Subject</u>	INDEX	<u>WP Sequence No. – Page No.</u>
	0 - 9	
301 Lock Stitch.....		WP 0017-2
401 Chain Stitch.....		WP 0017-2
A		
AAL.....		WP 0048-2
Additional Authorization List (AAL)		WP 0048-2
Additional Authorization List (AAL) Introduction.....		WP 0048-1
Adhesive Patch Application.....		WP 0012-3
Anchoring the Roof Cap.....		WP 0005-11
Area.....		WP 0002-22
Army Material, Destruction Of To Prevent Enemy Use		WP 0001-2
Assemble the Rafters.....		WP 0005-3
B		
Basic Issue Items (BII)		WP 0047-9
BII		WP 0047-9
Biological Decontamination Procedures		WP 0006-3
Boot Wall Assembly Insulated Liner		WP 0002-15
Bootwalls		WP 0003-5
Buckles, Repair		WP 0012-7
Bulk Materials List.....		WP 0041-1
C		
Cable Assemblies, Replace		WP 0014-6
Capabilities		WP 0002-1
Care, Safety, And Handling.....		WP 0001-4
Cautions		WP 0001-4
Center Wall Frame Assembly		WP 0002-2
Chain Stitch, Type 401		WP 0017-2
Characteristics		WP 0002-1
Chemical Decontamination Procedures.....		WP 0006-3
COEI.....		WP 0047-2
Cold		WP 0006-1
Complexing		WP 0003-6
Complexing Map Board Repair Parts and Special Tools Lists (RPSTL)		WP 0035-2
Complexing the Tents		WP 0005-14
Components Of End Item (COEI)		WP 0047-2
Components Of End Item (COEI) and Basic Issue Items (BII) Introduction		WP 0047-1
Connecting the Frame Sections.....		WP 0005-4
Connecting Wall Sections (Type I Shown).....		WP 0005-17
Control, Corrosion (CPC).....		WP 0001-2
Controls, Frame		WP 0004-1
Controls, Light		WP 0004-2
Cord, Elastic, Fabrication.....		WP 0016-2
Corrosion Prevention And Control (CPC)		WP 0001-2
CPC.....		WP 0001-2

<u>Subject</u>	<u>WP Sequence No. – Page No.</u>
D	
Data, Equipment	WP 0002-22
Decontamination Procedures, Interim	WP 0006-3
Description and Use of Operator Controls and Indicators	WP 0004-1
Destruction Of Army Material To Prevent Enemy Use	WP 0001-2
Detent Assembly, Replace	WP 0014-5
Differences Between Models	WP 0002-21
Dimensions	WP 0002-22
Direct Support Maintenance, Tent Fabric Assemblies.....	WP 0017-1
Disconnect Power from the Lights	WP 0005-27
Doors, Operation.....	WP 0005-23
Dry Heat	WP 0006-1
DS2	WP 0006-3
Durable Items, Expendable and, List.....	WP 0049-2
Dust Storms	WP 0006-2
E	
ECU/Window Wall Insulated Liner	WP 0002-13
EIR	WP 0001-1
Elastic Cord Fabrication	WP 0016-2
End Wall Frame Assembly.....	WP 0002-2
Enemy Use, Destruction Of Army Material To Prevent	WP 0001-2
Entrance Way Assembly	WP 0002-7
Entrance Way Assembly Repair Parts and Special Tools Lists (RPSTL)	WP 0023-2
Entrance Way Insulated Liner	WP 0002-14
Entrance Way Set-Up	WP 0005-18
Entrance Way/Window Wall Liner.....	WP 0002-12
Entrance Way/Window Wall Liner Repair Parts and Special Tools Lists (RPSTL)	WP 0028-2
Equipment Characteristics, Capabilities And Features.....	WP 0002-1
Equipment Data	WP 0002-22
Equipment Description and Data	WP 0002-1
Equipment Improvement Recommendations (EIR)	WP 0001-1
Equipment Name	WP 0001-1
Equipment Straps and Mapboard	WP 0005-21
Equipment, Purpose Of	WP 0001-1
Expendable and Durable Items List.....	WP 0049-2
Expendable and Durable Items List Introduction	WP 0049-1
Extending the Frame to its Full Height.....	WP 0005-13
F	
Fabric Assemblies PMCS	WP 0010-4
Fabric Sections	WP 0003-2
Fabric Sections, Prepare for Movement	WP 0005-28
Fabric Transport Bag	WP 0002-20
Fabric Wall Assemblies Installation (Type I Shown).....	WP 0005-15
Fabric, Repair with Adhesive Patch Application	WP 0012-3
Fabric, Repair with Hand Stitched Patch Application	WP 0012-4
Fabric, Roof Cap	WP 0005-30
Feature, Special	WP 0001-1

Subject

WP Sequence No. – Page No.

F - continued

Features	WP 0002-1
Field Table Assembly.....	WP 0002-18
Field Table Not Steady.....	WP 0008-5
Flooding.....	WP 0006-1
Floor Assembly	WP 0002-10
Floor Assembly Repair Parts and Special Tools Lists (RPSTL)	WP 0026-2
Folding Table	WP 0005-22
Forms	WP 0001-1
Frame Assembly	WP 0003-1
Frame Assembly	WP 0002-3
Frame Assembly – Unit Maintenance	WP 0014-1
Frame Assembly PMCS.....	WP 0010-2
Frame Assembly Repair Parts and Special Tools Lists (RPSTL)	WP 0019-2
Frame Assembly Troubleshooting	WP 0008-1
Frame Controls	WP 0004-1
Frame Legs, Unfold.....	WP 0005-9
Frame Pieces, Unpack.....	WP 0005-2
Frame Sections, Connecting.....	WP 0005-4
Frame Sections, Prepare for Movement.....	WP 0005-32
Frame Transport Bag.....	WP 0002-20
Frame, Extending to its Full Height.....	WP 0005-13

G

General Information	WP 0001-1
Grommet, Replace	WP 0012-6
Gutter Assembly, Rain	WP 0002-9

H

Hand Stitched Patch Application.....	WP 0012-4
Hand Stitches.....	WP 0012-5
Handle, Repair	WP 0014-3
Handling	WP 0001-4
Heavy Rain.....	WP 0006-1
High Altitude.....	WP 0006-2
Horizontal ECU/Window Wall Assembly.....	WP 0002-6
How To Use This Manual.....	vi

I

Identification Labels	WP 0005-25
Index, National Stock Number	WP 0042-1
Index, Part Number	WP 0043-1
Index, Troubleshooting	WP 0007-1
Information, Warranty	WP 0001-2
Inspection.....	WP 0005-2
Install the Light Support Straps.....	WP 0005-5
Install the Roof Cap Liner.....	WP 0005-6
Installation, Fabric Wall Assemblies	WP 0005-15

Subject

WP Sequence No. – Page No.

I - continued

Installation, Light Set	WP 0005-12
Installation, Roof Cap	WP 0005-8
Installation, Wall Liner	WP 0005-20
Insulated Liner, Boot Wall Assembly Repair Parts and Special Tools Lists (RPSTL)	WP 0031-2
Insulated Liner, ECU / Window Wall Repair Parts and Special Tools Lists (RPSTL)	WP 0029-2
Insulated Liner, Entrance Way Repair Parts and Special Tools Lists (RPSTL)	WP 0030-2
Insulated Liner, Rain Gutter Assembly Repair Parts and Special Tools Lists (RPSTL)	WP 0033-2
Insulated Liner, Roof Cap Assembly Repair Parts and Special Tools Lists (RPSTL)	WP 0032-2
Interim Nuclear, Biological, And Chemical (NBC) Decontamination Procedures	WP 0006-3
Introduction, Additional Authorization List (AAL)	WP 0048-1
Introduction, Components Of End Item (COEI) and Basic Issue Items (BII)	WP 0047-1
Introduction, Expendable and Durable Items List	WP 0049-1
Introduction, Maintenance Allocation Chart (MAC)	WP 0045-1
Introduction, PMCS	WP 0009-1
Introduction, Repair Parts and Special Tools Lists (RPSTL)	WP 0018-1

L

Label, MCPS Setup	WP 0005-24
Labels, Identification	WP 0005-25
Lamp, Replace	WP 0013-1
Leg Assembly, Lower, Replace	WP 0014-4
Leg Assembly, Upper, Repair	WP 0014-1
Light Assembly	WP 0003-3
Light Assembly Repair Parts and Special Tools Lists (RPSTL)	WP 0036-2
Light Controls	WP 0004-2
Light Set	WP 0002-19
Light Set – Operator Maintenance	WP 0013-1
Light Set Installation	WP 0005-12
Light Set PMCS	WP 0010-8
Light Support Straps, Install	WP 0005-5
Lights, Disconnect Power	WP 0005-27
Liner, Entrance Way/Window Wall	WP 0002-12
Liner, Insulated, Boot Wall Assembly	WP 0002-15
Liner, Insulated, ECU/Window Wall	WP 0002-13
Liner, Insulated, Entrance Way	WP 0002-14
Liner, Insulated, Rain Gutter Assembly	WP 0002-17
Liner, Insulated, Roof Cap Assembly	WP 0002-16
Liner, Plain Wall	WP 0002-11
Liner, Roof Cap, Install	WP 0005-5
Liner, Roof Cap, Secure	WP 0005-6
Location And Description Of Major Components	WP 0002-2
Lock Stitch, Type 301	WP 0017-2

<u>Subject</u>	<u>WP Sequence No. – Page No.</u>
M	
MAC	WP 0046-1
Maintenance Allocation Chart (MAC).....	WP 0046-1
Maintenance Allocation Chart (MAC) Introduction.....	WP 0045-1
Maintenance Forms, Records And Reports.....	WP 0001-1
Major Components, Location And Description Of	WP 0002-2
Mandatory Replacement Parts	WP 0050-1
Manual, Type Of	WP 0001-1
Manufactured Items, Illustrated List of	WP 0016-1
Mapboard	WP 0002-18
Mapboard	WP 0005-21
Mapboard Assembly	WP 0002-18
Mapboard Assembly	WP 0003-4
Mapboard Assembly – Unit Maintenance	WP 0015-1
Mapboard Assembly, Repair	WP 0015-2
Mapboard PMCS.....	WP 0010-5
Mapboards, Prepare for Movement	WP 0005-26
Material, Quality Of	WP 0001-4
MCPS Setup Label on Frame Transport Bag	WP 0005-24
MCPS Will Not Stay Taut (Type I Shown)	WP 0008-3
Model Number And Equipment Name	WP 0001-1
Modular Command Post System (MCPS), Small (Type I Shown).....	WP 0005-1
Moist Heat	WP 0006-1
Mud	WP 0006-2
N	
National Stock Number Index	WP 0042-1
NBC Decontamination Procedures	WP 0006-3
Notes	WP 0001-4
NSN Index.....	WP 0042-1
Nuclear Decontamination Procedures	WP 0006-3
O	
Operation of Windows and Doors (Type I Shown)	WP 0005-23
Operation Under Unusual Conditions	WP 0006-1
Operation Under Usual Conditions	WP 0005-1
Operation, Theory of	WP 0003-1
Operator Controls and Indicators, Description and Use of	WP 0004-1
Operator Maintenance, Light Set	WP 0013-1
Operator Maintenance, Tent Fabric Assemblies.....	WP 0012-1
P	
Part Number Index	WP 0043-1
Patch Application, Adhesive	WP 0012-3
Patch Application, Hand Stitched	WP 0012-4
Plain Wall Assembly.....	WP 0002-4
Plain Wall Assembly Repair Parts and Special Tools Lists (RPSTL)	WP 0020-2

Subject

WP Sequence No. – Page No.

P - continued

Plain Wall Liner	WP 0002-11
Plain Wall Liner Repair Parts and Special Tools Lists (RPSTL)	WP 0027-2
PMCS	WP 0010-1
PMCS Introduction	WP 0009-1
PMCS, Fabric Assemblies	WP 0010-4
PMCS, Frame Assembly	WP 0010-2
PMCS, Light Set	WP 0010-7
PMCS, Mapboard	WP 0010-5
PMCS, Table	WP 0010-5
PMCS, Transport Bags	WP 0010-8
Preparation For Shipment	WP 0001-2
Preparation For Storage	WP 0001-2
Prepare MCPS Fabric Sections for Movement (Type I Shown)	WP 0005-29
Prepare Tables and Mapboards for Movement	WP 0005-26
Preparing Frame Sections for Movement	WP 0005-33
Preventative Maintenance Checks and Services (PMCS)	WP 0010-1
Preventative Maintenance Checks and Services Introduction	WP 0009-1
Prevention and Control, Corrosion (CPC)	WP 0001-2
Procedures, Troubleshooting	WP 0008-1
Purlin, Repair	WP 0014-3
Purpose Of Equipment	WP 0001-1

Q

Quality Of Material	WP 0001-4
---------------------------	-----------

R

Rafter Assembly, Repair	WP 0014-3
Rafters, Assemble	WP 0005-3
Rain Gutter Assembly	WP 0002-9
Rain Gutter Assembly Insulated Liner	WP 0002-17
Rain Gutter Assembly Repair Parts and Special Tools Lists (RPSTL)	WP 0025-2
Records	WP 0001-1
References	WP 0044-1
Remarks for Modular Command Post System	WP 0046-4
Remove Light Assembly (P/N 5-4-8194)	WP 0013-1
Repair Handle, Rafter Assembly, Upper Leg Assembly, or Purlin	WP 0014-3
Repair Mapboard Assembly	WP 0015-2
Repair Parts and Special Tools Lists (RPSTL) Introduction	WP 0018-1
Repair Parts For Special Tools	WP 0040-1
Repair Tent Fabric Assemblies with Adhesive Patch Application	WP 0012-3
Repair Tent Fabric Assemblies with Hand Stitched Patch Application	WP 0012-4
Repair Webbing and Buckles	WP 0012-7
Replace a Die-Inserted Grommet	WP 0012-6
Replace Cable Assemblies	WP 0014-6
Replace Detent Assembly	WP 0014-5
Replace Frame Lower Leg Assemblies	WP 0014-4
Replace Light Assembly	WP 0013-4

Subject

WP Sequence No. – Page No.

R - continued

Reporting Equipment Improvement Recommendations (EIR).....	WP 0001-1
Reports.....	WP 0001-1
Roof Cap Assembly	WP 0002-8
Roof Cap Assembly Insulated Liner.....	WP 0002-16
Roof Cap Installation.....	WP 0005-8
Roof Cap, Anchoring.....	WP 0005-11
Roof Cap Assembly Repair Parts and Special Tools Lists (RPSTL)	WP 0024-2
Roof Cap Fabric	WP 0005-30

S

Safety, Care, And Handling.....	WP 0001-4
Salt Air.....	WP 0006-1
Sand Storms	WP 0006-2
Sea Spray.....	WP 0006-1
Secure the Roof Cap Liner.....	WP 0005-7
Service Upon Receipt	WP 0011-1
Set-Up, Entrance Way	WP 0005-18
Setup, Wall Assembly	WP 0005-16
Shipment, Preparation For	WP 0001-2
Snow	WP 0006-2
Special Feature	WP 0001-1
Special Tools, Repair Parts For	WP 0040-1
Staking Tent lines.....	WP 0005-10
Stitch, Chain, Type 401	WP 0017-2
Stitch, Lock, Type 301	WP 0017-2
Stitches, Hand	WP 0012-5
Storage, Preparation For	WP 0001-2
Stove Pipe Flap.....	WP 0005-23
Support Straps	WP 0002-18

T

Table and Mapboard.....	WP 0002-18
Table and Mapboard PMCS.....	WP 0010-5
Table, Field, Folding Legs, Metal Repair Parts and Special Tools Lists (RPSTL)	WP 0034-2
Table, Folding	WP 0005-22
Tables, Prepare for Movement	WP 0005-26
Taut, MCPS Will Not Stay	WP 0008-3
Telescopic Pole Assemblies	WP 0002-2
Tent Fabric Assemblies.....	WP 0002-4
Tent Fabric Assemblies – Direct Support Maintenance.....	WP 0017-1
Tent Fabric Assemblies – Operator Maintenance	WP 0012-1
Tent Frame Assembly	WP 0002-3
Tent Frame Bracket	WP 0002-2
Tent Leaking Troubleshooting (Type I Shown).....	WP 0008-2
Tent Lights Do Not Light	WP 0008-4
Tent lines, Stake	WP 0005-10
Tent Pin Container	WP 0002-20
Tent Pins	WP 0002-2
Tents, Complexing	WP 0005-14

Subject

WP Sequence No. – Page No.

T - continued

Test Equipment	WP 0046-4
Theory of Operation	WP 0003-1
Tools and Test Equipment for Modular Command Post System.....	WP 0046-4
Transport Bag Assembly – Fabric Repair Parts and Special Tools Lists (RPSTL)	WP 0038-2
Transport Bags and Tent Pin Container	WP 0002-20
Transport Bags PMCS	WP 0010-8
Troubleshooting Index.....	WP 0007-1
Troubleshooting Procedures.....	WP 0008-1
Troubleshooting, Frame Assembly	WP 0008-1
Troubleshooting, Tent Leaking	WP 0008-2
Type 301 Lock Stitch.....	WP 0017-2
Type 401 Chain Stitch.....	WP 0017-2
Type I	WP 0002-21
Type III	WP 0002-21
Type Of Manual.....	WP 0001-1

U

Unfolding the Frame Legs.....	WP 0005-9
Unit Maintenance, Frame Assembly	WP 0014-1
Unit Maintenance, Mapboard Assembly	WP 0015-1
Unpack the Three Frame Pieces	WP 0005-2
Unpacking and Inspection.....	WP 0005-2
Unusual Conditions	WP 0006-1
Upper Leg Assembly, Repair	WP 0014-3
Usual Conditions, Operation Under	WP 0005-1

V

V agents	WP 0006-3
Vestibule/Pin Container.....	WP 0039-2
Volume	WP 0002-22

W

Wall Assembly Setup (Type I Shown).....	WP 0005-16
Wall Liner Installation (Type I Shown)	WP 0005-20
Wall Sections, Connecting	WP 0005-17
Wall, Plain	WP 0002-4
Wall, Window	WP 0002-5
Warning Summary	a
Warnings, Cautions, And Notes.....	WP 0001-4
Warranty Information.....	WP 0001-2
Webbing, Repair	WP 0012-7
Weight	WP 0002-22
Window Wall Assembly.....	WP 0002-5
Window Wall Assembly Repair Parts and Special Tools Lists (RPSTL)	WP 0021-2
Window Wall, Horizontal ECU.....	WP 0002-6
Windows, Operation.....	WP 0005-23

By Order of the Secretary of the Army:

PETER J. SCHOOMAKER
General, United States Army
Chief of Staff

Official:

JOYCE E. MORROW
*Administrative Assistant to the
Secretary of the Army*
0607509

DISTRIBUTION: To be distributed in accordance with initial distribution number (IDN) 255081 requirements for TM 10-8340-243-13&P.

These are the instructions for sending an electronic 2028

The following format must be used if submitting an electronic 2028. The subject line must be exactly the same and all fields must be included; however, only the following fields are mandatory: 1, 3, 4, 5, 6, 7, 8, 9, 10, 13, 15, 16, 17, and 27.

From: "Whomever" whomever@avma27.army.mil

To: amssbriml@natick.army.mil

Subject: DA Form 2028

1. **From:** Joe Smith
2. **Unit** home
3. **Address:** 4300 Park
4. **City:** Hometown
5. **St:** MO
6. **Zip:** 77777
7. **Date Sent:** 19-OCT-93
8. **Pub no:** 55-2840-229-23
9. **Pub Title:** TM
10. **Publication Date:** 04-JUL-85
11. **Change Number:** 7
12. **Submitter Rank:** MSG
13. **Submitter FName:** Joe
14. **Submitter MName:** T
15. **Submitter LName:** Smith
16. **Submitter Phone:** 123-123-1234
17. **Problem:** 1
18. **Page:** 2
19. **Paragraph:** 3
20. **Line:** 4
21. **NSN:** 5
22. **Reference:** 6
23. **Figure:** 7
24. **Table:** 8
25. **Item:** 9
26. **Total:** 123
27. **Text:**

This is the text for the problem below line 27.

RECOMMENDED CHANGES TO PUBLICATIONS AND BLANK FORMS For use of this form, see AR 25-30; the proponent agency is ODISC4.						Use Part II (reverse) for Repair Parts and Special Tool Lists (RPSTL) and Supply Catalogs/Supply Manuals (SC/SM).	DATE <i>21 October 2003</i>
TO: (Forward to proponent of publication or form) (Include ZIP Code) COMMANDER U.S. ARMY TANK-AUTOMOTIVE AND ARMAMENT COMMAND ATTN: AMSTA-LC-CECT 15 KANSAS STREET NATICK, MA 01760-5052						FROM: (Activity and location) (Include ZIP Code) <i>PFC Jane Doe</i> <i>CO A 3rd Engineer BR</i> <i>Ft. Leonardwood, MO 63108</i>	
PART I – ALL PUBLICATIONS (EXCEPT RPSTL AND SC/SM) AND BLANK FORMS							
PUBLICATION/FORM NUMBER TM 10-1670-296-23&P				DATE 30 October 2002	TITLE Unit Manual for Ancillary Equipment for Low Velocity Air Drop Systems		
ITEM NO.	PAGE NO.	PARA-GRAPH	LINE NO. *	FIGURE NO.	TABLE NO.	RECOMMENDED CHANGES AND REASON <i>(Provide exact wording of recommended changes, if possible).</i>	
	0036 00-2				1	<i>In table 1, Sewing Machine Code Symbols, the second sewing machine code symbol should be MD ZZ not MD 22.</i> <i>Change the manual to show Sewing Machine, Industrial: Zig-Zag; 308 stitch; medium-duty; NSN 3530-01-181-1421 as a MD ZZ code symbol.</i>	
<small>*Reference to line numbers within the paragraph or subparagraph.</small>							
TYPED NAME, GRADE OR TITLE Jane Doe, PFC				TELEPHONE EXCHANGE/AUTOVON, PLUS EXTENSION 508-233-4141		SIGNATURE Jane Doe <i>Jane Doe</i>	

TO: <i>(Forward direct to addressee listed in publication)</i> COMMANDER U.S. ARMY TANK-AUTOMOTIVE AND ARMAMENT COMMAND ATTN: AMSTA-LC-CECT 15 KANSAS STREET NATICK, MA 01760-5052	FROM: <i>(Activity and location) (Include ZIP Code)</i> <i>PFC Jane Doe</i> <i>CO A 3rd Engineer BR</i> <i>Ft. Leonardwood, MO 63108</i>	DATE 21 October 2003
--	---	--------------------------------

PART II – REPAIR PARTS AND SPECIAL TOOL LISTS AND SUPPLY CATALOGS/SUPPLY MANUALS

PUBLICATION NUMBER TM 10-1670-296-23&P	DATE 30 October 2002	TITLE Unit Manual for Ancillary Equipment for Low Velocity Air Drop Systems
--	--------------------------------	---

PAGE NO.	COLM NO.	LINE NO.	NATIONAL STOCK NUMBER	REFERENCE NO.	FIGURE NO.	ITEM NO.	TOTAL NO. OF MAJOR ITEMS SUPPORTED	RECOMMENDED ACTION
0066 00-1					4			<i>Callout 16 in figure 4 is pointed to a <u>D-Ring</u>. In the Repair Parts List key for figure 4, item 16 is called a <u>Snap Hook</u>. Please correct one or the other.</i>

SAMPLE

PART III – REMARKS *(Any general remarks or recommendations, or suggestions for improvement of publications and blank forms. Additional blank sheets may be used if more space is needed.)*

TYPED NAME, GRADE OR TITLE	TELEPHONE EXCHANGE/AUTOVON, PLUS EXTENSION	SIGNATURE
----------------------------	--	-----------

<p align="center">RECOMMENDED CHANGES TO PUBLICATIONS AND BLANK FORMS</p> <p>For use of this form, see AR 25-30; the proponent agency is ODISC4.</p>						Use Part II (reverse) for Repair Parts and Special Tool Lists (RPSTL) and Supply Catalogs/Supply Manuals (SC/SM).	DATE
TO: (Forward to proponent of publication or form) (Include ZIP Code) COMMANDER U.S. ARMY TANK-AUTOMOTIVE AND ARMAMENT COMMAND ATTN: AMSTA-LC-CECT 15 KANSAS STREET NATICK, MA 01760-5052						FROM: (Activity and location) (Include ZIP Code)	
PART I – ALL PUBLICATIONS (EXCEPT RPSTL AND SC/SM) AND BLANK FORMS							
PUBLICATION/FORM NUMBER TM 10-8340-243-13&P				DATE 30 APRIL 2006	TITLE Modular Command Post System (MCPS), Small		
ITEM NO.	PAGE NO.	PARA-GRAPH	LINE NO. *	FIGURE NO.	TABLE NO.	RECOMMENDED CHANGES AND REASON <i>(Provide exact wording of recommended changes, if possible).</i>	
*Reference to line numbers within the paragraph or subparagraph.							
TYPED NAME, GRADE OR TITLE				TELEPHONE EXCHANGE/AUTOVON, PLUS EXTENSION		SIGNATURE	

TO: <i>(Forward direct to addressee listed in publication)</i> COMMANDER U.S. ARMY TANK-AUTOMOTIVE AND ARMAMENT COMMAND ATTN: AMSTA-LC-CECT 15 KANSAS STREET NATICK, MA 01760-5052	FROM: <i>(Activity and location) (Include ZIP Code)</i>	DATE
--	--	-------------

PART II – REPAIR PARTS AND SPECIAL TOOL LISTS AND SUPPLY CATALOGS/SUPPLY MANUALS

PUBLICATION NUMBER TM 10-8340-243-13&P	DATE 30 APRIL 2006	TITLE Modular Command Post System (MCPS), Small
---	-----------------------	---

PAGE NO.	COLM NO.	LINE NO.	NATIONAL STOCK NUMBER	REFERENCE NO.	FIGURE NO.	ITEM NO.	TOTAL NO. OF MAJOR ITEMS SUPPORTED	RECOMMENDED ACTION

PART III – REMARKS

(Any general remarks or recommendations, or suggestions for improvement of publications and blank forms. Additional blank sheets may be used if more space is needed.)

TYPED NAME, GRADE OR TITLE	TELEPHONE EXCHANGE/AUTOVON, PLUS EXTENSION	SIGNATURE
----------------------------	--	-----------

<p align="center">RECOMMENDED CHANGES TO PUBLICATIONS AND BLANK FORMS</p> <p>For use of this form, see AR 25-30; the proponent agency is ODISC4.</p>						Use Part II (reverse) for Repair Parts and Special Tool Lists (RPSTL) and Supply Catalogs/Supply Manuals (SC/SM).	DATE
TO: (Forward to proponent of publication or form) (Include ZIP Code) COMMANDER U.S. ARMY TANK-AUTOMOTIVE AND ARMAMENT COMMAND ATTN: AMSTA-LC-CECT 15 KANSAS STREET NATICK, MA 01760-5052						FROM: (Activity and location) (Include ZIP Code)	
PART I – ALL PUBLICATIONS (EXCEPT RPSTL AND SC/SM) AND BLANK FORMS							
PUBLICATION/FORM NUMBER TM 10-8340-243-13&P				DATE 30 APRIL 2006	TITLE Modular Command Post System (MCPS), Small		
ITEM NO.	PAGE NO.	PARA-GRAPH	LINE NO. *	FIGURE NO.	TABLE NO.	RECOMMENDED CHANGES AND REASON <i>(Provide exact wording of recommended changes, if possible).</i>	
*Reference to line numbers within the paragraph or subparagraph.							
TYPED NAME, GRADE OR TITLE				TELEPHONE EXCHANGE/AUTOVON, PLUS EXTENSION		SIGNATURE	

TO: (Forward direct to addressee listed in publication) COMMANDER U.S. ARMY TANK-AUTOMOTIVE AND ARMAMENT COMMAND ATTN: AMSTA-LC-CECT 15 KANSAS STREET NATICK, MA 01760-5052	FROM: (Activity and location) (Include ZIP Code)	DATE
---	---	-------------

PART II – REPAIR PARTS AND SPECIAL TOOL LISTS AND SUPPLY CATALOGS/SUPPLY MANUALS

PUBLICATION NUMBER TM 10-8340-243-13&P	DATE 30 APRIL 2006	TITLE Modular Command Post System (MCPS), Small
---	-----------------------	---

PAGE NO.	COLM NO.	LINE NO.	NATIONAL STOCK NUMBER	REFERENCE NO.	FIGURE NO.	ITEM NO.	TOTAL NO. OF MAJOR ITEMS SUPPORTED	RECOMMENDED ACTION

PART III – REMARKS

(Any general remarks or recommendations, or suggestions for improvement of publications and blank forms. Additional blank sheets may be used if more space is needed.)

TYPED NAME, GRADE OR TITLE	TELEPHONE EXCHANGE/AUTOVON, PLUS EXTENSION	SIGNATURE
----------------------------	--	-----------

<p align="center">RECOMMENDED CHANGES TO PUBLICATIONS AND BLANK FORMS</p> <p>For use of this form, see AR 25-30; the proponent agency is ODISC4.</p>						Use Part II (reverse) for Repair Parts and Special Tool Lists (RPSTL) and Supply Catalogs/Supply Manuals (SC/SM).	DATE
TO: (Forward to proponent of publication or form) (Include ZIP Code) COMMANDER U.S. ARMY TANK-AUTOMOTIVE AND ARMAMENT COMMAND ATTN: AMSTA-LC-CECT 15 KANSAS STREET NATICK, MA 01760-5052						FROM: (Activity and location) (Include ZIP Code)	
PART I – ALL PUBLICATIONS (EXCEPT RPSTL AND SC/SM) AND BLANK FORMS							
PUBLICATION/FORM NUMBER TM 10-8340-243-13&P				DATE 30 APRIL 2006	TITLE Modular Command Post System (MCPS), Small		
ITEM NO.	PAGE NO.	PARA-GRAPH	LINE NO. *	FIGURE NO.	TABLE NO.	RECOMMENDED CHANGES AND REASON <i>(Provide exact wording of recommended changes, if possible).</i>	
<i>*Reference to line numbers within the paragraph or subparagraph.</i>							
TYPED NAME, GRADE OR TITLE				TELEPHONE EXCHANGE/AUTOVON, PLUS EXTENSION		SIGNATURE	

TO: (Forward direct to addressee listed in publication) COMMANDER U.S. ARMY TANK-AUTOMOTIVE AND ARMAMENT COMMAND ATTN: AMSTA-LC-CECT 15 KANSAS STREET NATICK, MA 01760-5052	FROM: (Activity and location) (Include ZIP Code)	DATE
---	---	-------------

PART II – REPAIR PARTS AND SPECIAL TOOL LISTS AND SUPPLY CATALOGS/SUPPLY MANUALS

PUBLICATION NUMBER TM 10-8340-243-13&P	DATE 30 APRIL 2006	TITLE Modular Command Post System (MCPS), Small
---	-----------------------	---

PAGE NO.	COLM NO.	LINE NO.	NATIONAL STOCK NUMBER	REFERENCE NO.	FIGURE NO.	ITEM NO.	TOTAL NO. OF MAJOR ITEMS SUPPORTED	RECOMMENDED ACTION

PART III – REMARKS

(Any general remarks or recommendations, or suggestions for improvement of publications and blank forms. Additional blank sheets may be used if more space is needed.)

TYPED NAME, GRADE OR TITLE	TELEPHONE EXCHANGE/AUTOVON, PLUS EXTENSION	SIGNATURE
----------------------------	--	-----------

The Metric System and Equivalents

Linear Measure

1 centimeter = 10 millimeters = .39 inch
 1 decimeter = 10 centimeters = 3.94 inches
 1 meter = 10 decimeters = 39.37 inches
 1 dekameter = 10 meters = 32.8 feet
 1 hectometer = 10 dekameters = 328.08 feet
 1 kilometer = 10 hectometers = 3,280.8 feet

Weights

1 centigram = 10 milligrams = .15 grain
 1 decigram = 10 centigrams = 1.54 grains
 1 gram = 10 decigrams = .035 ounce
 1 dekagram = 10 grams = .35 ounce
 1 hectogram = 10 dekagrams = 3.52 ounces
 1 kilogram = 10 hectograms = 2.2 pounds
 1 quintal = 100 kilograms = 220.46 pounds
 1 metric ton = 10 quintals = 1.1 short tons

Liquid Measure

1 centiliter = 10 milliliters = .34 fl. ounce
 1 deciliter = 10 centiliters = 3.38 fl. ounces
 1 liter = 10 deciliters = 33.81 fl. ounces
 1 dekaliter = 10 liters = 2.64 gallons
 1 hectoliter = 10 dekaliters = 26.42 gallons
 1 kiloliter = 10 hectoliters = 264.18 gallons

Square Measure

1 sq. centimeter = 100 sq. millimeters = .155 sq. inch
 1 sq. decimeter = 100 sq. centimeters = 15.5 sq. inches
 1 sq. meter (centare) = 100 sq. decimeters = 10.76 sq. feet
 1 sq. dekameter (are) = 100 sq. meters = 1,076.4 sq. feet
 1 sq. hectometer (hectare) = 100 sq. dekameters = 2.47 acres
 1 sq. kilometer = 100 sq. hectometers = .386 sq. mile

Cubic Measure

1 cu. centimeter = 1000 cu. millimeters = .06 cu. inch
 1 cu. decimeter = 1000 cu. centimeters = 61.02 cu. inches
 1 cu. meter = 1000 cu. decimeters = 35.31 feet

Approximate Conversion Factors

<i>To change</i>	<i>To</i>	<i>Multiply by</i>	<i>To change</i>	<i>To</i>	<i>Multiply by</i>
inches	centimeters	2.540	ounce-inches	newton-meters	.007062
feet	meters	.305	centimeters	inches	.394
yards	meters	.914	meters	feet	3.280
miles	kilometers	1.609	meters	yards	1.094
square inches	square centimeters	6.451	kilometers	miles	.621
square feet	square meters	.093	square centimeters	square inches	.155
square yards	square meters	.836	square meters	square feet	10.764
square miles	square kilometers	2.590	square meters	square yards	1.196
acres	square hectometers	.405	square kilometers	square miles	.386
cubic feet	cubic meters	.028	square hectometers	acres	2.471
cubic yards	cubic meters	.765	cubic meters	cubic feet	35.315
fluid ounces	milliliters	29.573	cubic meters	cubic yards	1.308
pints	liters	.473	milliliters	fluid ounces	.034
quarts	liters	.946	liters	pints	2.113
gallons	liters	3.785	liters	quarts	1.057
ounces	grams	28.349	liters	gallons	.264
pounds	kilograms	.454	grams	ounces	.035
short tons	metric tons	.907	kilograms	pounds	2.205
pound-feet	newton-meters	1.356	metric tons	short tons	1.102
pound-inches	newton-meters	.11296			

Temperature (Exact)

$\frac{5}{9}$ (after subtracting 32) Celsius temperature

PIN: 083050-000